

# NATIONAL BUILDING CODE



**for VANUATU**

**NATIONAL BUILDING  
CODE**

**VANUATU**

---

## CONTENTS

### PREFACE

### ACKNOWLEDGEMENT

### INTRODUCTION

#### A GENERAL PROVISIONS

- A1 Interpretation
- A2 Acceptance of Design and Construction
- A3 Classification of Buildings and Structures
- A4 United Buildings

#### B STRUCTURE

##### Performance Requirements Deemed-to-Satisfy Provision

- B1 Structural Provisions
- B2 Demolition

### DWELLINGS AND OUTBUILDINGS

#### DC FIRE RESISTANCE

##### Performance Requirements Deemed-to-Satisfy Provisions

- DC1 Fire Resistance and Stability

#### DD ACCESS AND EGRESS

##### Performance Requirements Deemed-to-Satisfy Provisions

- DD1 Construction of Exits

#### DE ELECTRICITY

##### Performance Requirements Deemed-to-Satisfy Provisions

- DE1 Electricity Safety
- DE2 Amenity

#### DF HEALTH AND AMENITY

##### Performance Requirements Deemed-to-Satisfy Provisions

- DF1 Damp and Weatherproofing
- DF2 Cooking and Sanitary Facilities
- DF3 Room Sizes and Heights
- DF4 Light and Ventilation
- DF5 Watersupply Plumbing
- DF6 Sanitary Plumbing and Drainage
- DF7 Roof Drainage

- NG2 Fireplaces, Chimneys and Flues
- NG3 Atrium Construction

#### DG ANCILLARY PROVISIONS

##### Performance Requirements Deemed-to-Satisfy Provision

- DG1 Minor Structural and Components
- DG2 Fireplaces, Chimneys and Flues

### PUBLIC BUILDINGS AND GROUP DWELLINGS

#### NC FIRE RESISTANCE

##### Performance Requirements Deemed-to-Satisfy Provision

- NC1 - Fire Resistance and Stability
- NC2 - Compartmentation and Separation
- NC3 - Protection of Openings

#### ND ACCESS AND EGRESS

##### Performance Requirements Deemed-to-Satisfy Provision

- ND1 Provision of Escape
- ND2 Construction of Exits
- ND3 Access for People with Disabilities

#### NE SERVICES AND EQUIPMENT

##### Performance Requirements Deemed-to-Satisfy Provision

- NE1 Fire Fighting Equipment
- NE2 Mechanical Ventilation
- NE3 Lift Installations
- NE4 Emergency Lighting and Exit Signs
- NE5 Maintenance of Safety Installations
- NE6 Electricity

#### NF HEALTH AND AMENITY

##### Performance Requirements Deemed-to-Satisfy Provision

- NF1 Damp and Weatherproofing
- NF2 Sanitary Facilities
- NF3 Room Sizes
- NF4 Light and Ventilation
- NF5 Watersupply Plumbing
- NF6 Sanitary Plumbing and Drainage
- NF7 Roof Drainage

#### NG ANCILLARY PROVISIONS

##### Performance Requirements Deemed-to-Satisfy Provision

- NG1 Minor Structures and Components

#### NH SPECIAL USE BUILDINGS

---

**Performance Requirements  
Deemed-to-Satisfy Provision**

NH1 Theatres, Stages and Public Halls

---

---

## PREFACE 2000 EDITION

As anticipated in the original edition The National Building Code of Vanuatu has been revised to ensure its currency and relevance. The two primary areas of revision are:

1. International Standards have been reviewed to ensure only current standards are referenced.
2. The recommendations arising from the Sanitation Master Plan for Port Vila have been incorporated into the document.

## PREFACE 1990 EDITION

The work on the National Building Code was begun in response to the significant threat of death and destruction that cyclones pose for Vanuatu every summer. The Government of Vanuatu readily agreed to participate in the Project. A broad based Building advisory Committee was formed to work with the Project Office.

The composition of the Committee bears ample testimony to the public support that it has had for its work. The members represented a wide range of interest and all of them worked on a voluntary basis. Builders, Architects, Engineers, the Fire Service, Insurers, the Central and Local Government Departments and the National Housing Corporation were all among the organisations which had representative working on the Committee. The principal aim of the Project was to incorporate in the Code appropriate preventive measures which will help to resist the harmful effects of cyclones, earthquakes, fires and other such natural hazards and forces. While achieving this aim it was also necessary to ensure that the provisions of the Code were within the economic and technical means of the country.

The Australian Government had established the Project in March 1988. Since then the Project office has works very closely with the Committee on a participatory basis. Beginning with a draft based on the Building Code of Australia several revised drafts of the Code were produced. Each successive draft gained significantly from the critical comments and suggestions from the members of the Committee. Several overseas experts freely gave their time to help with crucial advice on specific aspects of the Code. Explanatory sessions were held with the Committee members to elicit critical opinions on the provisions of the Code and thus shape the Code to be technically and economically relevant for use in Vanuatu.

The actual use of the Code will in course of time reveal particular areas where it might need some modification. In fact it is only such periodic examination and suitable revision which will keep it up-to-date and relevant. In the meantime the extensive participation of the members of the Committee in the work on the Code has ensured that in a very real sense it is the National Building Code of Vanuatu.

Kris Ayyar  
Project Manager  
Pacific Building Standards Project

Suva : September 1990

---

## ACKNOWLEDGEMENT 2000 EDITION

The update of the National Building Code was made possible through the provision of funding by the Asian Development Bank under technical assistance #2596. Their support to provide Vanuatu with a relevant up to date Building Code is acknowledged gratefully.

## ACKNOWLEDGEMENT 1990 EDITION

A very large number of people and the organisations that they represent have contributed to the successful completion of the Code. It is not possible to acknowledge their help individually. Among those who were especially generous were:-

### IN VANUATU

George Pakoa, First Secretary, Ministry of Finance and Housing, and the Chairman of the Building Advisory Committee. He exercised a sobering influence on our work and helped to retain the needs of Vanuatu in our perspective.

David Blaikie, Physical Planning Advisor and the Secretary of the Committee worked very hard in collecting relevant information, organising all the Committee meetings and with other administrative tasks. His knowledge and experience as a Planner was very useful and he helped to bring to the attention of the members the more contentious provisions in the drafts which needed to be discussed thoroughly.

Peter Morris, Planning Officer, Port Vila Municipal Council provided detailed knowledge on current building control practices and contributed to the preparation of the Code.

Tony Lee, Principal Design Engineer and Martin Quaile, Chief architect, Public Works Department gave excellent technical support with their background knowledge of building Practices in Vanuatu.

André Francois, Managing Director, SELB Pacific influenced the work on the Code with his detailed knowledge as a very experienced Building Contractor in Vanuatu.

Geoffrey Feast, Resident Partner of James Ferrie & Partners took a very active interest in the preparation of the Code. His detailed knowledge of architectural practices in Vanuatu was of very great help.

Wreath Bule, General Manager, National Housing Corporation and his officers Peter Fagan, Engineer, Toby Tobias, Senior Technical Officer, and Mark Bozier, Technical Officer, were very helpful in exercising a necessary balance to the Code by focusing on housing for those on low income. Peter was particularly forceful in championing the cause of the very poor.

Richard Prevot, Seismologist currently at Cornell University and earlier with the Office de la Recherche Scientifique et Technique Outré-Mar (ORSTOM) gave valuable advice about seismicity in Vanuatu.

Abie Jack, Officer-in-Charge of the Vanuatu Fire Service and John Henry Sils, Officer-in-Charge of the Santo Fire Station, helped with their detailed knowledge of fire prevention in Vanuatu.

Bruce Bowers and Bob Urry the past and current General Managers of QBE Insurance (Vanuatu) Limited actively promoted the need for appropriate levels of building control in Vanuatu.

Ray Saunders and Paul Taylor, Structural Engineers with Cameron McNamara promoted the cause of a relatively simple-to-use- Code.

### IN FIJI

Roderick Moody, Consulting Engineer gave valuable help with his advice on building services.

Trevor Jones, Senior Seismologist of the Government of Fiji was very helpful with his advice on the provision of different levels of earthquake risk. He also volunteered for the painstaking job of proof reading and did an excellent job.

---

Stefan Ali of Datacom gave excellent support service to our computer system.

Davendra Rao, Education Officer (retired) performed the onerous task of proof reading.

Robert Austin, Printing and Design Consultant gave us professional advice on the cover design and printing of the Code.

## **IN AUSTRALIA**

Robert Hogg, Director, Australian Uniform Building Regulations Co-ordinating Council and the members of its Executive Committee showed their great generosity in exempting us from the copyright requirements of the Building Code of Australia.

Dr George Walker, formerly Associate Professor of Civil Engineering at the James Cook University and currently Director National Building Technology Centre, Sydney was of immense help.

Stewart Horwood, Chief Executive, Peter Walsh, Director Standards and other officers of the Standards Association of Australia were very helpful with the supply of Australian Standards and relevant explanations. I have reproduced five diagrams from Australian Standard AS 2180 in Specification NF7.2 of the Code.

Geoff Anderson, Associate Director, and Hugh Knox, Manager Regulations Accreditations and Standards of the National Building Technology Centre helped with the supply of references and technical advice.

Lawrence Reddaway, Director Irwin Johnston & Partners Melbourne and Dr Vaughan Beck Principal Lecturer Footscray Institute of Technology gave invaluable advice on fire engineering that gave me ideas for cost-reducing changes without any material reduction in life-safety.

Jane Blackmore, Consulting Engineer Sydney made an overall review of the draft Code and gave her comments.

Paul Smith, Assistant Director, Leo Blumkie Manager Building Services and Ron de Veer, Referee of the Queensland Department of Local Government helped with their comments and explanations of building control practices in Queensland.

## **IN NEW ZEALAND**

John Hunt, Executive Director, and Boyd Dunlop, Executive Officer of the Building Industry Commission. They have provided valuable advice and kept us informed of their work on the production of the New Zealand Building Code. I have borrowed ideas and concepts from their work and reproduced with suitable alternations two diagrams and their acceptable solution for stairways and ramps in the Code.

Russell Cooney, Manager Building Industry Development, and Andrew King, Leader Structural Engineering Group of the Building Research Association of New Zealand. Russell and Andrew gave willingly of their time and expertise especially in the area of designing against earthquake and safety against human impact of glass. They also supplied us with valuable reference documents.

Denys Pinfold and Denis Ferrier, the past and present Directors and other officers of the Standards Association of New Zealand, helped with the supply of New Zealand Standards and useful explanations.

John Fraser, Manager, Fire Protection Inspection Services Limited, Auckland, provided outstanding help with a review of the fire protection provision of the Code and gave us practical advice.

Clifford Barnett, Fire Engineer and Director of McDonald Barnett Prarners Limited, Auckland, and Denis Bastings, Director Fire Safety Advisers Limited, Wellington, gave their time and expertise in discussing the Code requirements.

---

## **IN THE UNITED STATES OF AMERICA**

James Bihl, President International Conference of Building Officials, supplied us with their Uniform Building Code and other related documents which were very useful references.

The Council of American Building Officials: I have reproduced four diagrams after suitable alterations from their publication One and Two Family Dwelling Code in Section DF of the Code.

Elliot Stephenson, Structural and Fire Protection Engineer, spent considerable time with me during his holiday in Fiji and gave valuable advice on the Code.

## **AUSTRALIAN INTERNATIONAL DEVELOPMENT ASSISTANCE BUREAU**

Ed Peek, Secretary Development Assistance at the Australian High Commission at Port Vila and his staff, in particular Victoria Hillman, were very helpful in making the required administrative arrangements in Vanuatu.

Roger Dickson, Engineer with the Pacific Regional Team Sydney, was extremely helpful and acted as a bridge between me and the AIDAB administration.

Mark Latham and Graham Nicholls, past and present Development Aid Counsellors at the Australian Embassy, Suva have supported the work with all the resources at their command.

Cathy Bennett, Keith Joyce and Greg Brooke in Suva, and Arthur Burch, Lynn Pieper and Chris Wheeler in Canberra were all extremely helpful in sorting out the administrative tangles that enveloped the project from time to time. Keith and Greg in particular were associated with the project during its stormiest days and helped to steer it through the reef.

Last but not least were the team in the project office. No words can express my gratitude for their sincerity and dedication. Most directly associated with the specific work on the Code were Saras Prasad for the bulk of the time and Sashi Lata Pal all of the time. In particular I owe Sashi a great deal for her excellent contribution. Wati Ledua, Raveena Dutt and Michael Arun Shankar helped with the many administrative tasks in the office, in particular the production of hundreds of bound copies of the several draft documents. Rohit Singh, Deputy Project Manager and Hem Rao, Project Engineer, were my sounding board for testing the practicality of many of the Code provisions.

Kris Ayyar



---

## INTRODUCTION

### About this Code

The basic objective of the Code is to ensure that acceptable standards of structural sufficiency, fire safety, health and amenity, are maintained for the benefit of the community now and in the future.

The requirements included in this Code are intended to extend no further than is necessary in the public interest, to be cost effective, not needlessly onerous in their application, and easily understood.

### What is in the Code?

The Code sets down the Performance Requirements and corresponding Deemed-to-Satisfy Provisions which apply to the construction of buildings for all classes of occupancy.

It must be recognized that a building code cannot cover every issue concerned with the design and construction of buildings. In the case of innovative, complex or unusually hazardous building proposals, or other building work beyond the scope of the Code, legislation may provide for the other suitable action.

Where appropriate the Code allows for variations in climate and geological conditions.

The Code covers those aspects of building which are controlled by Approval Authorities such as structure, fire resistance, access and egress, fire-fighting equipment, mechanical ventilation, lift installations, and certain aspects of health and amenity.

### Performance Requirements

These are described in terms which would allow considerable scope for innovation and the development of new materials and methods of construction. The Requirements are in some cases separated into objectives and the required performance.

**Objectives** are broad statements of intent and are included at the beginning of each Section to identify the objectives that the provisions of the Section are intended to achieve. They are the basic concepts which apply generally to all buildings and structures.

**Required Performance** gives the fundamental requirement which will satisfy the objectives and are expressed in performance terms. Accreditation certificates, test report, detailed calculations and other documentary evidence may be used as evidence that a particular material, design or construction method meets the performance requirement of this Code.

### Deemed-to-satisfy Provisions

The Deemed-to-Satisfy Provision have been drafted in sufficiently general terms to allow some flexibility without increasing the need to use administrative discretion. In the absence of national Standards for design, construction and materials, the Standards produced by the Standards Association of Australia and New Zealand have been called up. Detailed specifications have been given where necessary.

### Professional Certification

The Code allows for certificates from professional consultants to be used as evidence of compliance with particular requirement or standards.

The enabling legislation will determine the extent of the use of professional certification and the procedures for the submission of certificates, reports or other documentation to Approval Authorities as evidence of compliance.

### Layout of the Code

The cumbering of Sections and Parts have been made on an alpha-numeric system for ease of reference. It provides flexibility to accommodate future additions or deletions and the future consolidation of building regulations presently contained in other legislation, without undue disruption to the layout.

Other than for common provisions contained in Sections A and B, the Code is divided into two areas – one which covers Class 1 and 10 buildings, and the other which covers all other Classes of buildings.

The pages containing the Performance Requirements are identified by the use of coloured paper. The specifications relating to the Deemed-to-Satisfy provisions have also been printed on coloured paper but with the edges screened.

### Administrative Arrangement

This Code is brought into effect by enabling building control legislation which prescribes or calls up the technical requirements which have to be satisfied in order to gain approval.

The enabling legislation consists of an Act of Parliament and subordinate legislation. It empowers the Administration to regulate certain aspects of the building process and contains the necessary administrative provisions for the works of the Approval Authority. The legislation also imposes responsibilities on the authorities or other persons or bodies, and describes particular administrative procedures.

The Following administrative matters are covered in the enabling or subordinate legislation-

- 
- Plan submission and approval procedures.
  - Issue of building permits.
  - Inspections during and after construction
  - Provision of evidentiary certificates.
  - Issue of certificates of occupancy or compliance.
  - Accreditation or approval of materials or components.
  - Review and enforcement of standards.
  - Fees and charges.

### **Administrative discretion**

The Code is drafted with the object of reducing the need for the Approval Authority to make discretionary decisions.

However, in many cases it is not possible to draft a provision in purely technical terms and an informed judgment is required on the standard which would be suitable in particular circumstances.

Accordingly, in a number of clauses, the Code requires a particular material or construction method to be "suitable", meaning fit in all relevant respects for its intended purpose and use.

The Approval Authority responsible for the enforcement of building controls retains the right to Question "suitability" and difference of opinion are open to appeal.

---

**ALL BUILDINGS**

SECTION **A**

---

**GENERAL PROVISIONS**

A1	Interpretation
A2	Acceptance of Design and Construction
A3	Classification of Buildings and Structures
A4	United Buildings

---

# **SECTION A**

THIS SECTION APPLIES TO ALL BUILDINGS

---

## CONTENTS

Part		Part	
<b>A1</b>	<b>Interpretation</b>	<b>A3</b>	<b>Classification of Buildings and Structures</b>
A1.1	Definitions	A3.1	Principles of classification
A1.2.2	Adoption of Standards and other references	A3.2	Classifications
A1.3	Referenced Standards. etc	A3.3	Multiple classification
A1.4	Differences between referenced documents and this code	<b>A4</b>	<b>United Buildings</b>
A1.5	Mandatory provisions	A4.1	When buildings are united
<b>A2</b>	<b>Acceptance of Design and Construction</b>	A4.2	Alterations in a united building
A2.1	Suitability of materials	<b>Specification</b>	
A2.2	Evidence of suitability	Specification A1.3	Standards Adopted by Reference
A2.3	Fire-resistance of building elements	Specification A2.3	Fire-Resistance of Building Elements
A2.4	Early Fire Hazard Indices	Specification A2.4	Early Fire Hazard Test for Assemblies

---

---

## INTERPRETATION

### A1.1 Definitions

Some of the words and phrases used in the Code have specific defined meanings. Wherever such meaning is intended the words and phrases are printed in italics. The defined meanings are:

**Alteration**, in relation to a building, includes an addition or extension to a building.

#### Approved Person –

- (a) Professional civil engineer qualified with a degree in civil engineering from the:
  - (i) PNG University of Technology (Unitech), Lae, PNG and or;
  - (ii) A university in Australia or New Zealand recognized by the respective engineering institutions in Australia or New Zealand (IEA, IPENZ) and or;
- (b) Technician engineering with:
  - (i) a recognised civil engineering technicians qualification from the Fiji Institution of Technology (FIT) and or;
  - (ii) an NZCE qualification and or;
  - (iii) an approved engineering technicians qualification from Australia.
- (c) Professional civil engineering consultant registered and approved to practise in Vanuatu.

**Assembly building** a building where people may assemble for –

- (a) civic, theatrical, social, political or religious purposes;
- (b) educational purposes in a school, *early childhood centre*, preschool, or the like;
- (c) entertainment, recreational or sporting purposes; or
- (d) transit purposes.

**Atrium** a space within a building that connects 2 or more *storeys*, and –

- (a) is wholly or substantially enclosed at the top by a floor or roof (including a glazed roof structure); and
- (b) includes any adjacent part of the building not separated by bounding construction; but
- (c) does not include a stairwell, rampwell or the space within a *shaft*.

**Automatic** applied to a fire door, smoke door, fire shutter, smoke and-heat vent, *sprinkler system*, alarm system or the like, means designed to operate when activated by a heat, smoke or fire sensing device.

**Backstage** a space associated with, and adjacent to, a *stage* in a Class 9b building for scenery, props, equipment, dressing rooms, or the like.

**Certificate of Accreditation** a certificate acceptable to the Approval Authority stating that the properties and performance of a building material or method of construction or design fulfil specific requirements of this Code.

**Charged Dry Riser Main System** one or more *riser mains* in a building complete with all *required* fittings, not permanently connected to a *fire main*. Instead of leaving the system dry, it is charged with water from any convenient domestic supply in order to make it self-monitoring against inadvertently left open *hydrant* valves and leakage.

#### Combustible –

- (a) applied to a material – means *combustible* under AS1530.1
- (b) applied to construction or part of a building – means constructed wholly or in part of *combustible* materials.

(See definition of *non-combustible*)

**Common Wall** a wall that is common to adjoining buildings.

**Curtain Wall** a *non-loadbearing external wall* that is not a *panel wall*.

**Drain** a line of pipes to carry *sewage* or *trade waste*, located within the property boundary, laid above or below ground, and includes all fittings and equipment such as inspection openings, traps and gullies.

It is a branch *drain* if it is intended to receive the discharge from fixture discharge pipes. Branch *drains* join a main *drain*.

---

The main *drain* collects the *waste water* from branch *drains* and/or from fixture discharge pipes and conveys them to the *sewer*.

**Early Childhood Centre** a preschool, kindergarten or child-minding centre.

**Effective height** the height to the floor of the topmost *storey* (excluding the topmost *storey* if it contains only heating, ventilating, lift or other equipment, water tanks or similar service units) from the floor or open *space*. The road or open *space* must be capable of providing unobstructed access to emergency vehicles.

The *effective height* of a stepped or terraced building is the maximum *effective height* of any segment of the building.

**Exit:**

- (a) Any, or any combination of the following if they provide egress to a road or *open space*:
  - (i) An internal or external stairway.
  - (ii) A ramp complying with Section ND.
  - (iii) A *fire-isolated passageway*.
  - (iv) A doorway opening to a road or *open space*.
- (b) A *horizontal exit* or a *fire-isolated passageway* leading to a *horizontal exit*

**External Wall** an outer wall of a building which is not a *common wall*.

**Fire Brigade Booster Connection** a connecting device enabling the fire brigade to pressurize or pump water into a *riser main* or other systems.

**Fire Compartment** a part of a building which is separated from the remainder in accordance with this Code to resist the spread of fire and smoke.

**Fire-isolated Passageway** a corridor, hallway or the like, of *fire-resisting* construction, which provides egress to or from a *fire-isolated stairway* or *fire-isolated ramp* to a road or *open space*.

**Fire-isolated Ramp** a ramp within a *fire-resisting* enclosure which provides egress from a *storey*

**Fire-isolated Stairway** a stairway within a *fire-resisting shaft* and includes the floor and roof or top enclosing structure.

**Fire Main** a water supply service pipe located outside a building to supply water at adequate pressures and

rates of flow for fire fighting purposes. The *fire main* must be-

- (a) part of a public supply system kept permanently charged with water; or
- (b) privately provided in which case it must either be permanently charge with water from a reliable supply or be provided with adequate on *site* storage and fire pumps.

**Fire-protective Covering** inert material applied in such a manner that it protects other materials or building elements from the damaging effects of fire. Acceptable materials are: -

- (a) 13 mm fire-protective grade plasterboard;
- (b) 12 mm cellulose fibre reinforced sheeting;
- (c) 12 mm mesh-reinforced fibrous plaster in which the mesh is 13 mm x 13 mm x 0.7 mm welded wire located not more than 6 mm from the exposed face; or
- (d) other material not less fire-protective than 13 mm fire-protective grade plasterboard,

fixed in accordance with the normal trade practice for a *fire-protective covering*.

**Fire-resistance Level (FRL)** the grading periods in minutes determined in accordance with Specification A2.3, for –

- (a) *structural adequacy*;
- (b) *integrity*; and
- (c) *insulation*,

and expressed in that order.

**Fire-resisting**, applied to a *structural member* or other part of a building, means having the FRL *required* for that *structural member* or other part.

**Fire-resisting Construction** one of the Types of construction referred to in Part NC1

**Fire-separated Section** a part of a building which is separated from the remainder by *fire walls* in accordance with Part NC2 and thereby regarded as a separate building.

**Fire-source Feature –**

- (a) the far boundary of a road adjoining the allotment;
- (b) a side or rear boundary of the allotment; or

- 
- (c) an *external wall* of another building on the allotment which is not of Class 10.

**Fire Wall** a wall that divides a *storey* or building to resist the spread of fire and smoke and has the FRL *required* under Specification NC1.1.

**Fixture Unit** a unit of measure based on the rate of discharge, time of operation and frequency and use of a sanitary fixture, that denotes the hydraulic load contributed by that fixture to the sanitary plumbing system.

**Flammability Index** the index number determined under AS1530.2.

**Floor Area –**

- (a) in relation to a *storey* – the area of the *storey* measured over the enclosing walls (if any) and that part of any *common wall* located within the allotment; and
- (b) in relation to a room – the area of the room measured within the finished surfaces of the walls, and includes the area occupied by any cupboard or other built-in furniture, fixture or fitting.

**Habitable Room** a room used for normal domestic activities, and –

- (a) includes a bedroom, living room, lounge room, music room, television room, kitchen, dining room, sewing room, study, playroom, family room and sunroom; but
- (b) excludes a bathroom, laundry, water closet, pantry, walk-in wardrobe, corridor, hallway, lobby, photographic darkroom, clothes-drying room, and other spaces of a specialised nature occupied neither frequently nor for extended periods.

**Health-care Building**

- (a) a nursing home, hospital, convalescent home, infirmary or similar institution or home for sick or disabled persons needing full-time nursing care; or
- (b) a clinic or day surgery unit where –
- (i) prescribed surgical procedures are performed on people who do not require overnight care as in-patients in a hospital; and
- (ii) the surgical procedures include a potential requirement for general anaesthesia, major regional anaesthesia or intravenous sedation.

**Horizontal Exit** a *required* doorway through a *required fire wall* separating two portions of a building with approximately the same floor level so as to establish an area of refuge affording safety from fire and/or smoke in the portion from which the escape is made.

**Hydrant** a fire service outlet fitting installed in a *riser main* or a *fire main* which provides a valved outlet to permit a controlled supply of water to be taken from the main for fire fighting. *Hydrants* installed in a *riser main* system within a building are referred to as internal *hydrants* and those installed in a *fire main* outside a building, as external *hydrants*.

**Insulation**, in relation to a FRL, means the ability to maintain a temperature on the surface not exposed to the furnace below the limits specified in AS 1530.4

**Integrity**, in relation to a FRL, means the ability to resist the passage of flames and hot gases specified in AS 1530.4.

**Internal Wall** excludes a *common wall* or a party wall.

**Junction** a sanitary fitting used to connect one or more branch pipes or channels to a main pipe or channel.

A square *junction* connects the main pipe at right angles and has an airtight removable cap to facilitate inspection and cleaning.

An inspection branch is a *junction* with an airtight removable cap to facilitate inspection and cleaning.

**Lightweight Construction** see Specification NC1.5.

**Loadbearing** intended to resist force and moments additional to those due to its own weight.

**Marine and River Protection Zone (MPRZ)** Zone located within 50 metres of marine or river environment.

**Mezzanine Floor** an intermediate floor within a room which is not more than 1/3 of the floor area of the room or 200 m<sup>2</sup>, whichever is the lesser.

**Non-combustible –**

- (a) applied to a material – means not *combustible* except that the material may have a *combustible* surface finish if the finish is not more than 1 mm thick and the *Spread-of-Flame Index* of the assemblage is 0;
- (b) applied to construction or part of a building – means constructed of *non-combustible* material on all exposed faces.



---

The following materials though *combustible* or containing *combustible* materials are required:-

- (i) plasterboard
- (ii) perforated gypsum lath with a normal paper finish
- (iii) fibrous plaster sheet conforming to AS 2185
- (iv) cellulose fibre cement sheeting
- (v) any other material not less fire-protective than any of the materials from (i) to (iv)

**Open-deck Carpark** a carpark in which all parts of the parking *storeys* are cross-ventilated by permanent unobstructed openings in not fewer than 2 opposite or approximately opposite sides, and-

- (a) where each side that provides ventilation is not less than 1/6 of the area of any other side; and
- (b) the openings are not less than ½ of the wall area of the side concerned.

**Open Garage** a carport or garage with 2 or more sides substantially open.

**Open Space** a space on an allotment, or a roof or similar part of a building complying with ND2.12, open to the sky and connected directly with a public road.

**Open Spectator Stand** a tiered stand substantially open at the front.

**Panel wall** a *non-loadbearing external wall*, in frame or similar construction, that is wholly supported at each *storey*.

**Pitch** the maximum angle to the horizontal of a line connecting the nosings of stair treads in a single straight flight of a stairway.

**Private Garage –**

- (a) any garage of a Class 1 building; or
- (b) any single storey of a building of another Class capable of accommodating not more than 3 vehicles, if there is only one such *storey* in the building.

**Professional Consultant** a person with appropriate experience in the relevant field, being –

- (a) if legislation so requires – a registered *professional consultant* in the relevant discipline; or
- (b) a Corporate Member of a recognized professional institution.

**Public Corridor** an enclosed corridor, hallway or the like which –

- (a) serves as a means of egress from 2 or more *sole-occupancy units* to a *required exit* from the *storey* concerned; or
- (b) is *required* to be provided as a means of egress from any portion of a *storey* to a *required exit*.

**Public Carpark** a building that is used for the parking of motor vehicles but is neither a *private garage* nor used for the servicing of vehicles, other than washing, cleaning or polishing.

**Qualified Person:** Building Inspector or Environmental Health inspector of a Municipality or Provincial Government.

**Registered Testing Authority –**

- (a) National Building Technology Centre  
P O Box 30  
CHATSWOOD NSW 2067  
**AUSTRALIA:**
- (b) Council of Scientific and Industrial Research Organisation; Division of Building Research  
P O Box 56  
HIGHETT VIC 3190  
**AUSTRALIA**
- (c) An organisation registered by the National Association of testing Authorities (NATA) to test in the relevant field;
- (d) Building Research Association of New Zealand  
Private Bag  
PORIRUA  
**NEW ZEALAND;**
- (e) Testing laboratories registered by the Testing Laboratory Registration Council (TELARC) OR New Zealand to test in the relevant field;
- (f) An organisation recognized by NATA or TELARC through a mutual recognition agreement;
- (g) Fire Insurers Research and Testing Organisation  
Melrose Avenue  
BOREHAMWOOD  
**LONDON (UK);**
- (h) National Institute of Standards and Technology  
GAITHERSBURG, MD 20899  
**USA;**
- (i) Underwriters Laboratories Incorporated  
333 Pfingsten Road  
NORTHBROOK, IL 60062  
**USA;** or

- 
- (j) National Research Council  
Division of Building Research  
75 Boul De Mortagne  
Boucherville  
QUEBEC  
CANADA

**Repairs** action taken to restore the structural strength or appearance of a building without making any addition or extension to it.

**Required** by this Code.

**Resistance to the incipient spread of Fire** in relation to a ceiling membrane, means the ability of a ceiling membrane to insulate the space between the ceiling and roof, or ceiling and floor above, to limit the temperature rise of *combustibles* in this space during the Standard *Fire Test* to 180°C.

**Rise**, in storeys, means the greatest number of storeys calculated in accordance with NC1.2 at any part of the *external walls* of the building –

- (a) above the finished ground next to that part; or
- (b) if part of the *external wall* is on the boundary of the allotment, above the natural ground level at the relevant part of the boundary.

**Riser Main** a pipe to convey water for fire brigade use to all floors of a building and where appropriate to the roof. A *riser main/system* must consist of either a *wet riser main system* or a *charge dry riser main system*.

**Sanitary Compartment** a room or space containing a toilet fixture, closet pan, soil pan, chemical toilet, or the like.

**Sarking-type Material** a material such as a reflective foil or other flexible membrane of a type normally used for a purpose such as water-proofing, vapour proofing or thermal reflectance.

**School** includes a primary or secondary *school*, college, university or similar educational establishment.

**Self-closing**, applied to a door or *window* means equipped with a device which returns the door or *window* to the fully closed and latched position immediately after each manual opening.

**Service Station** a garage which is not a *private garage* and is for the servicing of vehicles, other than only washing, cleaning or polishing.

**Sewage** waterborne human waste from domestic and commercial premises including faeces and urine, and

waste room kitchens, showers, baths, domestic laundries etc.

**Sewer** a conduit vested in a public authority and located outside the property boundary. It is used for the conveyance of *waste water*.

**Shaft** the walls and other parts of a building bounding –

- (a) a well, other than an *atrium well*; or
- (b) a vertical chute, duct or similar passage, but not a chimney or flue.

**Site** the part of the allotment of land on which a building stands or is to be erected.

**Smoke-and-heat Vent** a vent, located in or near the roof for smoke and hot gases to escape if there is a fire in the building.

**Smoke-Developed Index** the index number for smoke developed under AS 1530.3

**Soil Fixture** a water closet pan, urinal, sanitary napkin disposal unit, slop hopper, bed pan washer or autopsy table.

**Soil Pipe** a pipe which conveys discharge *from Soil Fixtures*.

**Sole-occupancy Unit** a room or other portion of a building for occupation by one owner, lessee, tenant, or other occupier to the exclusion of any other owner, lessee, tenant, or other occupier.

**Spread-of-flame index** the index number for spread of flame under AS 1530.3.

**Sprinkler System** a system of *automatic* fire sprinklers complying with NE1.5.

**Stack** a vertical *drain* including offsets and extending to more than one storey.

**Stage** a floor or platform in Class 9b building on which performances are presented before an audience.

**Standard Fire Test** the Fire-resistance Test of Structures under AS 1530.4

**Storey** a space within a building which is situated between one floor level and the floor level next above, or is there is no floor above, the ceiling or roof above, but not –

- (a) a space that contains only –
  - (i) a lift *shaft*, stairway or meter room;

(ii) a bathroom, shower room, water closet, or other *sanitary compartment*; or

(iii) 3 vehicles or less; or

(iv) a combination of the above; or

(b) a *mezzanine floor*.

**Structural Adequacy**, in relation to a FRL means the ability to maintain stability and adequate *loadbearing* capacity under AS 1530.4.

**Structural member** a component or part of an assembly which provides vertical or lateral support to a building or structure.

**Sweep junction** a long radius bend entering a main pipe at 45° or a 45° junction fitted with a 45° bend.

**Swimming Pool** any excavation or structure containing water and used for swimming, wading, paddling, or the like, including a bathing or wading pool, or spa.

**Trade waste** waterborne waste from business, trade or manufacturing process containing predominantly non-human waste, but not unpolluted water.

**Ward area** that portion of a *storey* of a class 9a building for residing patients and includes areas for sleeping, recreation and sanitary facilities, and nurses stations.

**Waste Fixture** a sanitary fixture other than a *soil fixture*. Examples are: basins. Bidets. Kitchen sink. Laundry trough etc.

**Waste pipe** a pipe which conveys the discharge from *waste fixtures*.

**Waste water** dissolved and suspended waterborne waste which may consist of *sewage* and/or *trade waste*.

**Wet Riser Main System** one or more *riser mains* in a building with all *required* fittings, permanently charge with water from a *fire main*. The term includes all associated pipe work from the point of connection to a *fire main*.

**Window** includes a roof light, glass panel, glass brick, glass louvre, glazed sash, glazed door, or other device which transmits natural light directly from outside a building to the room concerned when in the closed position.

## A1.2 Adoption of Standards and other references

The adoption of a standard, rule, specification or provision included in any document issued by the standards association of Australia, standards

Association of New Zealand or other body, does not include a provision –

(a) specifying the respective rights, responsibilities or obligations between that body and any manufacturer, supplier or purchaser;

(b) specifying the responsibilities of any tradesman or other building operative, architect, engineer, authority, or other person or body;

(c) requiring the submission for approval of any material, building component, form or method of construction, to any person, authority or other body;

(d) specifying that a material, building component, form or method of construction, must be submitted to the Standards Association of Australia, Standards Association of New Zealand or other body or a committee of either Association for expression of opinion; or

(e) permitting a departure from the standard, rule, specification or provision at the sole discretion of the manufacturer or purchaser, or by arrangement or agreement between the manufacturer and purchaser.

## A1.3 Referenced Standards, Etc

A reference to a document under A1.2 refers to the latest edition or issue, together with any amendment, listed in specification A1.3 and only so much as is relevant in the context in which the document is quoted.

## A1.4 Differences between referenced documents and this Code

This Code overrules in any difference arising between it and any standard, rule specification or provision in a document listed in Specification A1.3. Further, references in this code to any standard or code of practice issued by the standards associations of Australia or of New Zealand or such other body, exclude the need for:

(a) compliance with NZS 1900 wherever it is quoted in any standard;

(b) compliance with any laws and regulations that are not of this country; and

(c) recognition of the meaning of “Engineer”.

Also, references to “FRR” in standards issued by the standards association of New Zealand mean “*Fire resistance level*” as defined in this Code.

---

**A1.5 Mandatory provisions**

(a) The following provisions of the Code are mandatory:

- (i) all provisions of Section A; and
- (ii) the performance requirements stated at the beginning of all the other sections.

(b) The Deemed-to-Satisfy Provision of the Code are one means of satisfying the performance requirements. The performance requirement can also be met by any other means. When this latter approach is taken, it must meet the final objectives and performance that would have been achieved had the Deemed-to-Satisfy Provisions been followed.

---

---

## ACCEPTANCE OF DESIGN AND CONSTRUCTION

### A2.1 Suitability of materials

Every part of a building must be constructed in a manner which will achieve the required level of performance, using materials and methods that are not faulty or unsuitable for the purpose for which they are intended.

### A2.2 Evidence of Suitability

Evidence to support the use of a material, method, form of construction or design may be –

- (a) a report issued by a *Registered Testing Authority*, showing that the material or form of construction has been submitted to the tests listed in the report, and setting out the results of those tests and any other relevant information that demonstrates its suitability for use in the building;
- (b) a current *Certificate of Accreditation*;
- (c) a certificate from an appropriately qualified *professional consultant* which –
  - (i) certifies that a material, design or form of construction complies with the requirement of this Code; and
  - (ii) sets out the basis on which it is given and the extent to which relevant specifications,

rules, codes of practice or other publications have been relied upon; or

- (d) a Standard Mark Certificate issued by the standards association of Australia or the standards association of new Zealand; or
- (e) Any other form of documentary evidence that correctly describes the properties and performance of the material or form of construction and adequately demonstrates its suitability for use in the building,

and any copy of documentary evidence submitted under this code, must be a complete copy of the original report or document.

### A2.3 Fire-resistance of building elements

The FRL of a *structural member* or other building element must be determined in accordance with specification A2.3. Any relevant testing or certification must be by an appropriately qualified *professional consultant* or *Registered testing authority*.

### A2.4 Early Fire Hazard Indices

The Early Fire Hazard Indices of a component or assembly must be determined in accordance with Specification A2.4.

---

## CLASSIFICATION OF BUILDINGS AND STRUCTURES

### A3.1 Principles of classification

The classification of a building or part of a building is determined by the purposes for which it is designed, constructed or adapted to be used.

### A3.2 Classifications

Buildings are classified as follows:-

**Class 1:** a residence which may comprise one or more buildings including any habitable outbuildings which in association constitute –

- (a) a single dwelling-house; or
- (b) a terrace house, townhouse or the like which may be detached or separated by a *common wall*; or
- (c) a dwelling-house used as a boarding-house, hostel, or the like, in which not more than 12 persons would ordinarily be resident; or
- (d) a building that does not exceed a *rise* of 3 storeys and contains –
  - (i) 2 or more *sole-occupancy units* located one above the other,
  - (ii) only 2 *sole-occupancy units* located one above the other,

and each unit has direct egress to a road or *open space*.

**Class 2:** a building containing 2 or more *sole-occupancy units* each being a separate dwelling, other than a building of class 1.

**Class 3:** a residential building, other than a building of class 1 or 2, which is a common place of living for a number of unrelated persons, including –

- (a) a boarding-house, guest house, hostel, or lodging-house;
- (b) a residential part of an hotel or motel;
- (c) a residential part of a *school*;
- (d) accommodation for the aged, disable or children; and
- (e) a residential part of a *health-care building* which accommodates members of staff.

**Class 4:** a dwelling in a building that is class 5,6,7,8 or 9 if it is the only dwelling in the building.

**Class 5:** an office building used for professional or commercial purposes, excluding buildings of class 6, 7 or 8.

**Class 6:** a shop or other building for the sale of goods by retail or the supply of services direct to the public, including-

- (a) an eating room, café, restaurant, milk or soft-drink bar;
- (b) a dining room, bar, shop or kiosk portion of an hotel or motel;
- (c) a hairdresser's or barber's shop, public laundry, or undertaker's establishment;
- (d) market or sale room, show room, or service station.

**Class 7:** a building which is –

- (a) for storage, or display of goods or produce for sale by wholesale; or
- (b) a *public carpark*.

**Class 8:** a laboratory, or a building in which a handicraft or process for the production, assembling, altering, repairing, packing, finishing, or cleaning of goods or produce is carried on for trade, sale, or gain.

**Class 9:** a building of a public nature –

- (a) **Class 9a** – a *health-care building*
- (b) **Class 9b** – an *assembly building*, and

Class 9a includes a pathology laboratory in a *health-care building* and Class 9b includes a trade workshop in a primary or secondary school, but excludes any other part of these building that are of another Class.

**Class 10:** a non-habitable outbuilding or structure –

- (a) **Class 10a** – a carport, *private garage*, shed or the like;
- (b) **Class 10b** – a fence, mast, antenna, retaining or free-standing wall, *swimming pool*, or the like.

### A3.3 Multiple classification

Each part of a building must be classified separately, and -

- (a) where parts have different purposes – if not more than 10% of the *floor area of storey* which is not a laboratory is used for a purpose which is a

---

different classification, the classification applying to the major use may apply to the whole *storey*;

(b) Classes 9a, 9b, 10a and 10b are separate classifications; and

(c) a reference to –

(i) Class 9 – is to Class 9a or 9b; and

(ii) Class 10 – is to Class 10a or 10b

---

---

## UNITED BUILDINGS

### A4.1 When buildings are united

Two or more buildings adjoining each other are considered to form one united building if they –

- (a) are connected through openings in the walls dividing them; and
- (b) together comply with all the requirements of this code as though they are a single building.

### A4.2 Alterations in a united building

After any *alteration* or any other action –

- (a) a united building; or
- (b) each building forming part of a united building; or
- (c) each building if they cease to be connected through openings in the dividing walls,

must comply with all requirements for a single building.

---



## STANDARDS ADOPTED BY REFERENCE

### 1. Schedule of referenced documents

The standards and other documents listed in Table1 are referred to this Code. In order to reduce possible confusion/conflict, the standards produced by the standards association of Australia or by the standards association of New Zealand as seen to be specifically relevant, have been called up. However the code users are free to use any

suitable mix of Australian and New Zealand standards provided care is taken to follow consistent technical principles and prevalent practices. Where the standards from either Australia or New Zealand do not cover any specific area, the relevant standards issued by the British standards institution or the American society for testing and materials may be used.

<b>TABLE 1 SCHEDULE OF REFERENCE DOCUMENTS</b>		
No.	Title	Code Clause
AS1038	Methods for the analysis and testing of coal and coke	
Part 15	Fusibility of higher rank coal ash and coke ash	Spec NC3.15
AS1170	Minimum design loads on structure (SAA Loading Code)	B1.2
Part 2	Wind forces	
AS1349	Bourdon tube pressure and vacuum Gauges	Spec NE1.2
AS1428	Design rules for access by the disabled	ND3.2, ND3.3, NF2.5
Part 1	Regulatory requirements	
AS1530	Methods of fire tests on building materials components and structures	A1.1
Part 1	Combustibility test for materials	
Part 2	Test for flammability of materials	
Part 3	Test for early fire hazard properties of material	Spec A2.4
Part 4	Fire-resistance tests on elements of building construction	Spec A2.4 Spec ND3.15
AS 1657	Rules for fixed platforms, walkways, stairways and ladders	ND2.18, NH1.6, DF6.11.5
AS/NZS 1664	Rules for the use of aluminum in structures (SAA Aluminum Structures Code)	B1.3
AS/NZS 1668	Rules for the use of mechanical ventilation and air-conditioning in buildings (SAA Mechanical Ventilation and Air-Conditioning Code)	
Part 1	Fire precautions in building with air-handling systems	NC3.15, NE2.7 Spec NE1.8 Spec NE1.9, NH1.2 DF4.5, NF4.5.
Part 2	Ventilation requirements	NF4.11

**TABLE 1** Continued  
**SCHEDULE OF REFERENCED DOCUMENT**

No	Title	Code Clause(s)
AS 1670	Automatic fire alarm installations (SAA Code for Automatic Fire Alarm Installations)	Spec NE1.8 NE2.5
AS 3660	Protection of buildings from subterranean termites – prevention, detection and treatment of infestation.	B1.3
AS1720	Rules for the use of timber in structures (SAA Timber Engineering Code)	B1.3 Spec A2.3
AS1735	Design, installation, testing and operation of lifts, escalators and moving walks (SAA Lift Code)	
Part 2	Passenger and goods lifts – Electric	Spec NC1.5 NE3.4
Part 11	Fire-rated landing doors	NC3.10
Part 12	Facilities for persons with disabilities	ND3.3
AS/NZS 4200	Pliable building membranes and underlays.	DF1.5, NF1.5
AS 1860	Code of practice for the installation of particleboard flooring	B1.3
AS 1926	Fences and gates for private swimming pools	DG1.1 NG1.1
AS 2107	Code of practice for ambient sound levels for areas of occupancy within buildings	Spec NE1.9
NZS 2139	Heat actuated fire detectors	Spec NE1.8
AS 2159	Rules for the design and installation of piles (SAA Piling Code)	B1.3
AS/NZS 2179	Metal rainwater goods – Specification	NF7.2
AS 2180	Metal rainwater goods – Selection and installation	NF7.2 Spec NF7.2
AS 2185	Fibrous plaster products	Spec NC1.5
AS/NZS 2293	Emergency evacuation lighting in buildings	
Part 1	Design and installation	NE4.4, NE4.8
AS 2327	Composite construction in structural Steel and concrete (SAA Composite Construction Code)	Spec A2.3
AS 2601	The demolition of structures	B2.2

<b>TABLE 1 Continued</b>		
<b>SCHEDULE OF REFERENCED DOCUMENT</b>		
No	Title	Code Clause(s)
AS 2665	Smoke/heat venting systems	NC2.3,NE2.5, Spec NE2.6
AS 2818	Guide to swimming pool safety	DG1.1, NG1.1
AS 2870	Residential slabs and footings	
Part 1 – XXXX	Construction	B1.3, DF1.1, NF1.9
AS/NZS 2904	Damp-proof courses and flashings	DF1.8, NF 1.9
AS/NZS 3000	SAA Wiring rules	DE 1.1, NE6.1
NZS 3101	The design of concrete structures	B1.3
Parts 1 and 2		
NZS 3109	Specification for concrete construction	B1.3
NZS 3124	Specification for concrete construction for minor works	B1.3
NZS 3404	Code for design of steel structures (incorporating AS 1250)	B1.3
AS 3500	Plumbing and drainage Code	
Part 0	Glossary of terms	
Part 1	Water supply	DF5.2, DF5.3, NF5.2, NF5.3
Part 2	Sanitary plumbing and sanitary drainage	DF6.2, NF6.2
Part 4	Hot water supply systems	DF5.2, DF5.3, DF5.4, NF5.2, NF5.3, NF5.4
AS3600	Concrete Structures	Spec A2.3
NZS 3603	Code of practice for timber design	B1.3
AS 3700	Masonry in building (SAA Masonry Code)	Spec A2.3
AS 4100	Steel Structures	Spec A2.3
NZS 4121	Design for access and use of buildings and facilities by disabled persons	ND3.2, ND3.3, NF2.5
NZS 4122	Guide to approachability, accessibility and usability of buildings	ND3.2, ND3.3, NF2.5

**TABLE 1** Continued  
**SCHEDULE OF REFERENCED DOCUMENTS**

No	Title	Code Clause (s)
NZS 4203	General structural design and design loadings for buildings-	B1.2, B1.4
Part 1	General	
Part 2	Dead and live loads	
Part 3	Earthquakes provisions	
NZS 4210	Code of practice for masonry buildings, materials and workmanship	Spec A2.3, B1.3
NZS 4223	Code of practice for glazing in buildings	B1.3, Fig B1.4
NZS 4229	Code of practice for masonry buildings not requiring specific design	B1.3
NZS 4230	Code of practice for the design of masonry structures	B1.3
NZS 4232	Performance criteria for fire resisting closures	Spec NC3.4, NC3.6
NZS 4503	Hand operated fire fighting equipment	NE1.5, NE1.3
AS/NZS 1221	Specification for fire hose reels	NE1.5
NZS 4510	Code of practice for riser mains for fire service use	NE1.2, NE1.3
NZS 4512	Fire alarm systems in buildings	Spec NE1.8, NE2.5
NZS 4541	Automatic fire sprinkler systems	Table NC2.2, Spec NE1.2 Spec NE1.6
AS/NZS 2293	Emergency lighting in buildings	NE4.4, NE4.8
TR 440	NBTC Technical Record 440 – Guidelines for the testing and evaluation of Products for cyclone-prone areas	B1.3
AISC	Guidelines for assessment of fire resistance of structural steel members	Spec A2.3
ASTM E72-80	Standard method of conducting strength tests of panels for building construction	Spec NC1.5
ASTM E695-79	Method for measuring relative resistance of wall, floor and roof construction to impact loading (1985)	Spec NC1.5

---

## FIRE-RESISTANCE OF BUILDING ELEMENTS

### 1. Scope

This specification sets out the procedure for determining the FRL of *structural members* and other building elements

### 2. Rating

A building element has a FRL if –

- (a) it is listed in, and complies with Table 1 of this Specification;
- (b) it is identical with a prototype that has been submitted to the *Standard Fire Test* and the FRL achieved by the prototype is confirmed in a report from a *Registered Testing Authority* which –
  - (i) describes the method and condition of test and the form of construction of the tested prototype in full; and
  - (ii) certifies that the application of restraint to the prototype complied with the *Standard Fire Test*;
- (c) It differs in only a minor degree from a prototype tested under (b) and the FRL attributed to the *structural member* is confirmed in a report from a *Registered Testing Authority* which –
  - (i) certifies that the *structural member* is capable of achieving the FRL despite the minor departures from the tested prototype; and
  - (ii) describes the materials, construction and conditions of restraint which are necessary to achieve the FRL;
- (d) it is designed to achieve the FRL in accordance with –
  - (i) AS 4100, AS 2327 and AISC *Guidelines for Assessment of Fire Resistance of Structural Steel Members* if it is a steel or composite structure; or
  - (ii) AS 3600 if it is a concrete structure; or
  - (iii) AS 1720.4 if it is a solid or glued-laminated timber structure.
- (e) the FRL is determined by calculation based on the performance of a prototype in the *Standard Fire Test* and confirmed in a report in accordance with Clause 3.

### 3. FRLs determined by calculation

If the FRL of a building element is determined by calculation based on a tested prototype –

- (a) the building element may vary from the prototype in relation to –
  - (i) length and height if it is a wall;
  - (ii) height if it is a column;
  - (iii) span if it is a floor, roof or beam;
  - (iv) conditions of support; and
  - (v) to a minor degree, cross-section and components.
- (b) the report must demonstrate by calculation that the building element would achieve the FRL if it is subjected to the regime of the standard *fire test* in relation to –
  - (i) *Structural adequacy* (including deflection);
  - (ii) *Integrity*; and
  - (iii) *Insulation*; and
- (c) the calculation must take into account –
  - (i) the temperature reached by the components of the prototype and their effects on strength and modulus of elasticity;
  - (ii) appropriate features of the building elements such as support, restraint, cross-sectional profile, length, height, span, slenderness ratio, reinforcement, ratio of surface area to mass per unit length, and fire protection;
  - (iii) features of the prototype that influenced its performance in the *Standard Fire Test* although these features may not have been taken into account in the design for dead and live load;
  - (iv) features of the conditions of test, the manner of support and the position of the prototype during the test, that might not be reproduced in the building element if it is exposed to fire; and

- 
- (v) the design load of the building element in comparison with the tested prototype.

**1 Interchangeable materials**

- (a) Concrete and plaster – The FRL achieved with any material of Group A, B,C,D or E as an ingredient in concrete or plaster, applies equally when any other material of the same group is used in the same proportions:

Group A: Any portland cement.

Group B: Any lime.

Group C: Any dense sand.

Group D: Any dense calcareous aggregate, including any limestone or any calcareous gravel.

Group E: Any dense siliceous aggregate, including any basalt, diorite, dolerite, granite, granodiorite or trachyte.

- (b) Perlite and vermiculite – The FRL achieved with either gypsum perlite plaster or gypsum-vermiculite plaster applies equally for both plasters.

**5. Columns Covered with lightweight construction**

- (a) Protection against injury-If the fire-resisting covering of a steel column is *lightweight* construction –

(i) the covering must be protected by metal or other suitable material if the column is liable to damage from the movement of vehicles, materials or equipment; and

(ii) the voids must be filled solid with non-combustible material to a height of not less than 1.2m above the floor to prevent indenting if the covering is not in continuous contact with the column; and

- (b) Sealing at floor level – A plug of non-combustible materials must seal all voids at each floor level, including voids between the column and its covering if –

(i) A steel column extends through 2 or more storeys; and

(ii) The fire-resisting covering is not in continuous contact with the column.

**TABLE 1  
FRLs DEEMED TO BE ACHIEVED BY CERTAIN BUILDING ELEMENT**

BUILDING ELEMENT	THICKNESS OF PRINCIPAL MATERIAL (mm)			ANNEXURE REFERENCE Clause No
	60/60/60	90/90/90	120/120/120	
<b>WALL</b> <b>Masonry-</b> Concrete with material density in Kg/M <sup>3</sup> of- -1600 or more -less than 1600 <b>Concrete</b> - Reinforced/Prestressed <b>Gypsum-perlite or Gypsum-Vermiculite</b> plaster on metal lath and channel	80  70    50	100  90    50	120  110    65	1,2,3,4,5 1,2,3,4,5         1,5,7
<b>CONCRETE COLUMN</b> <b>Concrete-</b> - Reinforced/Prestressed	See 2 (d)(ii) of this Specification and 6 Annexure to this Table			
<b>HOT-ROLLED STEEL COLUMN</b> (Including a fabricated column) exposed on no more than 3 sides. <b>Fire protection of-</b> <b>Concrete – Cast</b> In-situ- <i>-loadbearing</i>  <i>non-loadbearing</i> -unplastered -plastered 13 mm <b>Gypsum-perlite Or Gypsum Vermiculite plaster</b> - sprayed to contour - sprayed on metal lath	25    25 25   20 20	         30 25   25 20	         40 30   35 25	         8,9,10,11         8,9,10,11 1,5,8,9,10,11         1,10 1,7

<b>TABLE 1 Continued</b>				
<b>FRLs DEEMED TO BE ACHIEVED BY CERTAIN BUILDING ELEMENTS</b>				
BUILDING ELEMENTS	THICKNESS OF PRINCIPAL (mm)			ANNEXURE REFERENCE Clause No.
	60/60/60	90/90/90	120/120/120	
<b>HOT-ROLLED STEEL COLUMN</b> (including a fabricated column) exposed on 3 sides:				
<b>Fire protection of-</b>				
<b>Solid concrete masonry-</b>				
column spaces filled	50	50	50	1,2,3,4,5,8,9,11
column spaces unfilled	50	50	65	1,2,3,4,8,11
	60/-/-	90/-/-	120/-/-	
<b>HOT-ROLLED STEEL COLUMN</b> (Including a fabricated column) exposed on 4 sides				
<b>Fire protection of-</b>				
<b>Concrete – Cast in situ-</b>				
-loadbearing	25	40	45	8,9,10,11
non-loadbearing-				
-unplastered	25	30	40	8,9,10,11
-plastered 13 mm	25	25	30	1,5,8,9,10,11
<b>Gypsum-perlite Or Gypsum- Vermiculite plaster</b>				
-sprayed to contour	25	30	40	1,10
-sprayed on metal lath	20	20	30	1,7
<b>HOT-ROLLED STEEL COLUMN</b> (Including a fabricated column) exposed on 4 sides				
<b>Fire protection of-</b>				
<b>Solid concrete masonry</b>				
Column spaces filled	50	50	50	1,2,3,4,5,8,9,11
Column spaces unfilled	50	50	50	1,2,3,4,5,8,11



<b>TABLE 1 Continued</b>				
<b>FRLs DEEMED TO BE ACHIEVED BY CERTAIN BUILDING ELEMENTS</b>				
BUILDING ELEMENTS	THICKNESS OF PRINCIPAL MATERIAL (mm)			ANNEXURE REFERENCE Clause No
	60/60/60	90/90/90	120/120/120	
<b>BEAM</b>				
<b>Concrete –</b>				
Reinforced/Prestressed see 2 (d)(ii) of this Specification and clause 6 of Annexure to this Table				
<b>Hot-Rolled Steel</b> (Including an open-web joist, girder, truss, etc) Exposed on no more than 3 sides:				
Fire protection of-				
<b>Concrete – Cast in-Situ-</b>	25	30	40	8,10,11
<b>Gypsum-perlite or Gypsum vermiculite plaster</b>				
- sprayed to contour	20	25	35	1,10
- Sprayed on metal lath	20	20	25	1,7
	60/-/-	90/-/-	120/-/-	
<b>Hot-rolled Steel</b> (incl. an open-web joist, girder, truss, etc) exposed on 4 sides:				
Fire protection of-				
<b>Concrete – Cast in situ</b>	25	40	45	8,10,11
<b>Gypsum-perlite or Gypsum-vermiculite plaster</b>				
- sprayed to contour	25	30	40	1,10
- spread on metal lath	20	20	30	1,7
	60/60/60	90/90/90	120/120/120	
<b>FLOOR, ROOF OR CEILING</b>				
<b>Concrete-</b>				
Reinforced/Prestressed see 2 (d) (ii) of this Specification and clause 6 of Annexure to this table				

---

## ANNEXURE TO TABLE 1

### 1. MORTAR, PLASTER AND PLASTER REINFORCEMENT

#### 1.1 Mortar for masonry

Masonry units of concrete must be laid in cement mortar or composition mortar complying with the relevant provisions of NZS 4210.

#### 1.2 Gypsum-perlite and gypsum-vermiculite plaster

Gypsum-perlite or gypsum-vermiculite plaster must be applied –

- (a) in either one or 2 coats each in the proportions of 1 m<sup>3</sup> of perlite or vermiculite to 640 kg of gypsum if the *required* thickness of the plaster is not more than 25mm; and
- (b) in 2 coats if the *require* thickness is more than 25 mm, the first in the proportion of 1 m<sup>3</sup> of perlite or vermiculite to 800 kg of gypsum and the second in the proportion of 1 m<sup>3</sup> of perlite or vermiculite to 530 kg of gypsum.

#### 1.3 Plaster of cement and sand or cement, lime and sand

Plaster prescribed in Table 1 must consist of –

- (a) cement and sand or cement, lime and sand; and
- (b) may be finished with gypsum, gypsum-sand, gypsum-perlite or gypsum-vermiculite plaster or with lime putty.

#### 1.4 Plaster reinforcement

If plaster used as fire-protection on walls is more than 19 mm thick –

- (a) it must be reinforced with expanded metal lath that –
  - (i) has a mass per unit area of not less than 1.84 kg/m<sup>2</sup>
  - (ii) has not fewer than 98 meshes/m; and
  - (iii) is protected against corrosion by galvanising or other suitable method; or
- (b) 13 mm x 13 mm x 0.710 mm galvanised steel wire mesh; and

- (c) the reinforcement must be securely fixed at a distance from the face of the wall of not less than 1/3 of the total thickness of the plaster.

### 2. Dimensions of masonry

The thickness of masonry of calcium-silicate, concrete and fired clay are calculated as follows:

#### 2.1 Solid units

For masonry in which the amount of perforation or coring of the units does not exceed 25% by volume (based on the overall rectangular shape of the unit) the thickness of wall must be calculated from the manufacturing dimension of the units and the specified thickness of the joints between them as appropriate.

#### 2.2 Hollow units

For masonry in which the amount of perforation or coring of the units does not exceed 25% by volume (based on the overall rectangular shape of the unit) the thickness of wall must be calculated from the equipment thickness of the unit and the specified thickness of the joints between them as appropriate.

#### 2.3 Equivalent thickness

The equivalent thickness of a masonry unit is calculated dividing the net volume by the area of one vertical face.

#### 2.4 Cavity walls

The thickness of a cavity wall is the sum of the thickness of the leaves determined in accordance with 2.1 and/or 2.2 as appropriate.

#### 2.5 Cavity walls of different materials

If the 2 levels of a cavity wall are of units of different type the thickness required is that listed for the less fire-resistance material (i.e. the greater thickness).

### 3. SLENDERNESS RATIO OF MASONRY

#### 3.1 Maximum value

The slenderness ratio of the masonry wall must not exceed the appropriate value in Table 3.1.

### 3.2 Calculation

The slenderness ratio of a masonry wall is calculated accordance with AS 3700. In the case of cavity walls it is calculated for each leaf separately. Each leaf must satisfy 3.1.

<b>TABLE 3.1 MAXIMUM SLENDERNESS RATIOS FOR MASONRY WALLS</b>			
TYPE OF UNIT			
	60/60/60	90/90/90	120/120/120
<b>Concrete</b> in which the basalt content of the aggregate is			
Less than 45%	18	17	16
45% or more	22.5	21	19.5
<b>Reinforced masonry</b> – all types of unit designed for-			
axial forces and flexure –	27	27	27
flexure-with super-imposed axial forces less than 5% of load capacity-	36	36	36

### 3 PROTECTION TO MASONRY REINFORCEMENT

In a building element of reinforced masonry designed for fire-resistance, the distance from the surface of the element to the surface of the reinforcement must not be less than –

- (a) for FRL 60/60/60/ or 90/90/90 – 30 mm;
- (b) for FRL 120/120/120 – 40 mm;

### 4 INCREASE IN THICKNESS BY PLASTERING

#### 5.1 General

The tabulated thicknesses are those of the principal material. They do not include the thickness of plaster which must be additional to the listed thickness of the material to which it is applied.

#### 5.2 Walls

If a wall of concrete masonry is plastered on both sides to an equal thickness, the thickness of the wall for the purposes of Table (but not for the purposes of Table 3.1) may be increased by the following

proportions of the thickness of the plaster on one side:

- (a) For concrete masonry in which the aggregate is of a density in excess of 1800 kg/m<sup>3</sup> : 100%
- (b) For concrete masonry in which the aggregate is of a density between 16000 and 1800 kg/m<sup>3</sup> : 85%.
- (c) For concrete masonry in which the aggregate is of a density less than 1600 kg/m<sup>3</sup> : 75%

### 5 CONCRETE SLABS BEAMS WALLS AND COLUMNS

The requirements to meet specific values of FRL are those contained in AS 3600. However for simple structures the following procedures may be adopted.

#### 6.1 Structural adequacy criterion

Table 6.1A gives the minimum dimensions for meeting specific levels of *structural adequacy* for –

- (a) Solid or hollow-Core plain slabs      the clear cover to the longitudinal reinforcement or tendons. A slab is continuous if it is flexurally Continuous along at least one edge under the imposed loads.
- (b) Ribbed slabs with ribs spaced at not more than 1200 mm centre to centre      The minimum width of the rib and the clear cover to the reinforcement or tendons of the ribs. The slabs spanning the ribs may be treated as plain slabs as at (a).
- (c) Beams      The minimum width of web (rectangular or uniformly tapering cross-section) and the clear cover to the reinforcement or tendons. The upper surface of the beams must be integral with a slab or protected by one
- (d) Solid or hollow Core vertical wall      The clear cover to the reinforcement or tendons. The effective thickness of the wall must be at least equal to that given in Table 6.3 for the FRL for the *insulation* criterion equal in period to the *required*

---

*structural adequacy* criterion. In addition the slenderness ratio must not exceed the values given in Table 6.1B.

(e) Columns which are

Exposed on all sides of fire

Built into or form part of a wall that does not have a fire separating function

Built into or form part of a wall that has a lower value of *structural adequacy* than *required* for the column; or

Built into and protrude by a distance in excess of the value of the clear cover to the longitudinal reinforcement.

The minimum cross-sectional dimension and the clear cover to the reinforcement

## 6.2 Integrity criterion

This criterion is relevant only for slabs and walls and not for ribs, beams and columns. It is satisfied if the criteria for *structural adequacy* and *insulation* are met for the period equal to that *required* of the *integrity* of the slab or wall as appropriate.

## 6.3 Insulation criterion

This criterion is also relevant only for slab and walls. It is met by meeting the requirement for minimum effective thickness solid slabs and walls is the actual thickness. The effective thickness of hollow core slabs and walls is the value of the net cross-section area divided by the width of the cross-section. With hollow core slabs and walls the thickness of the nearest surface must be not less than 25 mm or 20% of the effective thickness of the slab.

**TABLE 6.1A  
FRL – REQUIREMENTS FOR STRUCTURAL ADEQUACY CRITERION**

BUILDING ELEMENT	FRL (Minutes)			
	30	60	90	120
<b>Plain Slabs</b>				
- Simply supported one-way, clear cover (mm) to				
- reinforcement	15	20	25	30
- tendons	20	25	35	40
- Simply supported two way, clear cover (mm) to				
- reinforcement	10	15	20	25
- tendons	15	20	30	35
Continuous one-way and two way, clear cover (mm) to				
- reinforcement	10	15	15	15
- tendons	15	20	25	25
<b>Ribs of plain slabs</b> min width x clear cover (mm) (mm)				
- simply supported one-way and two-way ribbed slabs				
- reinforcement	80x15	110x25	135x35	150x45
- tendons	80x25	110x35	135x45	150x55
- continuous one way and two-way ribbed slabs min. width x clear cover (mm) (mm)				
- reinforcement	70x15	75x20	110x25	125x35
- tendon	70x25	75x30	110x35	125x45

**TABLE 6.1A** Continued

**FRL – REQUIREMENT FOR STRUCTURAL ADEQUACY CRITERION**

BUILDING ELEMENT	FRL (Minutes)			
	30	60	90	120
<p><b>Beams</b> min. width      clear of web      x      cover (mm)              (mm)</p> <p>Simply supported –</p> <p>- reinforcement</p> <p>- tendon</p> <p>Continuous –</p> <p>- reinforcement</p> <p>- tendon</p>	<p>75x20</p> <p>75x25</p> <p>75x20</p> <p>75x25</p>	<p>120x30 or 150x25 or 240x20</p> <p>120x35 or 150x30 or 240x25</p> <p>120x120</p> <p>120x25</p>	<p>150x45 or 200x35 or 300x30 or 500x25</p> <p>150x55 or 200x45 or 300x40 or 500x35</p> <p>150x25 or 200x20</p> <p>150x35 or 200x30</p>	<p>200x55 or 240x45 or 360x40 or 600x33</p> <p>200x65 or 240x55 or 360x50 or 600x43</p> <p>200x35 or 240x25 or 380x20</p> <p>200x45 or 240x35 or 380x30</p>
<p><b>Vertical Walls</b> Clear cover in mm</p> <p>- to reinforcement</p> <p>- to tendons</p>	<p>20</p> <p>30</p>	<p>20</p> <p>30</p>	<p>35</p> <p>30</p>	<p>40</p> <p>30</p>
<p>Note:- Vertical walls must also satisfy the requirements of Table 6.1B</p>				
<p><b>Columns</b> min cross      clear Sectional      x      cover Dimension      (mm) (mm)              -to reinforcement</p>	<p>150x10</p>	<p>200x20 or 240x15</p>	<p>250x35 or 300x25</p>	<p>300x45 or 400x35</p>

<b>TABLE 6.1 B MAXIMUM ALLOWABLE SLENDERNESS RATIO FOR CONCRETE WALLS</b>	
Ratio of design axial Force to the product of Gross cross-section area And the characteristic compressive Cylinder strength at 28 days	Corresponding maximum Value of slenderness ratio (effective height/thickness)
0.0	50
0.005	35
0.03	20
0.10	15
Notes:	
1. Values in between can be interpolated. 2. Design axial force = 1.1 dead load + 0.6 live load including impact. 3. The characteristic compressive strength in MPa is generally expressed as the grade of the concrete.	

<b>TABLE 6.3 MINIMUM EFFECTIVE THICKNESS FOR INSULATION</b>	
FRL for <i>Insulation</i> criterion Minute	Effective thickness mm
30	60
60	80
90	100
120	120

## 7. GYPSUM-PERLITE OR GYPSUM-VERMICULITE PLASTER OR METAL LATH

### 7.1 Walls

In walls fabricated of gypsum-perlite or gypsum-vermiculite plaster on metal lath and channel –

- (a) the lath must be securely wired to each side of 19 mm x 0.44 kg/m steel channels (used as studs) Spaced at not more than 400 mm centres; and
- (b) the gypsum-perlite or gypsum-vermiculite plaster must be applied symmetrically to each exposed side of the lath.

### 7.2 Columns

For the fire protection of steel columns with gypsum-perlite or gypsum-vermiculite on metal lath –

- (a) the thickness of the plaster must be measured from the back of the lath;
- (b) the lath must be fixed at not more than 600 mm centres vertically to steel furring channels, and –
  - (i) if the plaster is to be 35 mm thick or more at least 12 mm clear of the column; or
  - (ii) if the plaster is to be less than 35 mm thick – at least 6 mm clear of the column; or
- (c) the plaster may be applied to self-furring lath with furring dimples to hold it not less than 10 mm clear of the column.

### 7.3 Beams

For the fire protection of steel beams with gypsum-perlite or gypsum-vermiculite on metal lath –

- (a) the lath must be fixed at not more than 600 mm centres to steel furring channels and at least 20 mm clear of the steel;
- (b) the thickness of the plaster must be measured from the back of the lath.

## 8 EXPOSURE OF COLUMNS AND BEAMS

### 8.1 Columns

A column incorporated in or in contact on one or more sides with a wall of solid masonry or concrete at least 100 mm thick may be considered to be exposed to fire on no more than 3 sides.

### 8.2 Beams.

A beam, open-web joist, girder or truss in direct and continuous contact with a concrete slab or a hollow block floor or roof may be considered to be exposed to fire on no more than 3 sides.

## 9. FILLING OF COLUMN SPACES

If steel columns are deemed to have FRLs of more than 120/-/, the spaces between the fire-protective material and the steel (and any re-entrant parts of the column itself) must be filled solid with a fire-protective material like concrete or gROUT.

## 10. REINFORCEMENT FOR COLUMN AND BEAM PROTECTION

### 10.1 Masonry

Concrete masonry for the protection of steel columns must have steel-wire or mesh reinforcement in every second course and lapped at the corners.

### 10.2 Structural concrete

If a steel column or a steel beam is to be protected with structural concrete –

- (a) the concrete must be reinforced with steel-wire mesh or steel-wire binding placed about 20 mm from its outer surface; and
- (b) for concrete less than 50 mm in diameter; and
  - (i) at least 3.15 mm in diameter; and
  - (ii) spaced at not more than 100 mm vertically; or
- (c) for concrete not less than 50 mm thick, the steel wire must be either –

- (i) of a diameter and spacing in accordance with (b); or
- (ii) at least 5 mm in diameter and spaced at not more than 150 mm vertically.

### 10.3. Gypsum-perlite or gypsum-vermiculite plaster sprayed to contour

- (a) If a steel column or steel beam is protected with either gypsum-perlite or gypsum-vermiculite plaster sprayed to contour and the construction falls within the limits of Table 10.3, the plaster must be reinforced with –
  - (i) expanded metal lath complying with Clause 1.4; or
  - (ii) galvanised steel mesh complying with Clause 1.4.
- (b) The reinforcement must be placed at a distance from the face of the plaster of at least 1/3 of the thickness of the plaster and must be securely fixed to the column or beam at intervals of not more than the relevant listing in Table 10.3.
- (c) For the purposes of Table 10.3 –
  - (i) “vertical” includes a surface at not more than 10° to the vertical;
  - (ii) “horizontal” includes a surface at not more than 10° to the horizontal; and
  - (iii) “underside” means the underside of any horizontal or non-vertical surface.

## 11. THICKNESS OF COLUMN AND BEAM PROTECTION

### 11.1 Measurement of thickness

The thickness of the fire-protection to steel columns and steel beams (other than fire protection of gypsum-perlite or gypsum-vermiculite plaster sprayed on metal lath or sprayed to contour) is to be measured from the face or edge of the steel, from the face of a splice plate or from the outer part of rivet or bolt, whichever is the closest to the outside of the fire-protective construction, except that-

- (a) if the thickness of the fire-protection is 40 mm or more, rivet heads may be disregarded; and



(b) if the thickness of the fire-protection is 50 mm or more-

(i) any part of a bolt (other than a high-tensile bolt) may be disregarded; and

(ii) a column splice plate within 900 mm of the floor may encroach upon the fire protection by up to a ¼ of the thickness of the fire protection;

**TABLE 10.3  
REINFORCEMENT OF GYPSUM-PERLITE OR GYPSUM-VERMICULITE  
PLASTER SPRAYED TO CONTOUR**

SURFACE TO BE PROTECTED	REINFORCEMENT REQUIRED IF SMALLER DIMENSION OF SURFACE EXCEEDS (mm)	MAX SPACING OF FIXINGS OF THE MESH TO SURFACE (mm)
<b>Members with H or I cross-section</b>		
Vertical	450	450
Non-vertical-	300	300
Underside-	300	300
Upperside of a Horizontal surface	Not required	
<b>Members with other shapes</b>		
Vertical	Any size	450
Non-Vertical	Any size	300
Upperside of a Horizontal surface-	Not required	

---

## EARLY FIRE HAZARD TEST FOR ASSEMBLIES

### 1. Scope

This Specification sets out the procedures for determining the Early Fire Hazard Indices of components and assemblies. These tests classify building materials, their surface finishes and furnishing according to :-

- (a) their tendencies to ignite;
- (b) their tendencies to spread flame;
- (c) the heat they develop once ignition has occurred; and
- (d) their tendencies to produce smoke.

### 2. Form of test

Tests must be carried out in accordance with AS 1530.3 and AS 1530.4

### 3. Test specimens

Test specimens must incorporate-

- (a) all types of joints; and
- (b) all types of perforations, recesses or the like for pipes, light switches or other fittings, which are proposed to be used for the member or assembly of members in the building.

### 4. Concession

Clause 3 does not apply to joints, perforations, recesses or the like that are larger than those in the proposed application and have already been tested in the particular form of construction concerned and found to comply with the conditions of test.

### 5. Smaller specimen permitted

A testing laboratory may carry out the test at pilot scale if a specimen (which must be not less than 900 mm) will adequately represent the proposed construction in the building, but the results of that test do not apply to construction larger than limits defined by the laboratory conducting the pilot examination.

---

NATIONAL  
BUILDING  
CODE  
2000

ALL BUILDINGS

SECTION **B**

---

## STRUCTURE

---

**Performance Requirements**  
**Deemed-to-Satisfy Provisions**

**B1**    **Structural Provisions**

**B2**    **Demolition**

---

---

# **SECTION B**

**THIS SECTION APPLIES TO ALL BUILDINGS**

---

# CONTENTS

## PERFORMANCE REQUIREMENTS

### DEEMED-TO-SATISFY PROVISIONS

Part		Part	
<b>B1</b>	<b>Structural Provisions</b>	<b>B2</b>	<b>Demolition</b>
B1.1	General requirements	B2.1	General Requirements
B1.2	Loads	B2.2.	Applicable standard
B1.3	Construction deemed-to-satisfy	B2.3	Dangerous buildings
B1.4	Human impact against glazing		

---

---

## PERFORMANCE REQUIREMENTS

### OBJECTIVES

**BP1** A building and all connected services must be designed and constructed to fulfil the following objectives:-

- (a) prevent death and injury to people from structural failure
- (b) avoid distress to occupants as a result of deflection vibration degradation or other similar causes
- (c) avoid damage to neighbouring property
- (d) the building must satisfy the intended use

**BP2** Procedures and methods of demolition must be adequate to prevent death and injury to persons and avoid damage to neighbouring property.

### REQUIRED PERFORMANCE

#### BP1.1 Design loads

Buildings and their elements must be designed and constructed in order to prevent structural failure during the expected life of the building and to avoid unacceptable deflections and vibrations during the normal use of the building, resulting from –

- (a) combinations and frequency of all possible loads, dynamic responses and internal actions;
- (b) the properties of the materials used in the building; and
- (c) the foundation conditions.

**BP1.1.1** The design and construction must take into account the loads resulting from the following acting either singly or in possible combinations –

- (a) self weight
- (b) imposed loads
- (c) temperature variations
- (d) earth pressure
- (e) wind
- (f) earthquake
- (g) resonance effects

- (h) impact
- (i) explosion/implosion
- (j) fire
- (k) water and other liquids
- (l) fatigue resulting from fluctuating loads
- (m) differential displacement
- (n) adverse effects due to closeness of other buildings
- (o) any other expected loads.

**BP 1.2** The design and construction must allow for –

- (a) the consequences of failure;
- (b) the quality of workmanship available;
- (c) variations in material properties and site characteristics; and
- (d) want of accuracy in the methods used to predict the structural performance of the building.

#### BP1.2 Site works

- (a) *Site* works as necessary must be carried out to ensure the stability of the building *site* during the expected life of the building.
- (b) While carrying out *site* works any damage to existing structures or adjacent property must be avoided.
- (c) Alterations to the ground water level resulting from *site* works must not be allowed to affect the stability of any building.

#### BP1.3 Design criteria

The following criteria must be satisfied –

- (a) during the designed life of the building the probability of experiencing unacceptable deflections or vibrations must not exceed 5%;
- (b) the probability of risk of structural failure must not exceed 0.1% within the designed life of the building;

---

## **BP2.1 Demolition of buildings**

While buildings are demolished the following must be ensured –

- (a) safety of the public and of the site personnel from injury or death;
- (b) avoidance of damage and nuisance from dust, vibrations, noise, water, fire, smoke and fumes;
- (c) continued access to other properties;
- (d) the exhibition of appropriate notices warning the public; and
- (e) prevention of damage to public services such as water and sewerage pipes, electricity and telephone line etc and allow their continued use.

### **BP2.1.1 Design and planning of demolition**

The method and sequence of demolition must be planned in detail with due allowance for the following –

- (a) the sudden release of locked up forces such as with prestressed concrete, arches, cantilevers etc;

- (b) the height of the structure;
  - (c) clear space available;
  - (d) the presence of dangerous or inflammable materials such as gas cylinders, aerosol spray cans, drums, containing flammable material or explosive dusts, foam plastics etc;
  - (e) the structural condition of the building;
  - (f) the presence of basement, cellars, vaults and other voids and if so the effect of removal of cross walls and the like;
  - (g) the requirement for any cutting, welding or burning;
  - (h) the requirement for temporary supports, shoring scaffolding and the like and the loads including impact loads that they may have to take;
  - (i) the loads from the stationing and operation of demolition equipment especially if supported on parts of the building being demolished; and
  - (j) any other likely factors.
-

## DEEMED-TO-SATISFY PROVISIONS

### STRUCTURAL PROVISIONS

#### B1.1 General requirements

8

0.8

Materials, components and methods of construction used in a building or structure and all attached services must be capable of sustaining at an acceptable level of safety and serviceability –

- (a) the most adverse combinations of loads (including combinations of loads that might result in potential for progressive collapse); and
- (b) other actions

to which they may reasonably be subjected.

#### B1.2 Loads

The loading requirements of B1.1 are satisfied if the building or structure can resist loads determined in accordance with the following;

##### (a) Wind loads:

AS1170 Minimum design loads on structures (known as SAA Loading Code)

Part 2- Wind loads

When using Part 2 of the Standard the following provisions apply:

a limit state basic wind speed of 70 m/s to all areas. The equivalent basic wind speed for permissible stress methods of design is 57 m/s. When the simplified procedure of AS 1170 part 2 is followed, the value of the factor  $B_1$ , to be applied is 2.3. The maps of Australia in the Standard are to be disregarded.

##### (b) Dead, Live and earthquake loads:

NZS4203 Part 1,2 and 3 General structural design and design loadings for buildings.

The maps of New Zealand shown in the Standard are to be disregarded. The earthquake zones for Vanuatu are marked in Figure B1.2. For use with NZS 4203 the zone factors corresponding to the zone numbers given in the figure are:-

Zone No.	Zone Factor
7	0.7

Each zone factor applies uniformly over the whole area of the zone.

**Note:** The zone numbers have been given on the basis of consistent values for Fiji, Vanuatu, Solomon Islands, and Niue. This means that any particular zone number such as zone 6 and the value of its zone factor, have the same meaning in the codes of all of these countries.

- (c) **Other loads:** The principles of structural mechanics.

#### B1.3 Construction deemed-to-satisfy

The requirements of B1.1 for materials and forms of construction are satisfied if they comply with the following:

##### (a) Masonry

- (i) Code of practice for masonry buildings, materials and workmanship: NZS 4210
- (ii) Code of practice for masonry buildings not requiring specific design: NZS 4229
- (iii) Code of practice for design of masonry structures: NZS 4230

##### (b) Concrete

- (i) The design of concrete structures: NZS3101 Parts 1 and 2
- (ii) Specification for concrete construction: NZS 3109
- (iii) Specification for concrete construction for minor works: NZS 3124

- (c) **Steel construction** – NZS 3404

- (d) **Aluminium construction:** AS/NZS 1664

- (e) **Timber construction** – Design of timber structures: AS 1720 or NZS 3603.



**FIGURE B1.2  
EARTHQUAKE ZONING MAP OF VANUATU**

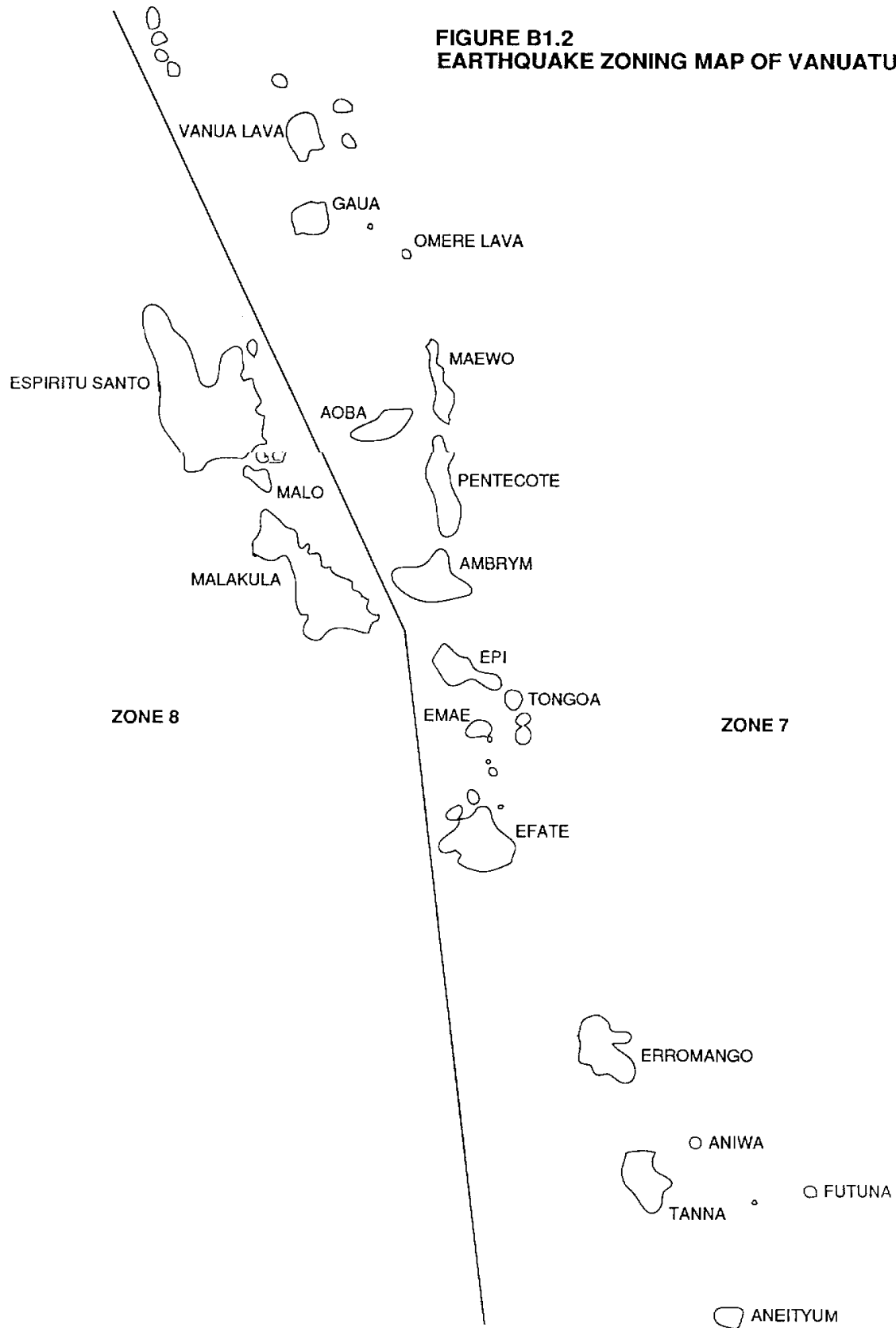

- (f) **Footings:** Footings for Class 1 and 10a buildings: AS 2870.1.
- (g) **Piling:** AS 2159.
- (h) **Glass installations:** NZS 4223 subject to B1.4.
- (i) **Protection from termites:** In areas subject to infestation by subterranean termites:
- (i) Physical barriers: AS 3660.
  - (ii) Soil treatment: AS 3660.
- (j) **Roof construction:**  
TR 440 and manufacturer's recommendations.
- (k) **Particleboard structural flooring:** AS 1860.
- (l) **External wall cladding:** No structural damage when tested to TR 440 to withstand impact from a 4 kg piece of timber of nominal cross-section 100mm x 50mm striking end on at a velocity of 15m/s.
- B1.4 Human impact against glazing**
- (a) Glazing of *windows* and other openings and their support systems designed only against wind loads are not safe against human impact. In order to provide for reasonable safety against injury or death resulting from glass breakage and possible falls, glazing and its support framing must be designed for the levels of risk shown in Table B1.4. The impact energy that the glass and its framing must resist for different levels of risk and for different configurations of glazing are given in Figure B1.4.
- (b) The following must be taken into account while designing glazing against human impact –
- (i) laminated glass and toughened glass are considered to be safety glass in terms of injury potential from fragments and splinters. Wired glass and heat-strengthened glass are not safety glasses.
  - (ii) annealed or laminated glass which has minor abrasion damage or has been sand blasted on the tension face has its impact strength severely reduced.
  - (iii) the strength of glass can be substantially reduced by the lapse of time.
- (c) The barrier protection shown in Figure B1.4 must be designed to NZS 4203. The deflection of the barrier must not exceed 50% of the distance between the hand rail and the glass when a concentrated force of 1.2 kN is applied to the face of the barrier.

<b>TABLE B1.4 RISK LEVEL FOR CLASS OF BUILDING FOR ASSESSMENT OF REQUIRED STRENGTH OF GLAZING</b>			
HEIGHT OF FALL IN CASE OF GLAZING FAILURE	RISK		
	HIGH	MEDIUM	LOW
More than 6m	2, 6, 9b	3,4,5,7,8,9a	-
3m to 6m	-	2,6, 9b	3,4,5,7,8,9a
Up to and including 3m	-	6, 9b	2,3,4,5,7,8,9a

GLAZING CONFIGURATION

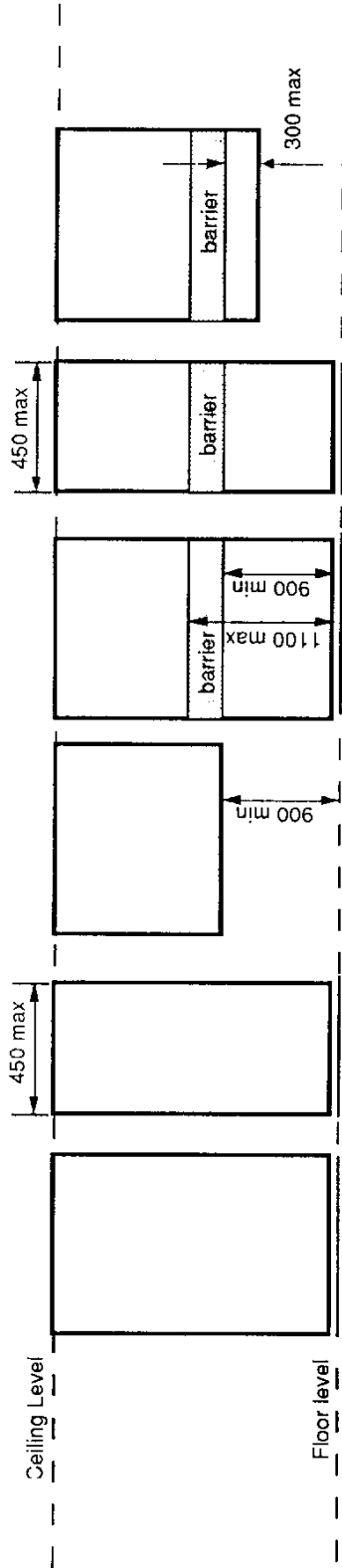

RISK LEVELS

High	600 Joules for containment Note 2	425 Joules for containment Note 2	Note 1	425 Joules for containment Note 2	250 Joules for containment Note 2	Note 2 breaksafe Note 3
Medium	425 Joules for containment Note 2	250 Joules for containment Note 2	Note 1	250 Joules for containment Note 2	Note 1	Note 1
Low	250 Joules for containment Note 2	150 Joules for containment Note 2	Note 1	150 Joules for containment Note 2	Note 1	Note 1

Notes:

- 1) No specific impact requirement. Select glass as per NZS 4223.
- 2) Containment - fracture of glass gives no significant penetration eg. laminated glass. Containment *required* for impacts up to and including level set.
- 3) Breaksafe - fracture of glass gives either relatively harmless pieces or insufficient penetration to cause injury eg. laminated or toughened glass.

FIGURE B1.4 CAPACITY REQUIRED OF GLAZING ELEMENTS AGAINST HUMAN IMPACT

---

## DEMOLITION

### B2.1 General requirements

All dangerous buildings as detailed in B2.3 must either be restored to *required* standards or be demolished. The planning and execution of demolition must:

- (a) not put at risk the safety and health of the public and of the workers;
- (b) avoid damage to other properties;
- (c) avoid nuisance to others;
- (d) allow continued access to other properties; and
- (e) prevent damage to public services and allow continued operation of such services.

### B2.2 Applicable Standard

The requirements of B2.1 are satisfied if demolition is carried out to AS 2601 – The demolition of structures.

### B2.3 Dangerous buildings

Any building which has any of the conditions or defects described below must be deemed to be a dangerous building, if such conditions or defects exist to the extent that the life, health, safety or property of the public or its occupants are endangered whenever:

- (a) any *required exit* is not of sufficient width or size or is not so arranged as to provide safe and adequate means of egress in case of fire or other emergency;
- (b) the stress in any materials or member due to all applicable loads, is more than 1.5 times the working stress or stresses allowed for new buildings of similar class and type of construction;
- (c) any portion of the building has been damaged by fire, earthquake, wind, flood or by any other cause, to such an extent that its structural strength or stability is materially less than it was before such catastrophe and is less by 33 percent or more than the minimum requirements for new buildings of similar class and type of construction;

- (d) any portion or member or attachment of the building is likely to fail, or to become detached or dislodged, or to collapse and thereby injure persons or damage property;
- (e) any portion of the building has suffered distortion, cracking or settlement to such an extent that walls or other structural portions have materially less resistance to winds or earthquakes that is *required* in the case of similar new construction;
- (f) the building or any portion of it is likely to collapse or fail to perform the intended function, as a result of:
  - (i) dilapidation, deterioration or decay;
  - (ii) faulty construction;
  - (iii) the removal, movement or instability of any portion of the ground necessary for the purpose of supporting such building;
  - (iv) the deterioration, decay or inadequacy of its foundation; or
  - (v) any other cause;
- (g) the building exclusive of the foundation, shows 33 percent or more damage or deterioration of any supporting member or 50 percent damage or deterioration of its nonsupporting members;
- (h) any building has in any nonsupporting part, member or portion less than 50 percent, or in any supporting part, member or portion less than 66 percent of the
  - (i) strength, or
  - (ii) *fire-resisting* requirements; and
- (i) a building because of inadequate maintenance, dilapidation, decay, damage, faulty construction or arrangement, inadequate light, air or sanitation facilities, or otherwise, is likely to cause sickness or disease.

---

NATIONAL  
BUILDING  
CODE  
2000

DWELLINGS AND OUTBUILDINGS (CLASS 1 AND 10)

SECTION **DC**

---

## **FIRE RESISTANCE**

---

**Performance Requirements**  
**Deemed-to-Satisfy Provisions**

**DC1**    **Fire Resistance and Stability**

---

---

# CONTENTS

## PERFORMANCE REQUIREMENTS

### DEEMED-TO-SATISFY PROVISIONS

Part		Part	
<b>DC1</b>	<b>Fire Resistance and Stability</b>		
DC1.1	External walls of Class 1 buildings	DC1.5	Exceptions
DC1.2	Class 1 buildings: Construction of external walls	DC1.6	Common walls
DC1.3	Class 10a building: External walls	DC1.7	Separating floors
DC1.4	Allowable encroachments	DC1.8	Sarking-type materials

---

---

## PERFORMANCE REQUIREMENTS

### OBJECTIVES

**DCP1** A Class 1 or Class 10 building must be so designed and constructed that the following objectives are fulfilled:

- (a) it is protected from fire in any other building; and
- (b) materials used in the construction be such that if there is a fire in the building –
  - (i) the spread of fire and the generation of smoke and toxic gases will be minimised;
  - (ii) stability will be maintained for a period at least sufficient for the occupants to escape and to ensure the safety of fire-fighters; and
  - (iii) there will be little risk of collapse onto adjoining property.

### REQUIRED PERFORMANCE

**DCP1.1** *External walls* of Class 1 buildings, located within 1.5 m of the allotment boundary or 3 m from other buildings than of Class 10 (a) on the same allotment must –

- (a) remain stable and not allow the passage of destructive heat, flames, smoke or gases through them for an hour, in the event of a fire; and
- (b) not allow the passage of flames, smoke or gases through *windows* for an hour and such *windows* must not be openable.

**DCP1.2** The *external wall* of a Class 10 (a) building which is less than 1 m away from the allotment boundary other than with a road alignment or public space must not be *combustible*.

**DCP1.3** A *common wall* must –

- (a) if it separates a Class 1 building from any Class other than 10 (a), remain stable and prevent the passage of destructive heat, flames, smoke or gases for an hour, in the event of a fire;
- (b) if it separates a Class 1 building from a Class 10 (a) building on different allotment be not *combustible*.

**DCP1.4** The underside of a floor separating 2 *sole-occupancy units* each being a separate domicile must not be *combustible*.

**DCP1.5** Any *sarking-type* material used in a Class 1 building must have a *flammability index* of less than 5.

---

## DEEMED-TO-SATIFY PROVISIONS

### FIRE RESISTANCE AND STABILITY

#### DC1.1 External walls of Class 1 buildings

Except as permitted by Clause DC1.4 or CD1.5, an *external wall* of a Class 1 building, and any openings in that wall, must comply with clause DC1.2 if-

- (a) the wall is set back less than 1.5 m from an allotment boundary other than the boundary adjoining a road alignment or other public space; or
- (b) the wall is less than 3.0 m from another building on the same allotment other than a Class 10 building.

#### DC1.2 Class 1 buildings: Construction of external walls.

- (a) *External walls* referred to in Clause DC1.1 must have a FRL of not less than 60/60/60.
- (b) Openings in *external walls* referred to in Clause DC1.1 must-
  - (i) be protected with fire *windows* or glass block or other construction with a FRL of at least -/60/-; and
  - (ii) not be fitted with openable *windows*.

#### DC1.3 Class 10a buildings: External walls

An *external wall* of a Class 10a building other than an *open garage* must be of *non-combustible* construction or lined externally with *non-combustible* material if it is set back less than 1.5 m from the allotment boundary other than with a road alignment or public space.

#### DC1.4 Allowable encroachments

The distance from an allotment boundary or between buildings must be the shortest distance measured from the outermost point of the building or buildings concerned, except that-

- (a) fascia, gutters, downpipes, *non-combustible* eaves lining, and the like;
- (b) masonry chimney backs, flues, pipes, cooling or heating appliances or other services;
- (c) light fittings, electricity or gas meters, aerials or antennae;
- (d) pergolas or sun blinds; and
- (e) unroofed terraces, landings, steps or ramps, not more than 1 m in height,

may encroach into that distance if thereby the distance to the boundary is not reduced to less than 1 m nor the distance between the buildings to less than 1.5 m.

#### DC1.5 Exceptions

Clause DC1.1 does not apply to-

- (a) an *external wall* that previously complied with this Part and is re clad, if the recladding does not reduce the distance to the boundary or building by more than 150 mm; or



---

(b) an *open garage*.

#### **DC1.6 Common walls**

A *common wall* must-

- (a) be of masonry or concrete, or be fully lined with *fire-protective covering* and extend to the underside of a *non-combustible* roof or not less than 450 mm above a roof with a *combustible* lining;
- (b) have a FRL of not less than 60/60/60 if it separates Class 1 buildings, or a Class 1 building and a Class 10 (a) building, on different allotments; or
- (c) be lined with a *non-combustible* material if it separates Class 10a buildings on different allotments.

#### **DC1.7 Separating floors**

The underside of a floor separating *sole-occupancy units*, each being a separate domicile and located one above the other, must be lined with material with a FRL of not less than 30/30/30.

#### **DC1.8 Sarking-type materials**

Any *sarking-type material* used in a Class 1 building must have a Flammability Index of not more than 5.

DWELLINGS AND OUTBUILDINGS (CLASS 1 AND 10)

SECTION **DD**

---

**ACCESS AND EGRESS**

<p><b>Performance Requirements</b> <b>Deemed-to-Satisfy Provisions</b></p>
--

<p>DD1 Construction of Exits</p>
----------------------------------

---

## CONTENTS

### PERFORMANCE REQUIREMENTS

### DEEMED-TO-SATIFY PROVISIONS

Part

**DD1 Construction of Exits**

DD1.1 Treads and risers

DD1.2 Curved stairs

DD1.3 Balustrades

Part

DD1.4 Parapets on flat roofs

DD1.5 Number of exits

DD1.6 Ramp in exits

DD1.7 Dimensions of exits

---

## PERFORMANCE REQUIREMENTS

### OBJECTIVES AND REQUIRED PERFORMANCE

**DDP 1** A Class 1 or 10 (a) building must be so designed and constructed that the following are fulfilled:

- (a) Stairways, ramps and passageways must be such as to provide safe passage for the users of the building.
- (b) Stairways, ramps, floors and balconies, and any roof to which people normally have access, must have bounding walls, balustrades or other

barriers where necessary to protect users from the risk of falling.

- (c) Stairways must provide safe and reasonably comfortable dimensions for goings and risers. In any case the *pitch* of the stairway must be maintained within limits of 23° and 42°.
  - (d) If any ramp is used the slope must not exceed 1:8.
  - (e) A Class 1 building must have provision for fast *exit* during any emergency.
-

## DEEMED-TO-SATISFY PROVISIONS

### CONSTRUCTION OF EXITS

#### DD1.1 Treads and risers

- (a) A stairway must be suitable to provide safe passage in relation to the nature, volumes and frequency of likely usage.
- (b) A stairway in any building satisfies (a) if it has:
- (i) not more than 18 risers in each flight;
  - (ii) going and riser dimensions in accordance with Figure DD1.1 and Table DD1.1 that are constant throughout each flight;
  - (iii) risers which do not have any openings that would allow a 100 mm sphere to pass through between the treads;
  - (iv) treads which have a non-slip finish or a suitable non-skid strip near the edge of the nosing;
  - (v) treads of solid construction (not mesh or other perforated material) if the stairway connects more than 3 storeys; and
  - (vi) the tread must not exceed the going by more than 20 mm.

#### DD1.2 Curved stairs

Curved stairs must comply with the relevant requirements of DD1.1 as well as the following:

- (a) For the purposes of satisfying Table DD1.1 the going must be measured:
- (i) along half way across the width of the stair where the clear width is less than 900 mm; and
  - (ii) 300 mm from each side of the stair where the clear width is 900 mm or more.
- (b) All steps must have the same uniform taper.
- (c) The going at the narrow end of the steps must be not less than 75 mm.
- (d) Winders are not permitted.

#### DD1.3 Balustrades

- (a) A continuous balustrade must be provided along the side of any stairway or ramp, or any corridor, hallway, balcony, bridge or the like, if –
- (i) it is not bounded by a wall; and
  - (ii) the change in level is more than 1m

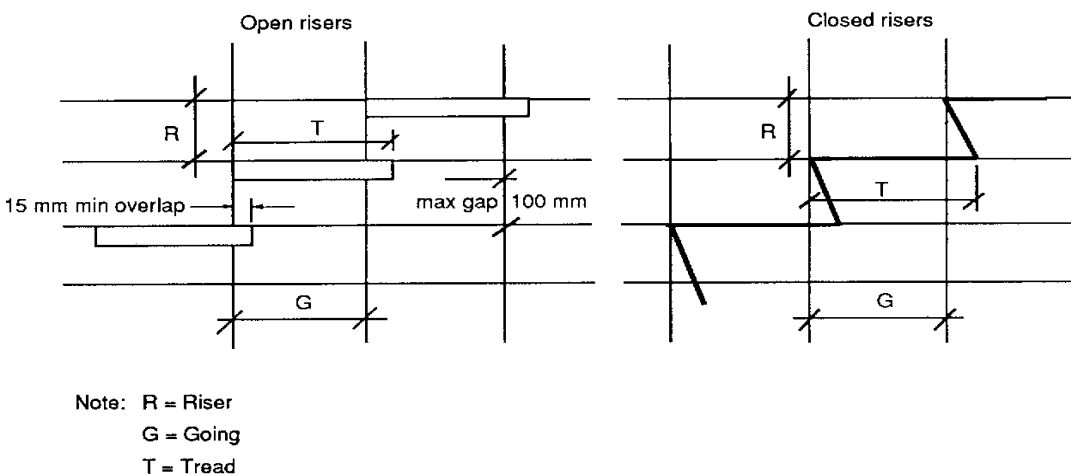

FIGURE DD1.1 MEASUREMENT OF RISER GOING AND TREAD

**TABLE DD1.1  
RISER DIMENSIONS (mm) TO MATCH GOING**

Pitch	GOING (mm)											
	230	240	250	260	270	280	290	300	310	320	330	
42°												
41°	200											
40°	192	200										
39°	186	194	200									
38°	180	187	195	200								
37°	173	181	188	196	200							
36°	167	174	182	188	196	200						
35°	161	168	175	182	189	195	200					
34°	155	162	168	175	182	188	195	200				
33°	149	156	162	169	175	181	188	195	200			
32°		144	156	162	168	174	181	187	194	200		
31°			150	156	162	167	174	180	186	192	198	
30°				150	156	161	167	173	179	185	190	
29°					150	155	161	167	173	179	183	
28°						150	155	160	165	170	175	
27°							148	153	158	163	168	
26°								146	151	156	161	
25°										149	154	
24°												147

**Note:**

Actual riser dimension may be selected to suit the inter landing height. However the value of the riser dimension must not be outside the maximum or minimum dimensions shown for each value of going.

---

(b) A balustrade must prevent, as far as practicable –

- (i) children climbing over or through it;
- (ii) persons accidentally falling from the floor; and
- (iii) objects which might strike a person at a lower level accidentally falling from the floor surface.

(c) At balconies a balustrade satisfies (b) if –

- (i) it has a height of not less than 930 mm above the balcony floor;
- (ii) the space between balusters or the width of any opening in the balustrade is not more than 100 mm except where the space between the rails or the height of the opening is not more than 100 mm;
- (iii) all parts of the balustrade more than 150 mm and less than 760 mm from the floor or nosings are vertical or otherwise do not provide a toe-hold; and
- (iv) it does not have any openings more than 100 mm wide within 150 mm of the floor level.

(d) In stairways and ramps (including access bridges and landings) a balustrade satisfies (b) if –

- (i) it has a height of not less than 865 mm above the nosing of the stair treads and the floor of the landing, balcony, corridor, hallway, access bridge or the like;
- (ii) the space between balusters or the width of any opening in the balustrade (including any openable window or panel) is not more than 100 mm except

where the space between rails or the height of the opening is not more than 100 mm; and

- (iii) all parts of the balustrade more than 150 mm and less than 760 mm from the floor or nosings are vertical or other wise do not provide a toe-hold.

#### **DD1.4 Parapets on flat roofs**

Where a flat roof or other elevated place has regular access a parapet or balustrade of not less than 1 m height above the surface of the roof or elevated place must be provided. The width of any opening in the parapet or balustrade must not exceed 100 mm.

#### **DD1.5 Number of exits**

Every Class 1 building must have two *exits*. At least one of these *exits* must provide easy means of egress in case of any emergency without security to the building. Such emergency *exits* may take the form of a trap door on an elevated floor or some such arrangement. *Windows* and other such opening used as emergency *exits* must have a minimum clear dimension of 560 mm and a minimum clear area of opening of 0.6 m<sup>2</sup>. The shutter must be capable of opening to 90° to the wall. The top of the *window* sill must be no more than 900 mm from the floor inside. The height of the *window* sill from the ground or floor outside must not exceed 1800 mm.

#### **DD1.6 Ramp in exits**

A ramp may be used in place of a stairway. The gradient of any such ramp must be no steeper than 1:8.

#### **DD1.7 Dimensions of exits**

The clear minimum width of a stairway or ramp must be 760 mm. The unobstructed height throughout must be not less than 2 m.

---

NATIONAL  
BUILDING  
CODE  
2000

DWELLINGS AND OUTBUILDINGS (CLASS 1 AND 10)

SECTION **DE**

---

**ELECTRICITY**

---

**Performance Requirements  
Deemed-to-Satisfy Provisions**

**DF1    Electricity Safety**

**DF2    Amenity**

---



---

# CONTENTS

## PERFORMANCE REQUIREMENTS

### DEEMED-TO-SATISFY PROVISIONS

Part

**DE1 Electrical Safety**

DE1.1 General Requirement

DE1.2 Plug Sockets

Part

**DE2 Amenity**

DE2.1 Light switch layout

---

## PERFORMANCE REQUIREMENTS

### OBJECTIVES

All electrical work associated with a Class 1 or 10 building must meet the following objectives –

#### DEP1 Electrical Safety

It must prevent electrocution, burns or fire.

#### DEP2 Amenity

It must satisfy the reasonable expectations of the occupants by ensuring that it is adequate for their intended use, both current and anticipated.

### REQUIRED REFORMANCE

#### DEP1.1 Electrical safety

The supply system must:

- (a) have suitable devices of adequate interruptive duty to automatically shut off the supply in the event of a fault or overload. Such devices must allow easy reinstatement of the supply after interruption;

- (b) have devices which are clearly identified and easily reached to isolate live parts from the incoming supply;
- (c) when the neutral of the supply is earthed, have socket outlet or plug – socket adaptor construction which would ensure that the live, neutral and earth conductors can only be connected to the corresponding live, neutral and earth conductors of the plug;
- (d) be adequately protected against damage arising from exposure to weather, water or excessive dampness mechanical loads and other such agents expected under normal conditions of use; and
- (e) ensure that the main switch is normally accessible only to the occupants.

#### DEP2.1 Amenity

The supply system must have an adequate number of plug sockets of minimum 10 Amperes capacity to serve the reasonable anticipated needs of the occupants.

---

## DEEMED-TO-SATISFY PROVISIONS

### ELECTRICAL SAFETY

#### DE1.1 General requirements

All electrical wiring and installations in or on any class 1 and 10 building must ensure safety from electric shock and fire. This requirement is satisfied if all electrical work associated with the building is done to comply with AS/NZS 3000 – Electrical installations – buildings, structures and premises (known as the SAA Wiring Rules) The capacity of the system must allow for the long term anticipated requirements of the occupants.

#### DE1.2 Plug sockets

Plug sockets must:

- (a) have their individual switch;
  - (b) be located so that
    - (i) cords need not be taken across doorways;
    - (ii) trailing cords do not have to cross circulation routes;
  - (c) not be located behind door-swings; and
  - (d) in the kitchen be located 250 mm above worktops at the back of benches or on a return wall where it exits.
-

---

## AMENITY

### DE2.1 Light switch layout

The layout of light switches must follow the main night time circulation routes such as from the entrance hall to the living area to the bed-rooms to the bathroom and toilet. Crossing any major space in the dark must be avoided. The switches must be located close to door openings.

---

---

NATIONAL  
BUILDING  
CODE  
2000

DWELLINGS AND OUTBUILDINGS (CLASS 1 AND 10)

SECTION **DF**

---

**HEALTH AND AMENITY**

---

**Performance Requirements  
Deemed-to-Satisfy Provisions**

- DF1 Damp and Weatherproofing**
  - DF2 Cooking and Sanitary Facilities**
  - DF3 Room Sizes and Heights**
  - DF4 Light and Ventilation**
  - DF5 Watersupply Plumbing**
  - DF6 Sanitary Plumbing and Drainage**
  - DF7 Roof Drainage**
-

---

## CONTENTS

### PERFORMANCE REQUIREMENTS

#### DEEMED-TO-SATISFY PROVISIONS

Part	Part
<b>DF1 Damp and Weatherproofing</b>	DF4.9 Airlocks
DF1.1 Site drainage	DF4.10 Sub-floor ventilation
DF1.2 Building on land subject to dampness	<b>DF5 Watersupply Plumbing</b>
DF1.3 Drainage of land external to building	DF5.1 General requirements
DF1.4 Weatherproofing of roofs and walls	DF5.2 Means of compliance
DF1.5 Pliable roof sarking	DF5.3 Pipes which are not easy to access
DF1.6 Water proofing of wet areas in buildings	DF5.4 Access to domestic-type water heaters
DF1.7 Damp-proof courses and mortars	DF5.5 Rainwater storage
DF1.8 Acceptable damp-proof courses	<b>DF6 Sanitary Plumbing and Drainage</b>
DF1.9 Damp-proofing of floors on the ground	DF6.1 General Requirements
<b>DF2 Cooking and Sanitary Facilities</b>	DF6.2 Means of compliance
DF2.1 Facilities required	DF6.3 Fixture unit ratings
<b>DF3 Room Sizes and Heights</b>	DF6.4 Trapping of fixtures and appliances
DF3.1 Height of rooms	DF6.5 Fixture discharge pipes
DF3.2 Reduced height permissible	DF6.6 Unvented branch drains
DF3.3 Ceiling fans	DF6.7 Venting
<b>DF4 Light and Ventilation</b>	DF6.8 Design of pipes and drains
DF4.1 Provision of natural light	DF6.9 Gully traps other than floor waste gullies
DF4.2 Methods and extent of natural lighting	DF6.10 Floor waste gullies
DF4.3 Natural light borrowed from adjoining room	DF6.11 Inspection openings
DF4.4 Artificial lighting	<b>DF7 Roof Drainage</b>
DF4.5 Ventilation of rooms	DF7.1 Design of roof gutters
DF4.6 Natural ventilation	DF7.2 Design of downpipes
DF4.7 Ventilation borrowed from adjoining room	DF7.3 Incompatible metals for gutters
DF4.8 Restriction on position of WCs and urinals	<b>Specification</b>
	Specification DF2.1 Latrines for Areas where there is no Water Supply
	Specification DF5.5 Rainwater Storage

---

## PERFORMANCE REQUIREMENTS

### DAMP AND WEATHERPROOFING

#### OBJECTIVES

**DFP1** The design and construction of a Class 1 building must meet the following objectives-

- (a) freedom from unhealthy and uncomfortable damp and wet conditions;
- (b) proper facilities for the preparation and cooking of food and the cleaning of utensils;
- (c) adequate facilities for personal washing and the washing of clothes;
- (d) hygienic toilet facilities with adequate privacy and which will not be a nuisance to anyone;
- (e) sufficient living space for privacy and comfort;
- (f) adequate light and ventilation consistent with the requirements of health hygiene and comfort;
- (g) where a public or private water supply exists, an appropriate safe and hygienic system of plumbing for the supply of water for domestic needs;
- (h) where a reticulated system of water supply is installed in the building, an appropriate system of drainage for the hygienic conveyance of sewage and waste water;
- (i) where a roof drainage system is provided, it must give reasonable protection against the overflow of rainwater into the building; and
- (j) unhealthy ponding of water in the allotment must not be allowed and the reaction of the building or any alteration to it must not adversely affect the drainage of other allotments or of any public land.

#### REQUIRED PERFORMANCE

##### DFP1.1 Damp and weatherproofing

Building must be so sited and suitable damp and weatherproofing provided where necessary to prevent-

- (a) moisture or damp affecting the stability of the building;

- (b) the creation of any unhealthy or dangerous condition;
- (c) damage or defacement from moisture present at the completion of construction;
- (d) causing undue damage to adjoining property; or
- (e) the accumulation of surface water against the building or beneath the floor.

##### DFP1.2 Cooking and sanitary facilities

Adequate cooking toilet and washing facilities must be provided for the occupants to allow reasonable comfort, hygiene and privacy.

##### DFP1.3 Room Sizes

The *floor area*, plan dimensions and ceiling heights of rooms and other spaces must be adequate for living purposes.

##### DFP1.4 Light and ventilation

The standard of light and ventilation within a building must be adequate for the occupants, having regard to health hygiene and comfort.

##### DFP1.5 Water supply plumbing

Plumbing for water supply must use materials which do not react with the water and thereby make it unsuitable for domestic use. Suitable precautions must be taken to ensure that unsafe or unhygienic materials have no chance of entering the supply system. The installation of hot water systems must not impair the safety of the users. All concealed and difficult-to-access plumbing work must be suitably protected so that there is no likelihood of damage and leakage. The plumbing must take into account the current and anticipated needs of the users and allow for the simultaneous use of the connected system by others. Where rainwater from the roof run off is the source of supply care must be exercised to ensure that there is no reasonable chance for the water to become contaminated. Allowance must be made for lean years of rainfall.

##### DFP1.6 Sanitary plumbing and drainage

Sanitary plumbing must be laid to self-cleansing grades consistent with their discharge loading, unless

---

other suitable arrangements are made to ensure that the system is kept free of the accretion of sewage and other waste matter. The size of drains and the layout of their connections must reasonably ensure the current and anticipated needs of the users. The connections to sanitary installations must ensure that foul gases are not allowed to produce unhygienic conditions nor create any nuisance to anyone and are suitably vented.

#### **DFP1.7 Roof drainage**

The roof drainage system must be capable of handling peak intensities of rainfall as follows:

- (a) Eaves gutters and downpipes – a 20 year return intensity.

- (b) Internal box gutters, valley gutters and downpipes – a 100 year return intensity.

Any known variation in rainfall intensity must be taken into account. Sufficient allowance must be made for the possibility of overflow into the building due to ripples and turbulence in the flowing water during cyclonic winds.

#### **DFP1.8 Site drainage**

The immediate site around the building must have suitable drainage so that no ponding results. Visible water must not be allowed to remain under or around for more than 1 hour after 10 minutes of maximum rainfall resulting from a storm with a return period of 5 years. Flood waters or waves resulting from a storm or cyclone with a return period of 30 years must not be allowed to enter a building.



---

## DEEMED-TO-SATISFY PROVISIONS

### DAMP AND WEATHERPROOFING

#### DF1.1 Site drainage

The construction of a site drainage system and the position and manner of discharge of a stormwater drain must not-

- (a) result in the entry of water into any building or other allotments;
- (b) affect the stability of any building; or
- (c) create any unhealthy or dangerous condition within or around any building.

#### DF1.2 Building on land subject to dampness

One or more of the following measures must be carried out if it is warranted by the dampness of the building *site*:

- (a) The subsoil must be adequately drained.
- (b) The ground under the building must be regraded or filled and provided with outlets to prevent accumulation of water.
- (c) The surface of the ground under the building must be covered with a suitable damp-resisting material.

#### DF1.3 Drainage of land external to building

A suitable system of drainage must be provided if paving, excavation or any other work on an allotment will cause undue interference with the existing drainage of rainwater falling on the allotment whether the existing drainage is natural or otherwise.

#### DF1.4 Weatherproofing of roofs and walls

Roofs and *external walls* must be constructed to prevent rain or dampness penetrating to the inner parts of a building.

#### DF1.5 Pliable roof sarking

Pliable roof *sarking-type* material used under roof or wall coverings must comply and be fixed in accordance with 4200.

#### DF1.6 Water proofing and wet areas in buildings

The following parts of a building must be impervious to water:

- (a) In any building – the floor surface or substrate in a shower enclosure, or within 1.5 m measured horizontally from a point vertically below the shower fitting, if there is no enclosure;
- (b) The wall surface or substrate –
  - (i) of a shower enclosure, or if the shower is not enclosed, within 1.5 m and exposed to a shower fitting, to a height of 1.8 m above the floor;
  - (ii) immediately adjacent or behind a bath, trough, basin, sink, or similar fixture, to a height of 300 mm above the fixture if it is within 75 mm of the wall.
- (c) The junction between the floor and wall if the wall and floor are *required* to be impervious to water.
- (d) The junction between the wall and fixture if the wall is *required* to be impervious to water.

#### DF1.7 Damp-proof course and mortars

Moisture from the ground must be prevented from reaching –

- (a) the lowest floor timbers and the walls above the lowest floor joists;
- (b) the walls above the damp-proof course; and
- (c) the underside of a suspended floor constructed of a material other than timber, and the supporting beams or girders.

#### DF1.8 Acceptable damp-proof courses

A damp-proof course must consist of –

- (a) a material that complies with AS/NZS 2904; or
- (b) suitable termite shield placed on piers; or
- (c) other suitable material.

---

**DF1.9 Damp-proofing of floors on the ground**

If a floor of a room is laid on the ground on filling moisture from the ground must be prevented from reaching the upper surface of the floor and adjacent walls by-

- (a) the insertion of a vapour barrier in accordance with AS 2870.1; or
  - (b) other suitable means.
-

## COOKING AND SANITARY FACILITIES

### DF2.1 Facilities required

Cooking and sanitary facilities must be provided as shown in Table DF2.1

<b>TABLE DF2.1 PROVISION OF COOKING AND SANITARY FACILITIES</b>	
MINIMUM FACILITIES REQUIRED	
In all cases	(a) facilities for the preparation and cooking of food, and for the cleaning of utensils.
Where there is piped water supply to the kitchen and ablution areas	(b) a kitchen sink in a kitchen (c) a shower or other adequate personal washing facilities (d) clothes washing facilities. (e) a closet pan and facilities for washing hands
Where there is piped water supply only to a tap in the kitchen or up to a stand-pipe in the vicinity of the building or where there is no piped water supply	(f) a paved raised platform with a paved area and drain around it. (g) a suitable type of privy as per Specification DF2.1.
<b>NOTE:</b>  (i) If any of these facilities are detached from the main building, they must be set aside for the exclusive use of the occupants of the building.  (ii) Where the layout allows it, facilities in (c), (d) and (e) can be in the same room.	

---

## ROOM SIZES AND HEIGHTS

### DF3.1 Height of rooms

Minimum heights below the ceiling and any framing excluding minor projections such as cornices, are:

- (i) *habitable room* – average 2.4 m and minimum of 2.1 m; and
- (ii) bathroom, shower room, water closet, laundry, pantry, or the like – 2.1 m.

### DF3.2 Reduced height permissible

These heights may be reduced if the reduction does not unduly interfere with the proper functioning of the room.

### DF3.3 Ceiling fans

Ceiling fans and other such appliances must be at a minimum vertical clearance of 2.1 m.

---

---

## LIGHT AND VENTILATION

### DF4.1 Provision of natural light

Natural lighting must be provided to all *habitable* rooms.

### DF4.2 Methods and extent of natural lighting

Direct natural lighting must be provided by *windows* that –

- (a) have an aggregate light transmitting area measured excluding framing members, glazing bars or other obstructions of not less than 10% of the *floor* area of the room;
- (b) face-
  - (i) a court or other space open to the sky; or
  - (ii) an open verandah, open carport, or the like;
- (c) are not less than a horizontal distance of 1m from any boundary of an adjoining allotment that they face.

### DF4.3 Natural light borrowed from adjoining room

Natural lighting to a room may come through a glazed panel or opening from an adjoining room (including an enclosed verandah) if-

- (a) the glazed panel or opening has an area of not less than 10% of the *floor area* of the room to which it provides light;
- (b) the adjoining room has *windows* with an aggregate light transmitting area of not less than 10% of the combined *floor areas* of both rooms,

and the areas specified in (a) and (b) may be reduced as appropriate if direct natural light is provided from another source.

### DF4.4 Artificial light

Artificial lighting must be provided to sanitary compartments, bathrooms, shower rooms, airlock and laundries, if natural lighting of a standard equivalent to that *required* by DF4.2 is not available and the periods of occupation, or use of the room or space will create undue hazard to occupants seeking egress in an emergency.

### DF4.5 Ventilation of rooms

A *habitable room*, *sanitary compartment*, bathroom, shower room, laundry and any other room occupied by a person for any purpose must be provided with natural ventilation complying with DF4.6. Where it is not practical to provide natural ventilation for any *sanitary compartment*, bathroom, shower or laundry, it is permissible to substitute natural ventilation with a mechanical ventilation system. In such a case the system must satisfy the requirements of AS1668 – 2.

### DF4.6 Natural ventilation

*Required* natural ventilation must be provided by permanent *windows*, openings, doors or other devices-

- (a) with an aggregate opening or openable size not less than 10% of the *floor area* of the room *required* to be ventilated; and
- (b) which open to –
  - (i) a court, or space open to the sky; or
  - (ii) an open verandah, open carport, or the like.

### DF4.7 Ventilation borrowed from adjoining room

Natural ventilation to a room may come through a *window*, opening, ventilating door or other device from an adjoining room (including an enclosed verandah) if-

- (i) the room to be ventilated or from which ventilation is borrowed is not a *sanitary compartment*;
- (ii) ventilation is not borrowed from one bedroom to another or between a bedroom and the kitchen;
- (iii) the *window*, opening, door or other device has a ventilating area of not less than 10% of the *floor area* of the room to be ventilated; and
- (iv) the adjoining room has a window, opening, door or other device with a ventilating area of not less than 10% of the combined *floor areas* of both rooms.

NOTE: the ventilating areas specified may be reduced as appropriate if direct natural ventilation is provided from another source.

---

**DF4.8 Restriction on position of WCs and urinals**

A room containing a closet pan or urinal must not open directly into-

- (a) a kitchen; or
- (b) a room for storage or consumption of food, except if it is in a building containing only one *habitable room*.

**DF4.9 Airlock**

If a room containing a closet pan or urinal is prohibited under DF4.8 from opening directly to another room –

- (i) access must be by an airlock, hallway or other room; or
- (ii) the room containing the closet pan or urinal must be provided with an exhaust fan.

**DF4.10 Sub-floor ventilation**

- (a) Suitable provision must be made to prevent undue deterioration of the lowest floor of a building because of dampness, other conditions on the allotment or the design of the building.
- (b) The following would satisfy the requirements of (a) –

- (i) where timber is used, the floor framing must be suspended with an absolute minimum of 250 mm and an average minimum of 400 mm clearance from the ground underneath, to the floor and the immediate surrounds of the building. The average clearance must be determined as the average of the clearance at the corner of a 3 m square grid covering the building plan. Subfloor ventilation must be provided with ventilation openings totaling not less than 3% of the peripheral vertical area between the ground and the boundary of the floor. These openings are to be spaced uniformly at not more than 1.8 m apart.

- (ii) where other than timber is used the following must be provided –
  - Subfloor ventilation if the floor is suspended;
  - an impervious cover over the ground surface beneath the building; or
  - the floor members suitably treated.

---

## WATER SUPPLY PLUMBING

### DF5.1 General requirements

The plumbing work for water supply must ensure-

- (a) the appropriateness of the materials and products used;
- (b) the correct sizing of water services for the intended use;
- (c) the control of cross-connections and prevention of backflow;
- (d) adequate care in the installation of the services;
- (e) suitable provision of main and subsidiary storage as *required*;
- (f) adequate connections to sanitary services without endangering health and hygiene; and
- (g) that the installation of hot water systems provide safe and adequate service.

### DF5.2 Means of compliance

The requirements of DF5.1 are satisfied if all plumbing for water supply is carried out to the relevant provisions of –

- (a) AS 3500 – Part 1 for cold water service; and
- (b) AS 3500 – Part 4 for hot water service.

### DF5.3 Pipes which are not easy to access

Particular attention is drawn to the provisions in AS 3500- Parts 1 and 4 which prohibit the installation of pipes and fittings of certain materials in locations which are concealed or difficult to access. These

include pipe made of ABS, galvanised steel, polybutylene and UPVC. Pipes and fittings made of copper, copper alloy, stainless steel, ductile iron, cast iron and polyethylene when used in concealed or difficult to access locations must follow the special precautions specified in AS 3500 – Part 1 and 4.

### DF5.4 Access to domestic-type water heaters

- (a) A household water heater which is installed in a building must-
  - (i) be supported on construction sufficient to carry its full capacity weight and any possible wind or earthquake loads;
  - (ii) be positioned to enable adequate access for operation, maintenance and removal; and
  - (iii) provide suitably for any overflow, especially if installed in a concealed location.
- (b) AS 3500 – Part 4 is the relevant standard for the installation of a household water heater.

### DF5.5 Rainwater storage

Where rainwater is collected and stored, the storage and distribution must reasonably ensure that the water is not contaminated by unsafe or unsuitable materials. The capacity of the catchment and storage must be adequate to provide a continued supply of water during years of low rainfall.

The details given in Specification DF5.5 meet the requirements of this clause.

## SANITARY PLUMBING AND DRAINAGE

### DF6.1 General Requirements

Sanitary plumbing and drainage must ensure –

- (a) the appropriateness of the products and materials used;
- (b) the correct sizing of drainage services for the intended use;
- (c) adequate care in the installation of the services including the provision of appropriate grades; and
- (d) that foul gases are not allowed to produce unhygienic conditions or any nuisance to anyone.

### NF6.1.1 Specific requirements

Sanitation facilities must ensure-

- (a) no discharge of wastewater of any kind to surface water;
- (b) no discharge to a soil surface that is less than 2.5 metres above maximum groundwater level;
- (c) the maximum design loading to a soil surface shall not exceed:
  - 35mm per day for septic tank effluent.
  - 70mm per day for secondary or better treated effluent.
- (d) the effluent distribution system shall achieve a uniform application at or less than the maximum design loading rate.
- (e) system chosen is consistent with Figure DF6.1.3

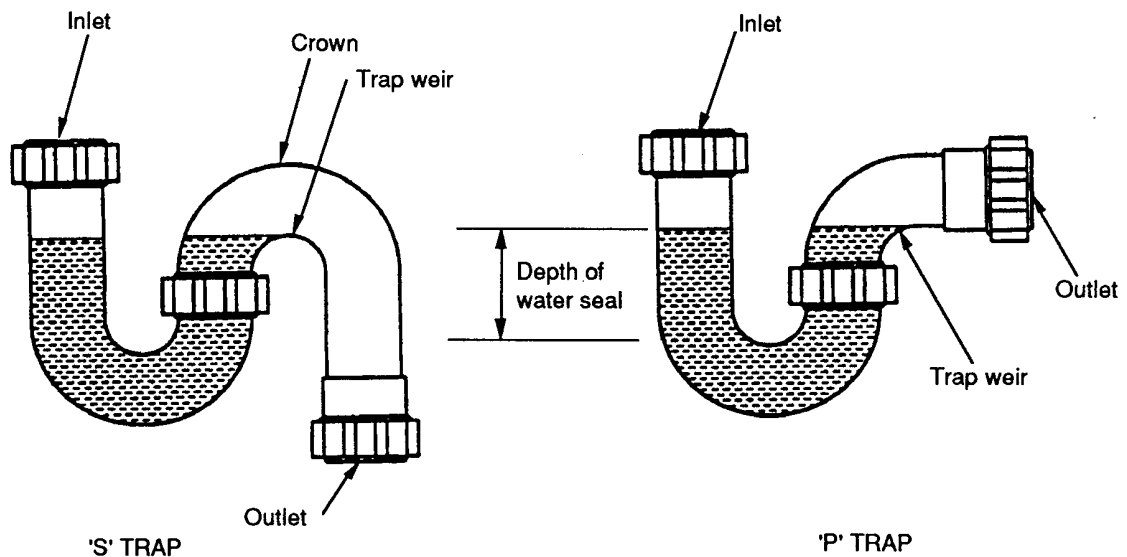

FIGURE DF6.1.2 EXAMPLES OF FIXTURE TRAPS



### DF6.1.2 Some common terms

Apart from the defined terms given in A1.1 the following terms used in this Section are explained:

#### (a) Nominal size (DN)

While converting to metric dimension some manufacturers of pipe and fittings have used hard conversion whereas others have used soft conversion. For these and other reasons it is impractical to specify exact pipe and fitting dimensions. All pipes and fittings in this Section are therefore specified by their nominal size. This is indicated by the letters “DN” followed by a number.

Since this number is only an approximation of the actual size, it is not subject to exact measurement and must not be used in calculations. The nominal size is thus only a numerical designation of the size which is common to all components in a piping system (other than components such as steel tubes which are designated by their outside diameter and other components by their thread size). It is just a convenient round number for reference purposes and is only loosely related to the manufacturing dimensions.

#### (b) Trap

A trap is a device which retains a water seal for preventing the escape of sewer gases from sanitary plumbing. Figure DF6.1.2 shows two common types of fixture traps. There are also traps integral with gullies, water closet pan etc.

The water seal can be broken by self-siphonage or induced siphonage as well as by positive pressure of the gases breaking through the seal. It is also possible for the seal to be dried out by prolonged non-use of the associated part of the system.

The best means of preventing the loss of the seal by siphonage or by positive pressure is to vent the trap to the outside air.

#### (c) Fixture discharge pipe

This is the discharge pipe to which any single sanitary fixture is connected.

#### (d) Gullies

A gully is an assembly used for providing a water seal when handling the discharge from only *waste fixture* and not any *soil fixture*. The water seal prevents the escape of foul gases into the

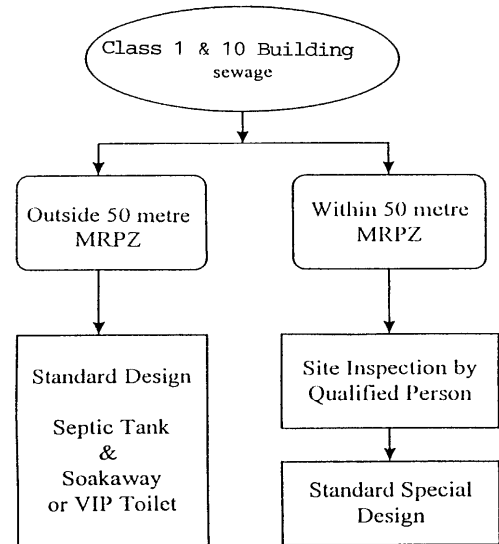

MRPZ = Marine and River Protection Zone

FIG. DF 6.1.3 DECISION MATRIX

building or into the atmosphere in the vicinity of the assembly.

It is a disconnector gully when it provides a separation through the water seal, between the discharge from *waste fixtures* and the rest of the sanitary system.

A floor waste gully is a disconnector gully used inside a building with a floor grating or waste outlet fitting on a riser pipe. Discharge pipes from *waste fixtures* may also connect to a floor waste gully.

An overflow relief gully functions as a self-cleaning trap and is provided with a loosely fitted grating. This allows for the relief of any possible surcharge or over flow from the *drain*. The riser of the gully may have inlets for discharge from *waste fixtures*.

### DF6.2 Means of compliance

The requirement of DF 6.1.1 are satisfied if all sanitary plumbing and drainage works are carried out to the relevant provisions of AS 3500 – Part 2 – Sanitary plumbing and sanitary drainage, as well as this part of the Code.

### DF6.3 Fixture unit ratings

In the design of discharge pipes and *drains* the *fixture unit* rating shown in Table DF6.3 must be

used. For the fixture listed in the Table the maximum unvented length of the associated fixture discharge pipe must not exceed 2.5 m except that this may be 6 m for a water closet pan with a DN 100 trap and discharge pipe. The

length of the pipe is measured along the centre line from the weir of the trap to the point of connection to a graded discharge pipe, *drain*, *stack* or other drainage trap.

**TABLE DF6.3  
FIXTURE UNIT RATINGS**

FIXTURE	Nominal size of trap outlet and fixture discharge pipe	Fixture unit Rating
Basin	DN30 or DN40	1
Bath (with or without shower)	DN40	4
Bidet	DN40	1
❖ Clothes washing machine	DN40	5
❖ Dishwashing machine	DN40	3
Floor waste gully		0
- without fixture	DN50	as per fixture rating
- with fixture	DN40 or DN 50	
Laundry trough	DN40 or DN50	5
Shower	DN40 or DN 50	2
Sink		
- less than 45 litres	DN40	2
- more than 45 litres	DN50	3
Water closet pan	DN80 or DN100	5
❖ (i) When a clothes washing machine connects to a trough trap, only the trough unit fixture rating is considered. (ii) When a dishwashing machine connect to a sink trap only the sink <i>fixture unit</i> rating is considered.		

#### DF6.4 Trapping of fixtures and appliances

**DF6.4.1** The discharge from all sanitary fixtures and appliances must pass through traps before entering the *drain*, *soil pipe* or *waste pipe*. The fixture trap must retain a water seal of:

- (a) 50 mm for traps of size DN50 or less
- (b) 75 mm for traps of size greater than DN50

The traps must be located as close as possible to the fixture and not farther than 600 mm from the fixture outlet, except in case of permitted fixture pairs and floor waste gullies.

**DF6.4.2** The following fixture may be connected in pairs to a single fixture trap:

- (a) Wash basins
- (b) Sinks
- (c) Laundry troughs
- (d) Showers

The fixture pairs must be connected so that the centre to centre distance between their outlets is not more than 1.2 m.

#### DF6.5 Fixture discharge pipes

##### DF6.5.1 Minimum grades

Discharge pipe must be laid to the minimum grade shown in Table DF6.5.1

TABLE DF6.5.1 MINIMUM GRADES OF DISCHARGE PIPES	
Nominal size	Minimum grade
DN30	1 in 30
DN40	1 in 40
DN65	1 in 40
DN80	1 in 60
DN100	1 in 60

### DF6.5.2 Connections

The connections of any fixture discharge pipe to a graded discharge pipe or between two graded discharge pipes must be made as follows:

- (a) With 45° or *sweep junction* fittings;
- (b) Where the pipes are of different sizes-
  - (i) the soffits of both must be in continuous alignment, and
  - (ii) where an unequal junction fitting is used, the soffit of the branch pipe must be at the same level or higher than the soffit of the pipe to which it connects; and
- (c) The level of the trap or floor waste gully weir must be at a higher level than the soffit of the graded discharge pipe to which it connects.

### DF6.5.3 Cleaning eyes

Fixture discharge pipes must have accessible cleaning eyes at all bends.

### DF6.6 Unvented branch drains

Where the risk of escape of dangerous and unpleasant gases into occupied premises is minimal the venting of branch *drains* is not *required*. However all of the limitations given in the following sub-clauses and illustrated in figure DF6.6 must be met in such cases. (For limitation of length of fixture discharge pipes, see DF6.3)

#### DF6.6.1 Limitations on location or nature of connection

- (a) The connection of any unvented branch *drain* to a vented *drain* must be located at the ground

floor level and the vented *drain* installed on grade below or above ground;

- (b) In the case of an unvented *drain* receiving discharge from only *waste fixtures*, it must connect to a gully;
- (c) An unvented *drain* other than in (b) must connect to a disconnector gully; or
- (d) The connection must be from a discharge pipe serving a single fixture and the length of the discharge pipe is –
  - (i) less than 3.5 m when serving a *waste fixture*; or
  - (ii) less than 3.0 m when serving a *soil fixture*.

#### DF6.6.2 Limitations on size, length and bends

- (a) The size of any unvented branch *drain* must comply with the limitations given in Table DF6.6.2

TABLE DF6.6.2 SIZE OF UNVENTED BRANCH DRAINS	
Nominal size	Maximum sum of <i>fixture unit</i> loadings discharging into the branch <i>drain</i>
DN65	5 (but not from a water closet pan) or 8 from one floor waste gully
DN80	12 (no more than 1 water closet pan connected)
DN100	30 (no more than 2 water closet pan connected)

- (b) The length of an unvented branch *drain* together with that of the fixture discharge pipe must not exceed –
  - (i) 8.5 m from the weir of the fixture trap;
  - (ii) 10 m to a disconnector gully; and
  - (iii) 2.5 m from the reducer to the weir of the trap, where the fixture discharge pipe is of smaller size than unvented branch *drain*.

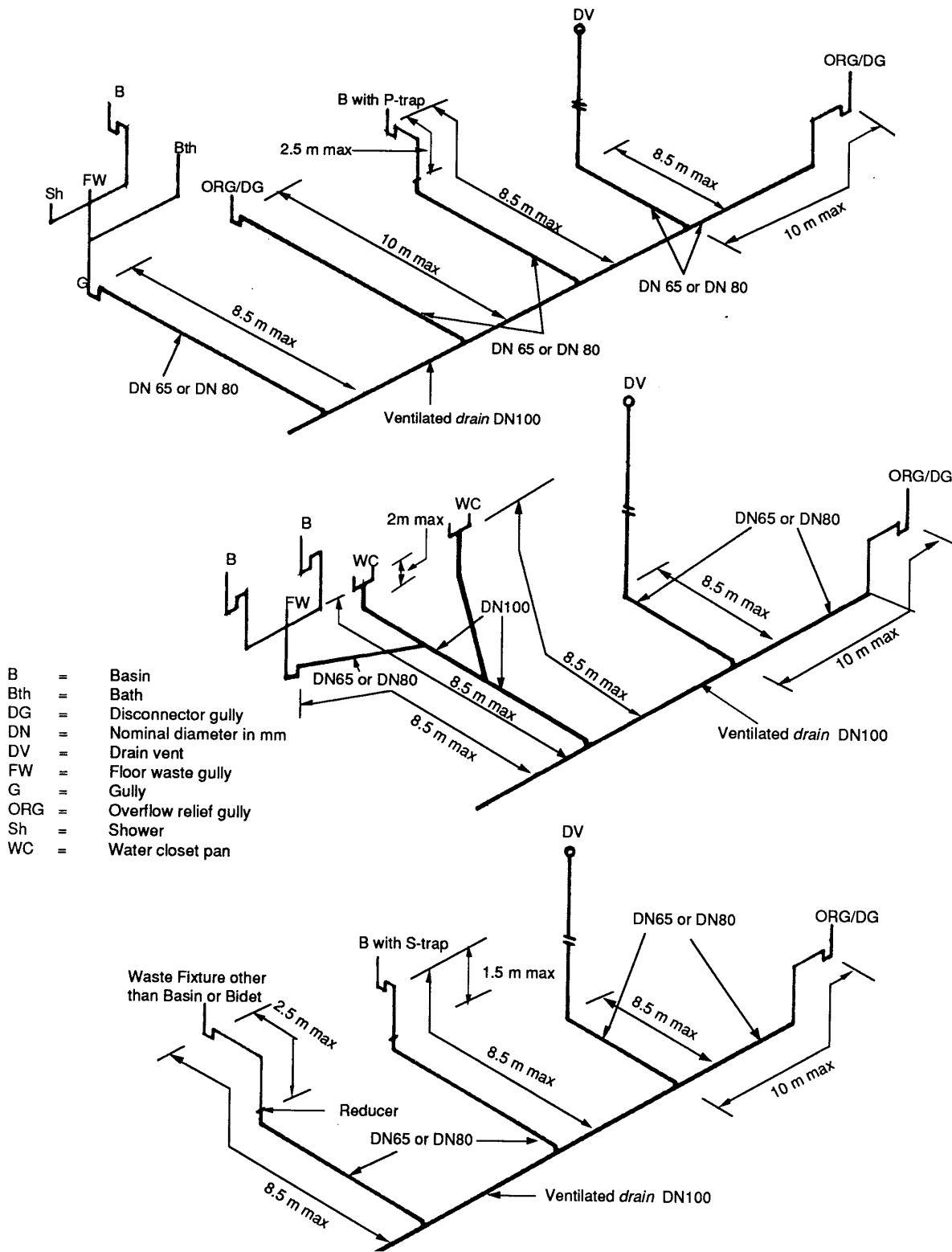

FIGURE DF6.6 LIMITATIONS ON UNVENTED BRANCH DRAINS

(c) The maximum vertical drop from the crown of the trap to the top of the vented *drain* to which the unvented branch *drain* connects must not exceed-

- (i) 1.5 m in the case of basins and bidets; and
- (ii) 2.5 m in the case of all other fixtures.

(d) The total combined number of long bends in a fixture discharge pipe and branch *drain*, up to the connection with a vented *drain* must be limited to:

- (i) 2 horizontal and 2 vertical with basins and bidets; and
- (ii) 2 horizontal and 3 vertical with all other fixtures. The distance between any adjacent horizontal bends must be not less than 300 mm and the vertical drop between two adjacent vertical bends must not exceed 2 m.

**Note:** A bend of 45° or less is not considered to be a bend for the purposes of this clause.

#### DF6.7 Venting

In order to prevent the escape of dangerous and unpleasant gases into occupied premises and to ensure that water seals in traps are not destroyed by siphonage, adequate venting must be provided for all fixture discharge pipes and *drains* except as allowed by DF6.6.

##### DF6.7.1 Trap vents

The minimum size of a trap vent must be related to the nominal size of the fixture trap as follows:

Size of fixture trap	Size of trap vent
DN30 or DN40	DN30
DN50 to DN100	DN40

Every trap vent must be extended upward at least 50 mm above the flood level rim of the fixture. This may be accomplished in one of the following ways:

- (a) As a vertical vent to open air, the outlet of which is no closer than 900 mm from any opening to the building;
- (b) On an ascending grade of at least 1:80 and then:
  - (i) as a vertical vent to the open air; or
  - (ii) to a connection with a vertical or branch vent

(c) Take the vent above the flood level rim of the fixture, then loop it down either vertically or on a downward grade of 1:80 and connect to a vertical or branch vent.

Trap vents must be located no closer than 75 mm and no farther than 1500 mm from the crown of the trap.

##### DF6.7.2 Drain vents

(a) General

Vents in *drains* must be provided –

- (i) at the upstream end of any *drain*;
- (ii) at the upstream end of any branch *drain* to which a fixture trap or floor waste gully is connected and if the distance from the weir of the trap to the vented *drain* exceeds 8.5 m;
- (iii) at the upstream end of any DN100 branch *drain* to which 3 or more water closet pans are connected; and
- (iv) at the upstream end of any DN80 branch *drain* to which no more than 2 water closet pans are connected.

(b) Location

The upstream vent of any *drain* must be connected-

- (i) at or close to the end of the *drain*; or
- (ii) at the vent extension of a stack located at or near the upstream end of the *drain*.

In either case it is permissible to have an unvented length of *drain* upstream of the vent connection if the unvented length complies with DF6.6.

(c) Size of vents

The minimum size of an upstream vent of any *drain* is DN50. Subject to this, the vent must be sized by using the ratings given in Table D6.7.2.

<b>TABLE DF6.7.2 SIZE AND RATING OF DRAIN VENTS</b>		
<i>Fixture units discharging into drain</i>	Vent rating	Vent size
1 to 10 (incl)	0.5	DN40
10(excl) to 30(incl)	1	DN50
30 (excl) to 175 (incl)	2	DN65
175 (excl) to 400 (incl)	3	DN80

When two or more vents are directly connected to the *drain* these can take the place of a single vent provided the sum of their ratings is not less than the rating *required* for venting the *drain*.

#### DF6.7.3 Termination of vents

- (a) Vent pipes from waste fixture discharging into disconnector gullies and from gullies located within buildings must be vented independently and not be interconnected to any other system vent. Such vents must terminate in the open air:
- (i) at a height of at least 50 mm above the overflow level of the associated fixture;
  - (ii) at least 900 mm from any opening to the building which is within a horizontal distance of 3 m from the vent; and
  - (iii) not less than 150 mm above its point of penetration through any roof covering.
- (b) Vents other than in (a) must terminate in the open air:
- (i) not less than 600 mm above any opening into any building which is within a horizontal distance of 3 m from the vent;
  - (ii) not less than 150 mm above its point of penetration through any roof covering;
  - (iii) not less than 3 m above any trafficable roof deck which is within a horizontal distance of 3 m from the vent;
  - (iv) not less than 2 m above or 600 mm below any chimney or similar opening within a horizontal distance of 3 m from the vent;

- (v) not less than 5 m from any air intake; and
- (vi) not less than 600 mm above any eave, coping or parapet which is within a horizontal distance of 600 mm from the vent.

### DF6.8 Design of pipes and drains

#### DF6.8.1 Sizing of discharge pipes

Discharge pipes must be not less than the size of the fixture traps to which they connected. The size must be determined from Table DF6.3 and take into consideration:

- (i) the sum of the *fixture unit* rating of all fixtures connected to the pipe;
- (ii) the proposed pipe gradient; and
- (iii) the maximum *fixture unit* loadings given in table DF6.8.1

<b>TABLE DF6.8.1 MAXIMUM FIXTURE UNIT LOADING FOR GRADED DISCHARGE PIPES</b>					
Grade	Nominal pipe size (mm)				
	40	50	65	80	100
1 in 20	6	15	51	65	376
1 in 30	5	10	29	39	248
1 in 40	4	8	21	27	182
1 in 50	x	x	x	20	142
1 in 60	x	x	x	16	115

#### Note

- (i) x indicates that the combination of pipe size and gradient is not permitted.
- (ii) Not more than 2 W.C pans are to be connected to any 80 mm pipe

#### DF6.8.2 Sizing of drains

The size of a vented *drain* must be determined by taking into account the total number of *fixture units* (obtained from Table DF6.3) discharging into the drain.

(a) Normal grades

The minimum normal grade of *drains* must be as given in Table DF6.8.2A

<b>TABLE DF6.8.2 A MINIMUM GRADIENT OF DRAINS</b>	
Nominal size (mm)	Minimum grade
80	1 in 60
100	1 in 60
125	1 in 80
150	1 in 100

(b) Maximum *fixture unit* loadings for vented *drains*.

The *fixture unit* loadings for vented *drains* must not exceed the values given in Table DF6.8.2 B for the size and grade of the *drain* shown.

<b>Table DF6.8.2 B MAXIMUM FIXTURE UNIT LOADINGS FOR VENTED DRAINS</b>				
Grade	Nominal pipe size (mm)			
	80	100	125	150
1 in 20	215	515	1450	2920
1 in 30	140	345	1040	2200
1 in 40	100	255	815	1790
1 in 50	76	205	665	1510
1 in 60	61	185	560	1310
1 in 70	50	140	485	1180
1 in 80	42	120	425	1040
1 in 90	x	x	380	935
1 in 100	x	x	x	855
1 in 120	x	x	x	725
1 in 150	x	x	x	595

Note: x indicates that the combination of nominal size and grade is not permitted.

(c) Reduced grades

Where the minimum grades given in Table DF6.8.2A are not achievable *drains* may be laid at the reduced grades given in Table DF6.8.2 C. In such a case the minimum *fixture unit* loadings given in the Table must be connected in advance of the top end of the reduced grade. Where even these reduced grades cannot be achieved provision must be made for regular and automatic flushing of the *drain*.

<b>TABLE DF6.8.2 C MINIMUM FIXTURE UNIT LOADINGS FOR REDUCED GRADE DRAINS</b>				
Reduced grade	Nominal pipe size (mm)			
	80	100	125	150
	<i>Maximum fixture unit loading</i>			
1 in 70	9	10	See Table DF6.8.2A	
1 in 80	10	18	"	"
1 in 90	x	x	27	"
1 in 100	x	x	38	"
1 in 120	x	x	x	75
1 in 150	x	x	x	160

**Note:** x means that the grade is not permitted unless special automatic flushing arrangements are made.

(d) A *drain* must not be oversized for the only purpose of using a lower gradient than the minimum gradient given in Table DF 6.8.2A. The size of a *drain* must not reduce in the direction of flow.

**DF6.8.3 Cover over drains**

(a) *Drains* must be protected against any mechanical damage and deformation resulting from the loads over them. Adequate cover must be provided to comply with Table DF6.8.3 unless exempted under (b).

TABLE DF6.8.3 MINIMUM DEPTH OF COVER DRAINS		
Location	Minimum cover from top of pipe socket to ground surface (mm)	
	Pipes of cast iron or ductile iron	Pipes of other materials
Household driveways	300	450
Other locations where no Vehicular loadings are expected	Nil	300

(b) Where it is not practical to provide the minimum cover to Table DF6.8.3, *drain* must be covered by a sandy overlay of at least 50 mm and provided with-

- (i) 75 mm thick concrete paving where light vehicular traffic may be expected; and
- (ii) 50 mm thick concrete paving at other locations where vehicular traffic is not expected.

The paving must be symmetric to the *drain* alignment and must have a minimum width equal to the depth of the base of the drain from the top of the paving plus 300 mm.

#### DF6.8.4 Drain close to buildings

##### (a) Drains under buildings

Where it cannot reasonably be avoided *drains* may be laid below ground under buildings in which case-

- (i) inspection openings must be provided at both ends of the *drain* adjacent to the building; and
- (ii) a minimum of 50 mm of sandy overlay provided over the pipe and below a reinforced concrete floor slab; or
- (iii) the *drain* must be protected from damage.

##### (b) Proximity of buildings

- (i) where a *drain* is to be laid parallel to a footing the excavation for it must clear a line at 45° from the extremity of the footing. (See Figure 6.8.4)
- (ii) where a *drain* crosses a strip footing, the angle of crossing must be not less than 45° and the top of the *drain* must clear the bottom of the footing by not less than 50 mm.

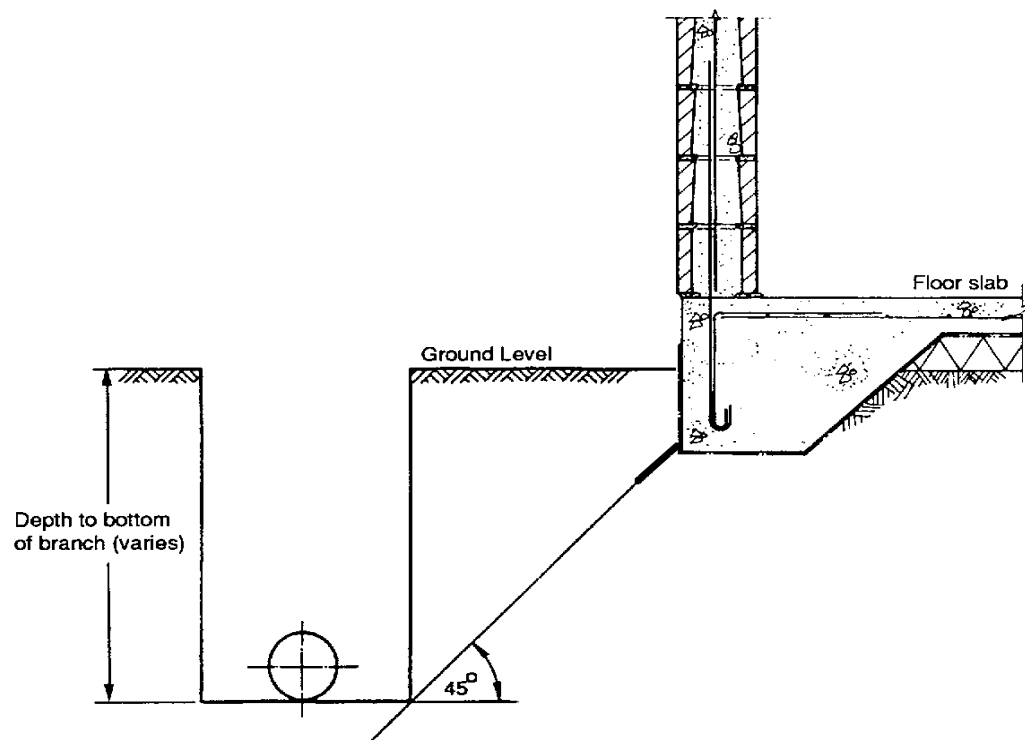

FIGURE DF6.8.4



(c) Building over *drains*

Where it is not practical to divert *drains* in order to avoid erecting building over them-

- (i) the restrictions listed in (a) and (b) must be observed; and
- (ii) other appropriate engineering precautions taken against damage.

**DF6.9 Gully traps other than floor waste gullies**

Gully traps may be used;

- (a) as overflow relief gullies to provide in the event of sewage surcharge; or
- (b) to provide disconnection between waste discharge and the remainder of the sewerage installation (disconnecter gullies).

**DF 6.9.1 General**

- (a) A gully must be installed such that-
  - (i) it is supported on a minimum 75 mm thickness of concrete of 17.5 Mpa grade; and
  - (ii) it is protected from damage at floor level by a concrete surround of minimum width and depth of 75 mm.
- (b) The following discharges must not be allowed into a gully;
  - (i) from any *soil fixture*; and
  - (ii) any rain water drainage from the roof or ground
- (c) The gully must have its water seal maintained from a *waste fixture* or floor waste gully. The maximum length of unvented waste pipe discharging into the gully must be 2.5 m from basins or bidets, 6 m from all other waste gullies and fixtures with DN50 or smaller pipes, and 8.5 m from floor waste gullies and fixtures with DN65 or larger pipes.

**DF6.9.2 Overflow relief gullies**

At least one overflow relief gully must be installed in a drain which is connected to a public sewer.

(a) Size

The size of the overflow relief gully is related to the size of the main *drain*. For a size of

main *drain* of DN80 the gully must also be DN80. For main *drains* of DN100 to 150 size, the gully must be DN100.

(b) Location

An overflow relief gully must be located within the property, external to the building, as far as practicable from the downstream end of the *drain*, and so that the top of the gully is accessible and positioned where any overflow can be easily noticed.

(c) Height

A minimum height of 150 mm must be kept between the top of the overflow gully riser and the lowest fixture connected to the *drain*. The point of measurement on fixtures is given in Table DF6.9.2.

<b>TABLE DF6.9.2 POINT OF MEASUREMENT OF FIXTURES FOR HEIGHT ABOVE OVERFLOW LEVEL OF GULLY</b>	
Fixture	Point of measurement
<i>Soil fixture</i> with integral trap	Level of water seal surface
Floor waste gully or shower outlet	Top surface level of grate
Other fixtures	Top surface level of fixture outlet

**DF6.9.3 Disconnecter gully traps**

Where installed within a building these must:

- (a) have the gully riser extend to floor level and be sealed with an airtight removable cover; and
- (b) a DN50 vent pipe must branch from the riser at an upward grade of not less than 1 in 80 and terminate with a grating at an external wall of the building above any likely flood level. Alternately the vent pipe can terminate as in DF6.7.3(a). No other fixture or appliance must be connected to the vent pipe.

**DF6.10 Floor waste gullies**

Floor waste gullies are functionally similar to fixture water traps. Shower outlets may be used as floor waste gullies. Any *waste fixture* may be connected to a floor waste gully. No trap is *required* other than for discharge outlets from basins. For other than basins the maximum length of the untrapped waste pipe must not exceed 1.2 m. If any of the fixtures is trapped the maximum length of the waste pipe is allowed to be up to 2.5m. However, the traps must not be vented. With the exception of allowed fixture pairs, each fixture must connect individually with the gully at a grade of not less than 1 in 40.

#### DF6.10.1 Size

The outlet size of a floor waste gully trap is based on the total *fixture units* of the fixtures and appliances discharging into it. The outlet size must be:

- (a) DN50 for a total *fixture unit* rating of 3 units or less; and
- (b) DN65 to DN100 for a total fixture unit rating of 10 or less.

A DN50 outlet and a DN50 riser may be used if the sole function of the gully is to dispose of water spillage and washdown water. All other gullies must have a minimum riser size of DN80 at floor level. A floor waste gully must have an accessible, removable grate.

#### DF6.10.2 Height of gully riser

The minimum height of the gully riser from the top of the water seal to the floor surface must comply with Table DF6.10.2. The maximum height must not exceed 600 mm.

Fixture connected	Minimum height from water seal to floor level (mm)	
	Waste pipe Entry at 88.5°	Waste pipe entry at 45°
Shower	150	100
Bath (only one)	250	200
Clothes washing machine	300	250
Other waste fixtures	250	150

#### DF6.10.3 Maintenance of water seal

At least one *waste fixture* must be connected to any floor waste gully in order to maintain the water seal.

For this reason the minimum depth of water seal must be 65 mm or the values in DF6.4.1, whichever is more.

### DF6.11 Inspection openings

#### DF6.11.1 General

Inspection openings comprise:

- (a) inspection branches or square *junctions*; or
- (b) inspection chambers.

#### DF6.11.2 Location

Inspection openings must be provided:

- (a) outside the building on each branch connecting one or more water closet pans;
- (b) at intervals of not more than 30 m;
- (c) downstream and upstream ends of any section of *drain* that passes under a building;
- (d) where any new section of *drain* is connected to an existing *drain*; and
- (e) at the connection to the public sewer.

Appropriate locations are illustrated in Figure DF6.11.2.

#### DF6.11.3 Size

- (a) The size of inspection branches or square junctions must be:
  - (i) the same size as the *drain* for drains up to DN150; and
  - (ii) not less than DN150 for larger *drains*.
- (b) The dimensions of inspection chambers must comply with Table DF6.11.3.

Minimum internal measurement (mm)			
Depth to floor of chamber	Rectangular		Circular
	Length	Width	Diameter
Less than 600	600	450	600
600 to 900	900	600	900
More than 900	1200	750	1050

---

#### DF6.11.4 Access for inspection branches and square junctions

Inspection branches and square *junctions* must be so located that it is possible to use them for inspection and for clearing obstructions in the associated sections of the *drain*. When located inside buildings inspection branches and square *junctions* must have their openings readily accessible. Such openings must have airtight removable caps or plugs with gaskets, rubber rings or such other accessories to maintain tightness. When the caps or plugs are removed for inspection/maintenance, the gasket/rubber ring must be replaced with a new one.

#### DF6.11.5 Construction of inspection chambers

(a) Where *required*

An inspection chamber is *required* where an inspection branch or square junction;

- (i) cannot accommodate all the convergent *drains*; or
- (ii) will not permit proper inspection or the clearing of obstructions.

(b) Conduits and channels

The conduits in inspection chambers may be open channels of size and shape equal to the associated *drains*. The floor in inspection chamber must slope at a grade of between 1 in 10 and 1 in 15 towards the channel. Any formed junction must have a centre line radius of not less than 300 mm. A fall of at least 30 mm must be provided in the invert of any channel that curves through 45° or more.

(c) Access opening

A circular or rectangular access opening of 530 mm minimum dimension and fitted with a removable watertight cover must be provided at surface level. The cover must have been designed and installed to take any likely load on it. Where the size of the inspection chamber is larger than the size of the access opening, the top section of the chamber may be suitably tapered. Where this is done the full dimensions of the chamber must be maintained for a height from the chamber floor of at least 1.5m, and the depth of the narrower shaft at the top not exceed 350 mm. The minimum dimension of the shaft except at the opening must be 600 mm.

(d) Access ladder

Where the depth of the chamber exceeds 1.2 m rungs or rung ladders must be provided to AS 1657.

(e) Materials of construction

Inspection chamber must have their base and walls of a minimum thickness of 150 mm and constructed of:

- (i) base-concrete; and
- (ii) walls – concrete or fully grouted concrete block masonry

The concrete must be of 20 MPa grade. The walls and base must be suitably reinforced if *required*. The channels may be formed of half sections of pipes and fittings. Any access rungs or ladder must be of galvanised steel. The cover and any frame to seal it must be of reinforced concrete or cast iron with safe lifting devices.

The walls and base of any inspection chamber must be cement rendered to a smooth finish. The render may contain a suitable water proofing agent to ensure a waterproof finish. Where there is any likelihood of seepage of sub-soil water into the manhole the external surfaces of the wall must be plastered to a water proof finish or a suitable water proofing agent added to the concrete in the walls and base.

(f) Inserts

The contact area between pipes or fittings and the walls formed around them, as well as holes broken into or formed in the walls of inspection chambers for insertion of pipes or fittings must be made water tight by –

- (i) the application of a suitable bonding agent around the pipes;
- (ii) caulking the annular space between the wall and the pipe or fitting with a stiff mix of one part cement and 2 parts sand;
- (iii) sealing with an epoxy based or other suitable sealant; or
- (iv) a combination of these methods.

#### DF6.11.6 Junctions

(a) *Junctions of drains* must –

- (i) be swept in the direction of flow or have an oblique *junction* fitting with an upstream angle of no more than 60°;

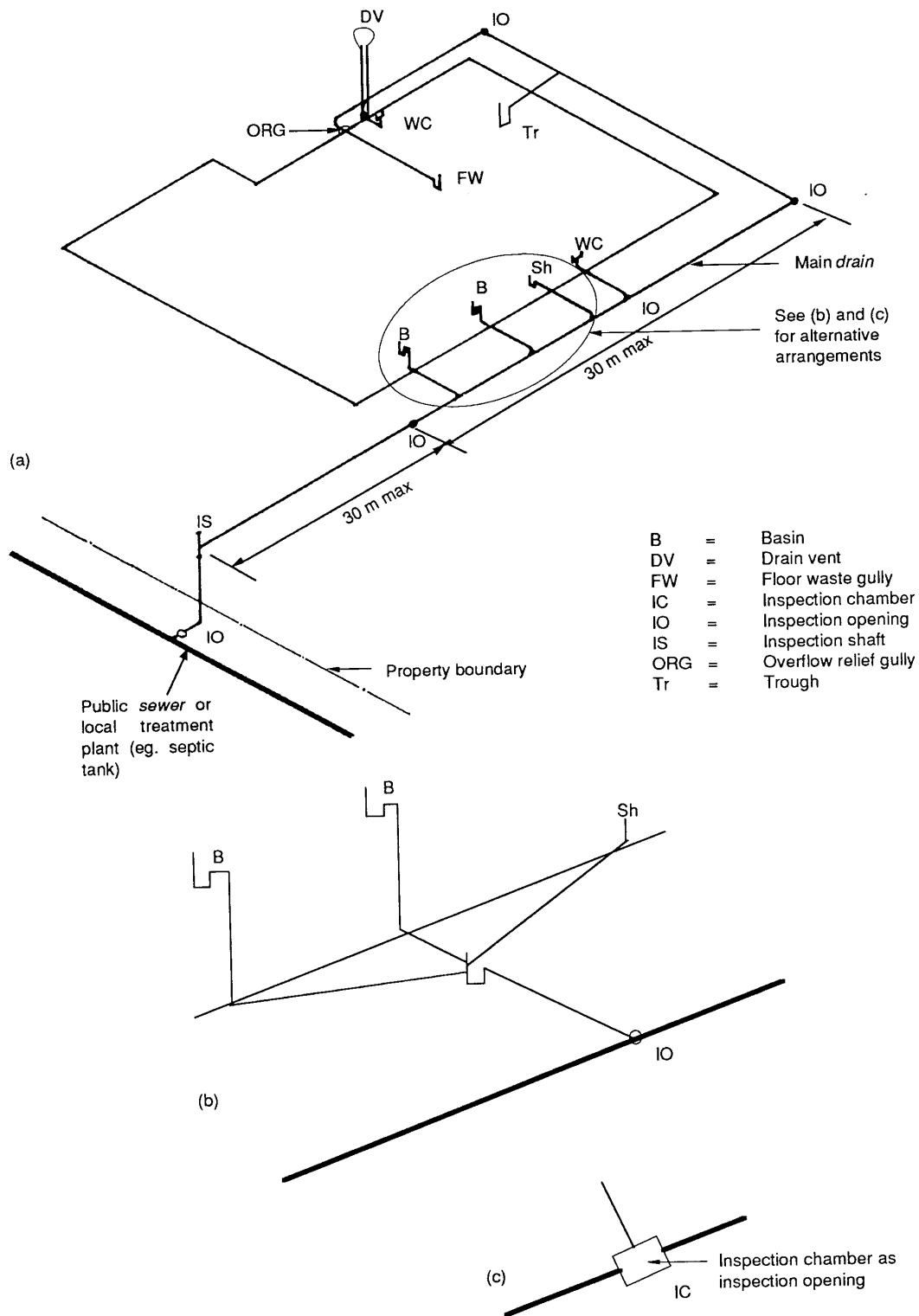

FIGURE DF6.11.2 LOCATION OF INSPECTION OPENINGS

- 
- (ii) not be Y *junctions* in the horizontal plane; and
  - (iii) where unequal *junctions* are used have the soffit of the branch in level with or higher than the soffit of the larger size.
- (b) Square *junctions* in *drains* must only be used:
- (i) at the connection of an inspection shaft to a graded *drain*;
  - (ii) as the inlet riser of a gully or a floor waste gully;
  - (iii) as an inspection opening; or
  - (iv) at the top of a drop *junction* in place of a bend and inspection opening.
-

## ROOF DRAINAGE

### DF7.1 Design of roof gutters

(a) Roof gutters where provided must be sized on the basis of the rainfall intensity using Figure DF7.1. The figure gives values of the net area of cross-section of the gutter for different roof catchment areas and different rainfall intensities. Eaves gutters must be sized for a rainfall intensity corresponding

to a 20-year return period where as internal box and valley gutters must be sized for a 100 year return period intensity. For temporary structures it is enough if all gutters are sized for a 5 year return intensity. The Meteorological Department may be contacted to supply 100-year, 20 –year and 5-year return period intensities in mm/hr of rainfall for representative areas in the country.

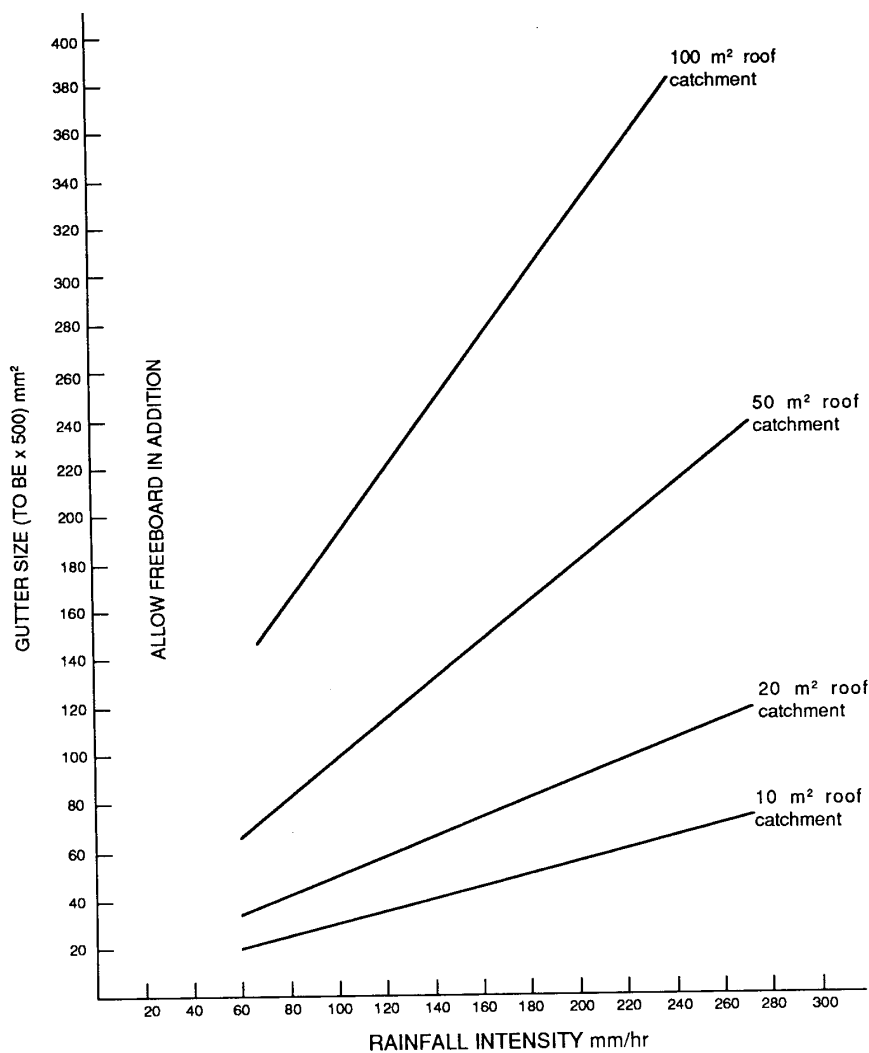

FIGURE DF7.1 GUTTER SIZES AND RAINFALL INTENSITY

**Notes:**

- (1) The roof catchment area is the area of the roof drained by one downpipe. It is taken as the area of the roof from ridge to gutter between two adjacent downpipes.
- (2) Values can be interpolated for catchment areas falling between the given figures.
- (3) The gutter sizes do not include any allowance for freeboard. A freeboard of 25 mm for eaves gutters and 35 mm for internal box gutters must be added to the cross-sections derived from the table.

---

(b) Gutters must have a minimum slope of:

- (i) 1 in 500 for eaves gutters; and
- (ii) 1 in 200 for internal box gutters.

These slopes must be increased where there is any material risk of clogging of the gutters and downpipes with leaves and other such matter.

**Note:**

With high fronted eaves with fascia boards there could be overflow from the back of the gutter into the building if the downpipes or gutters are blocked. One method of preventing such overflow is by providing drainage slots along the front of the gutter at a level lower than the back edge. Another method would be to provide sumps and weirs at the ends of the gutter or where the downpipes take off. The risk of overflow into the building from any internal box gutter can be reduced by providing sumps and weirs at the ends of the gutter.

**DF7.2 Design of downpipes**

The minimum area of cross-section of a downpipe must be the greater of:

- (a) half the area of cross-section of the gutter it serves; or
- (b) the area calculated for each 10m<sup>2</sup> of the roof area drained by it at the rate of:
  - (i) 650 mm<sup>2</sup> for eaves gutters; and
  - (ii) 930 mm<sup>2</sup> for internal box gutters.

**DF7.3 Incompatible metals for gutters**

Direct contact between the following metals must be avoided in order to prevent corrosion:

Zinc or aluminum	}	{copper or copper alloys
and	}	{ and
alloys of either	}	{some grades of
		{stainless steel.

---

## LATRINES FOR AREAS WHERE THERE IS NO PIPES WATER SUPPLY

### 1. Scope

This specification sets out the requirements in relation to the location and types of latrines in area where there is no piped water supply.

### 2. Precautions

Care must be exercised to ensure that:

- (a) disease transmitting flies and other insects do not have access to the excreta.
- (b) there is no nuisance to the public or the neighbours.
- (c) the sub-soil water is not polluted if it is likely to be used for domestic purposes.
- (d) the biological oxygen demand (BOD) of any resulting effluent is limited to the requirements of the Department of Health so that streams rivers and oceans are not polluted.

### 3. Location

The latrines must be screened from public view and be located not less than:-

- (a) 30 metres from any well or other similar potable source of water.
- (b) 6 metres from the front or street boundary of the allotment.
- (c) 3 metres from any boundary other than the front or street boundary.
- (d) 3 metres from any dwelling within or outside the allotment.

### 4. Types of latrines

All new pit latrines shall conform with Figures 4.1, 4.2 and 4.3.

- 4.1** Latrine pits located within the Marine and River Protection Zones shall be sealed with cement mortar, polyethylene or similar liner to avoid soakage of effluent to marine and river waters.



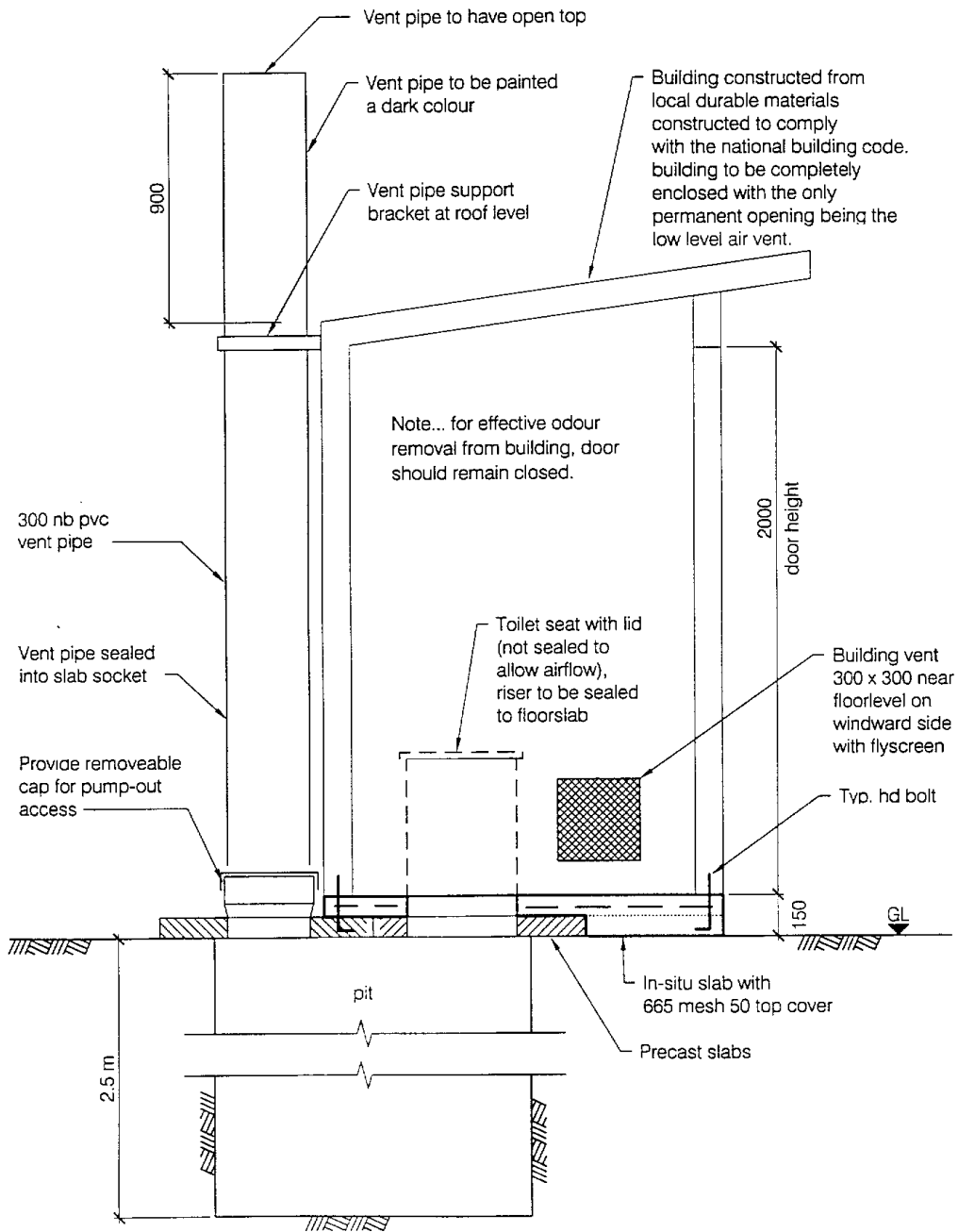

FIG 4.1 STANDARD VENTILATED IMPROVED (VIP) PIT LATRINE GENERAL ARRANGEMENT

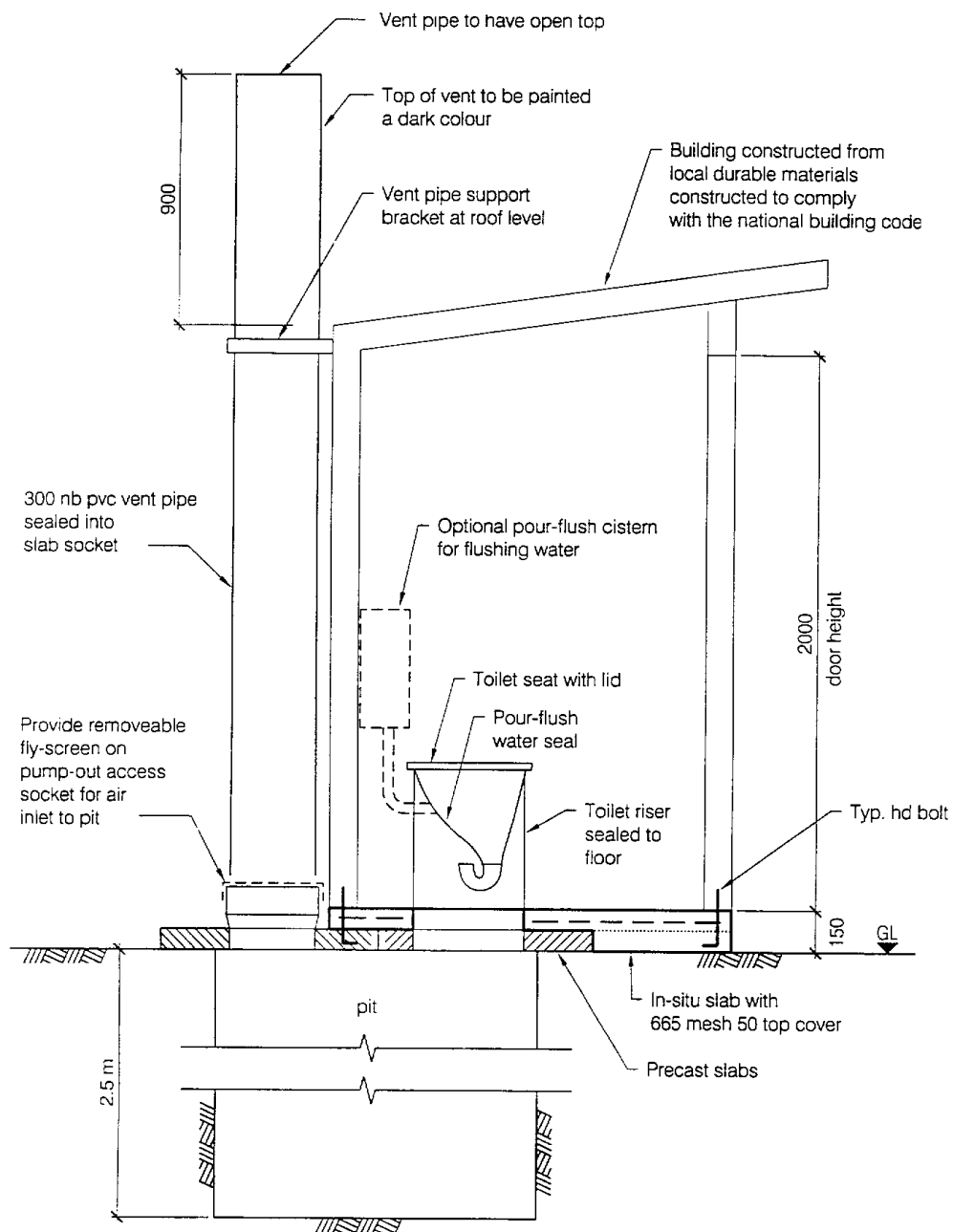

FIG 4.2 VENTILATED IMPROVED (VIP) PIT  
LATRINE WITH WATERSEAL GENERAL ARRANGEMENT

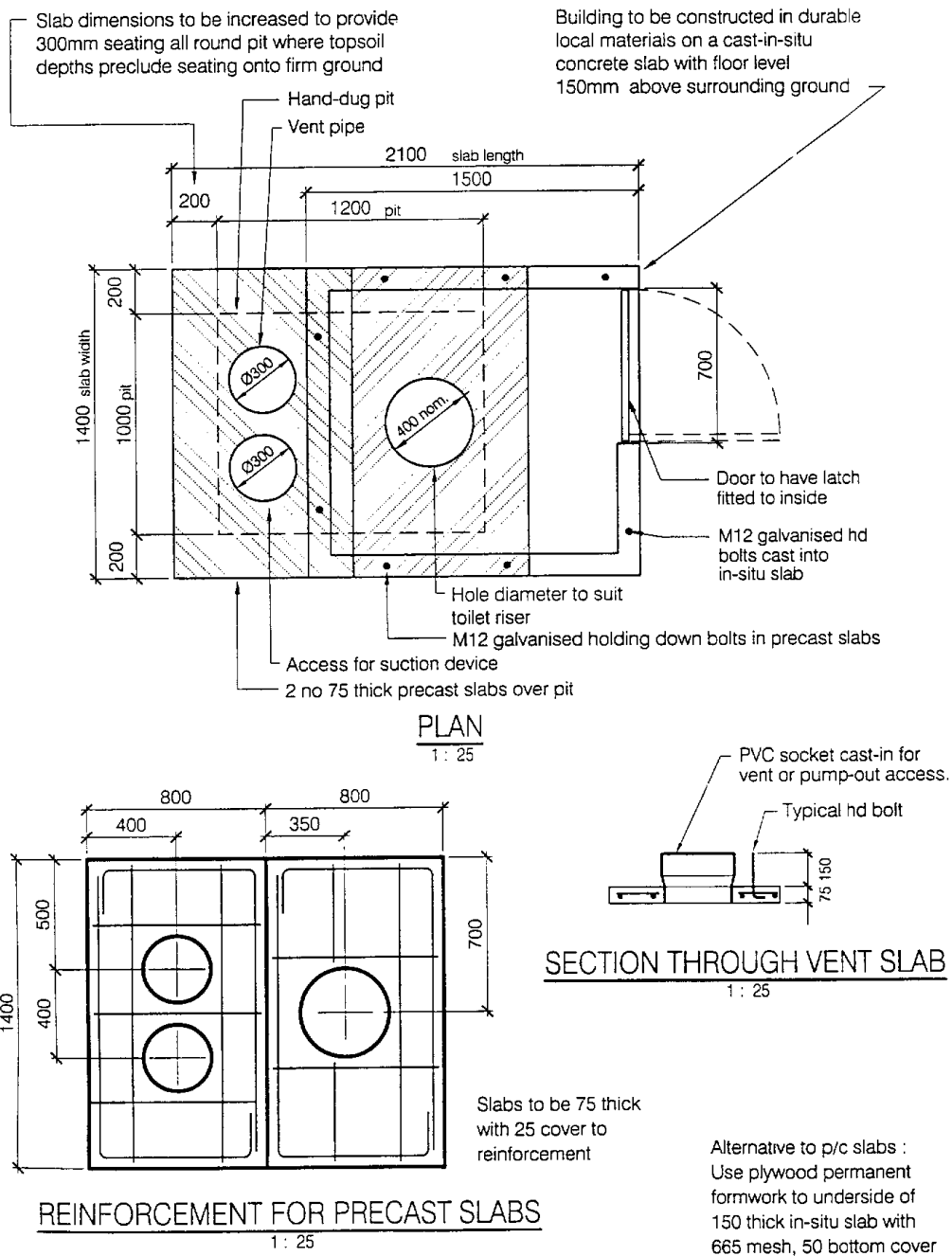

FIG 4.3 BASIC OR ENHANCED PIT LATRINE PLAN AND SLAB DETAILS

---

## SEPTIC TANKS FOR DOMESTIC USE

### 1. Function of a septic tank

The basic function of a household septic tank is to receive normal liquid household wastes and to condition them for such a time, and in such a manner, that the clarified effluent may be percolated efficiently into the subsoil, where it is absorbed and evaporated. In order to perform this basic function, all septic tanks must fulfill the following requirements:

#### (a) Remove solids

A septic tank must have a primary or liquefying chamber of such shape and size that the rate flow of all sewage is so reduced that at least the larger solids sink to the bottom and are retained and the clarified effluent is discharged. The inlet and outlet pipe of this primary chamber must be so shaped and located that the scum which forms on the surface of the sewage is not disturbed. The capacity of the tank is usually kept equal to the inflow during 24 hours to allow a day's retention.

#### (b) Promote bacterial action

To ensure that the solids and liquids in the tank will decompose it is necessary that the tank be designed so that either –

- (i) a variety of bacteria – anaerobic bacteria – which thrive in the absence of free oxygen are present; or
- (ii) a variety of bacteria – aerobic bacteria which thrive with access to air is also present.

A tank that is designed to achieve the purpose defined in (i) is a single-treatment septic tank, and a tank that is designed to achieve the purpose defined in (ii) is a double-treatment septic tank. A double-treatment tank is generally more expensive. Therefore details of only single-treatment tanks with or without aerobic filters will be included in this Specification.

#### (c) Store sludge

A fine slit-like sludge accumulates at the base of the primary tank. It follows that the primary tank must be of sufficient size to store sludge for a considerable period; otherwise, if the tank is not cleaned out at frequent intervals, the sludge will eventually

be scoured from the tank and clog the outlet drain, the absorption trench or soil and an aerobic filter where provided.

### 2. Location

Septic tanks and other connected works such as absorption trenches and soak pits must be located at a sufficient distance to prevent contamination of potable water sources and nuisance. Figure 2 shows typical layouts with the minimum separation distances marked on them. It will be seen that a minimum distance of 30 m is *required* between soak pits and potable water sources whereas this distance is only 15 m in the case of absorption trenches.

Another important consideration in the siting of a septic tank is that an adequately absorbent area must be available for discharging the effluent through absorption trenches or soak pits.

### 3. Construction

**3.1** Septic tanks may be of reinforced concrete or of reinforced block masonry walls over a reinforced concrete base. Tanks of precast concrete construction may be made from rectangular slabs which are assembled on the site, or be of cylindrical construction, either as a single cylinders open at the top, or a stack of short, open-ended cylinders.

**3.1.5** Fibreglass septic tanks shall be permitted where they cater for households of up to 10 persons, provided the tank capacities shall not be less than:

- 2 500 litres, where only toilet waste is treated.
- 4,500 litres, where all sewage, including bathing and kitchen waste water is treated.

**3.2** Whatever form of construction or materials are used for the sides and bottoms of septic tanks the resulting work must be impervious to water. For tanks of rectangular section, it is important that all internal angles be well-rounded, so as to minimize shrinkage cracking. Leakage at the corners of tanks of precast concrete construction made from rectangular slabs, or at the joints of precast tanks made from a number of open-ended cylinders, must be detected and corrected in advance.

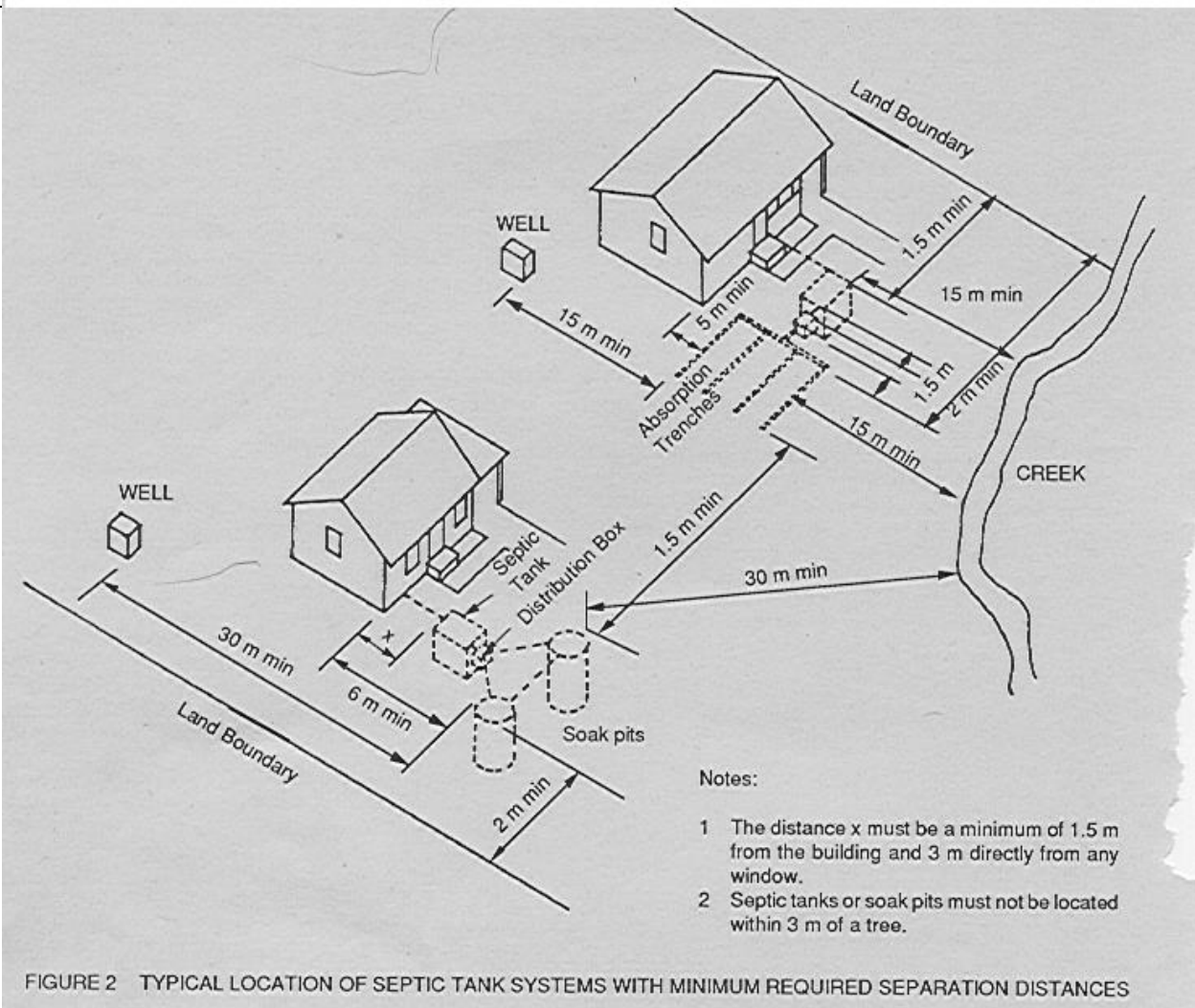

FIGURE 2 TYPICAL LOCATION OF SEPTIC TANK SYSTEMS WITH MINIMUM REQUIRED SEPARATION DISTANCES

**3.3** Every septic tank of block masonry or concrete construction must be covered with reinforced concrete slabs and removable manhole covers fitted over every compartment. The manholes are used when it is necessary to pump out or otherwise clean the tanks. Inspection openings are also required over the inlet and outlet square junctions. The aerobic filter where provided must be filled with hard, impervious and durable stone, coral or gravel. These must be graded from 60 mm to 75 mm.

**3.4 Design details**

Septic tanks shall be designed in accordance with Figure 3.4 and Table 3.4A and 3.4B.

**3.5** Figure 3.5 shows an arrangement for aerobic filters. The filter chamber can also serve as a distribution box for the absorption trenches.

**4 Grease traps**

**4.1** The satisfactory disposal of the discharge from kitchen waste fixture is frequently difficult because it is charge with grease which cannot be satisfactorily dealt with in a septic tank. This difficulty may be overcome by a grease trap located near the kitchen through which all discharge from the kitchen must pass before entering the drain to the septic tank. For satisfactory working of the trap it is necessary that both laundry and roof waters, and liquid and powder detergents, be excluded from it. A grease trap constructed as shown in Fig 4.1 has been found effective in arresting grease.

**TABLE 3.4A**  
**SEPTIC TANK DIMENSIONS AND VOLUMES OF AEROBIC FILTER**

No. of Persons	ONLY SOIL WASTE						
	A	B	C	D	W	V(m3)	F(m3)
8	1000	400	1000	850	800	0.95	0.02
10	1000	600	1000	850	800	1.22	0.02
12	1000	600	1000	850	800	1.22	0.02
15	1000	600	1200	1050	800	1.34	0.03
25	1200	800	1200	1050	1000	2.10	0.05
50	1600	800	1400	1250	1000	3.00	0.06
100	2400	1200	1400	1250	1200	5.40	0.11
150	2600	1400	1600	1450	1400	8.12	0.16
200	3000	1600	1600	1450	1600	10.67	0.21
300	3400	1800	1800	1650	1800	15.44	0.31
400	4000	2200	1800	1650	2000	20.46	0.41
500	4200	2200	1800	1650	2400	25.34	0.51
600	4400	2400	2000	1850	2400	30.19	0.61

No. of Persons	ALL DOMESTIC WASTE						
	A	B	C	D	W	V(m3)	V(m3)
8	1400	800	1000	850	1000	1.87	0.04
10	1400	800	1200	1050	1000	2.31	0.05
12	1800	800	1200	1050	1000	2.73	0.06
15	1800	800	1200	1050	1200	3.28	0.07
25	2000	1200	1400	1250	1400	5.60	0.11
50	3200	1600	1600	1450	1600	11.14	0.22
100	4000	2000	1800	1650	2200	21.78	0.44
150	5000	2400	2000	1850	2400	32.86	0.66
200	5600	2400	2000	1850	3000	44.40	0.89
300	6600	3400	2000	1850	3600	66.60	1.33
400	8000	4000	2000	1850	4000	88.80	1.78
500	8200	4200	2000	1850	4800	110.11	2.20
600	9000	4800	4000	1850	5200	132.76	2.66

V = Volume of Septic Tank; F = Volume of Aerobic Filter; For details of A,B,C,D and W see Figures 3, 4A and B

**TABLE 3.4 B  
REINFORCEMENT FOR MASONRY SEPTIC TANKS**

Block wall thickness	Height of Tank (m)	Vertical	Horizontal bars
150	1.0	D10 @ 600	D12 @ 600
	1.2	D12 @ 600	D12 @ 600
	1.4	D12 @ 400	D12 @ 600
200	1.6	D12 @ 400	D12 @ 600
	1.8	D16 @ 600	D12 @ 600
	2.0	D12 @ 400 fill all cells	D16 @ 600

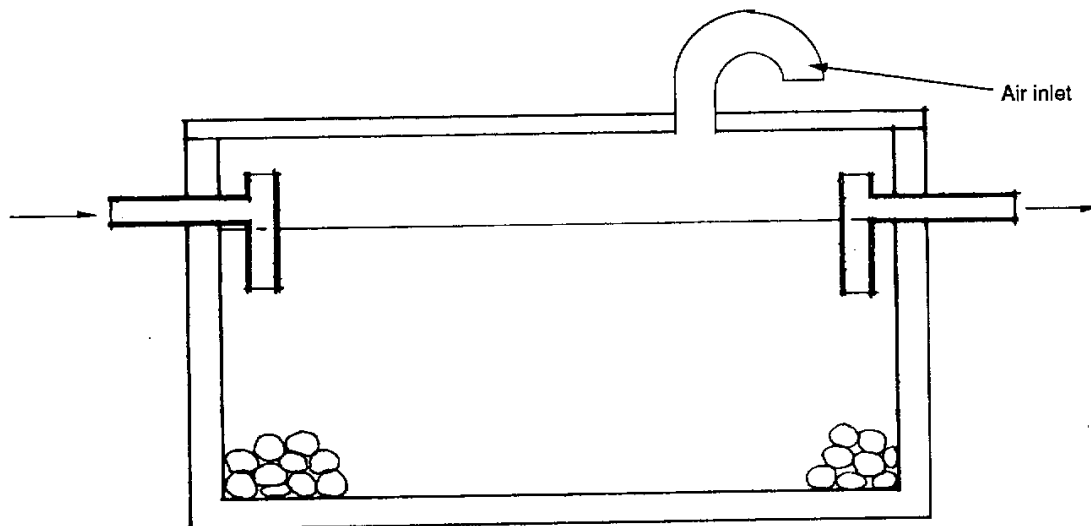

**FIGURE 3.5 AEROBIC FILTER**

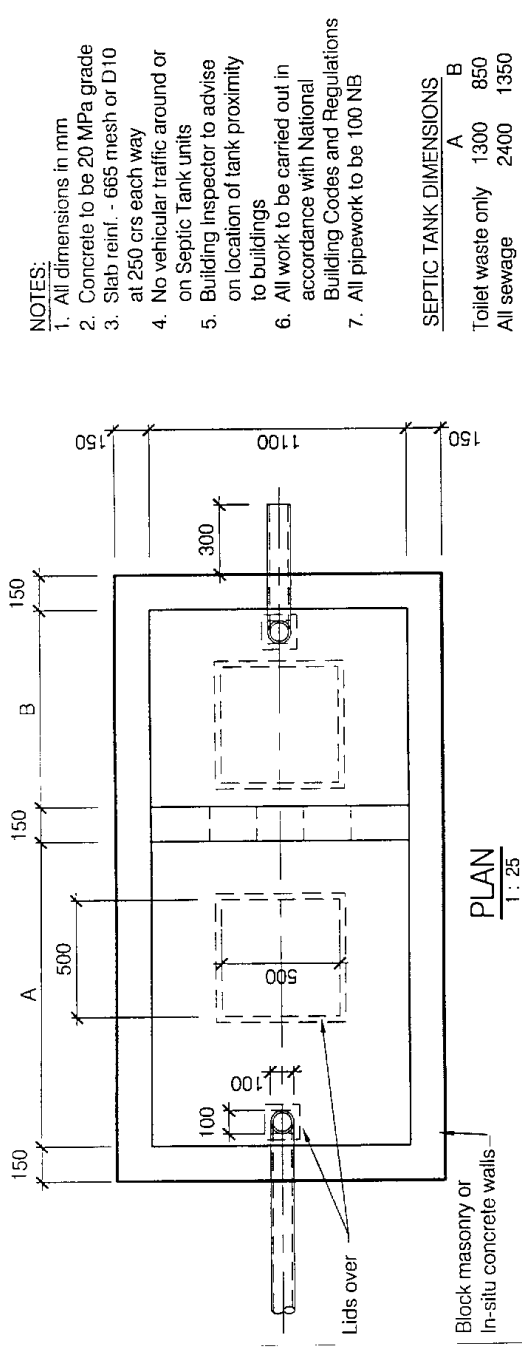

- NOTES:**
1. All dimensions in mm
  2. Concrete to be 20 MPa grade
  3. Slab reinf. - 665 mesh or D10 at 250 crs each way
  4. No vehicular traffic around or on Septic Tank units
  5. Building Inspector to advise on location of tank proximity to buildings
  6. All work to be carried out in accordance with National Building Codes and Regulations
  7. All pipework to be 100 NB

**SEPTIC TANK DIMENSIONS**

	A	B
Toilet waste only	1300	850
All sewage	2400	1350

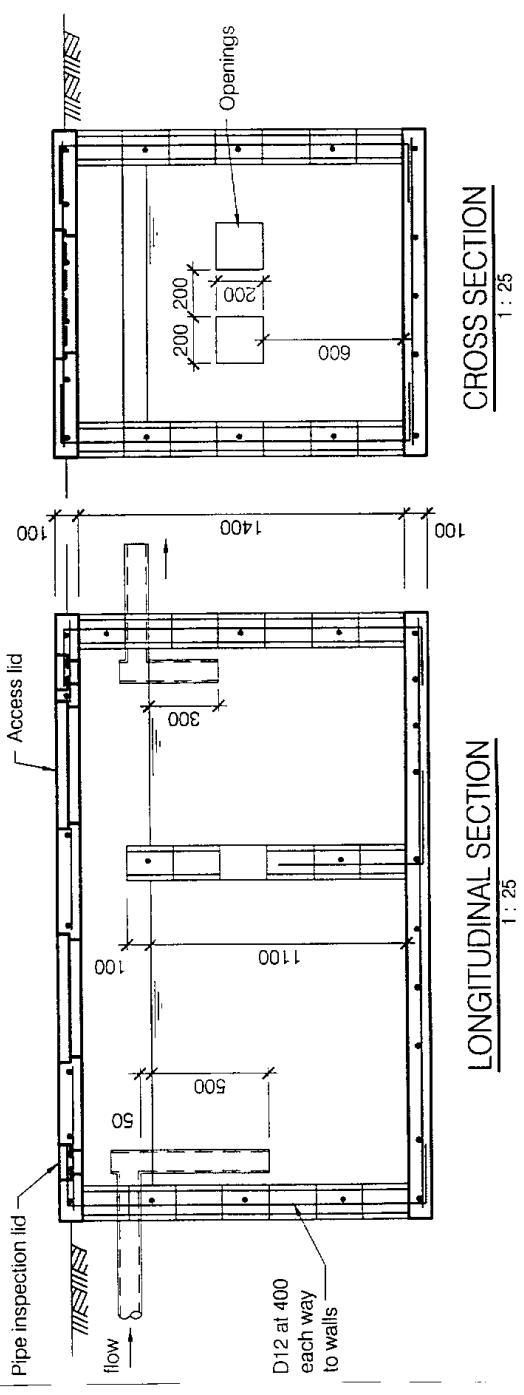
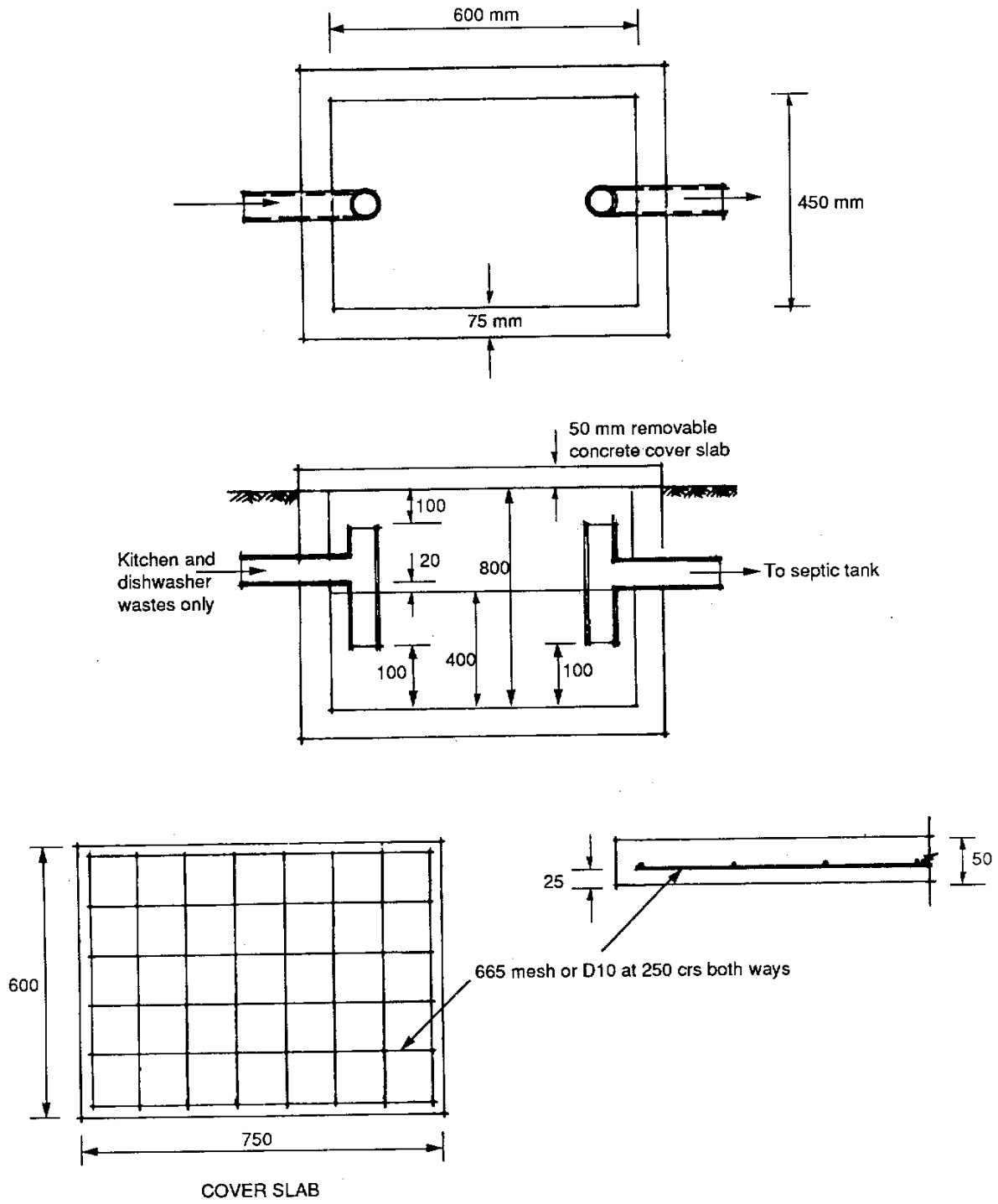

FIG 3.4 CONCRETE SEPTIC TANK FOR DOMESTIC USE





Notes:

- 1 All dimensions in mm.
- 2 Concrete to be 20 MPa grade
- 3 Reinforcement - 665 mesh or D10 at 250 crs both ways all around.

FIGURE 4.1 DETAILS OF A GREASE TRAP

---

Alternatively, a smaller precast concrete or other type of grease trap may be installed.

The capacity of the grease trap below the level of the invert of the outlet must be not less than the total capacity of the sinks and dishwashers served. The cover over the trap should be removable to facilitate the cleaning of the trap.

**4.2** If grease traps are not regularly cleared of the accumulated grease it would give rise to the blocking of drains, unsightly overflow through the sides of the cover slab of the trap and unpleasant odour.

## **5 Soakaway Design**

Effluent from domestic household septic tanks shall be piped and discharged into a properly designed soakaway (refer figure 5.1). The soakaway may consist of a separate soakaway pit which conforms to the following criteria:

- Minimum surface area of soakaway pit shall be 3m<sup>2</sup>.
- Base of soakaway pit shall be not less than 2.5 metres above high groundwater level.
- Soakaway pit shall be filled with large pieces of coral not less than 75mm in dimension.

- Coral fill shall be covered with rot resistant fabric, eg. Filter cloth, to stop soil washing into the soakaway.
- Fabric shall be covered with a minimum of 300mm of soil.

Alternately the soakaway may be integrated with the septic tank by constructing a soakaway of sufficient area, as above, under and around the base of the tank as follows:

- Excavate the septic tank pit 500mm deeper than usual and backfill with strong coral fill dimensions 75mm or greater to a depth of at least 500mm.
- Cover the coral fill with building plastic prior to placing the concrete base slab of the septic tank.
- Complete the septic tank construction and pipe the effluent so that is evenly dispersed through the soakaway around and underneath the tank.

### **5.1 DESLUDGING**

Desludging shall be carried out every two years, or when the sludge level fills more than half of the first chamber, whichever is the earliest.

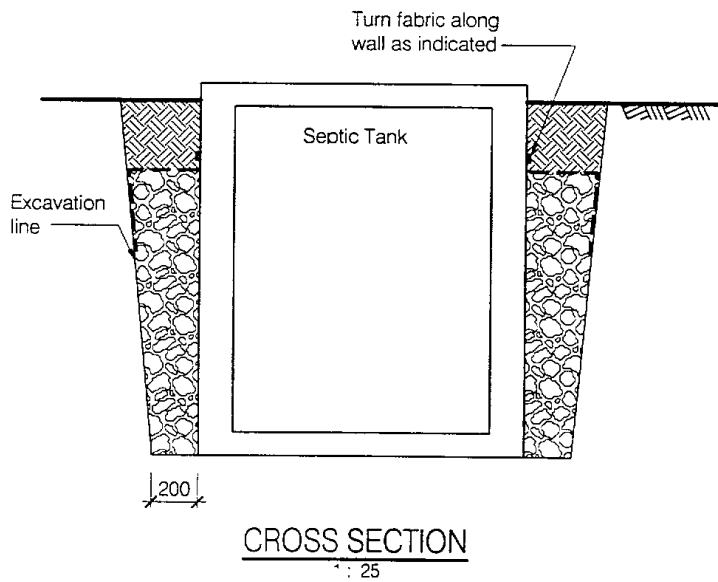
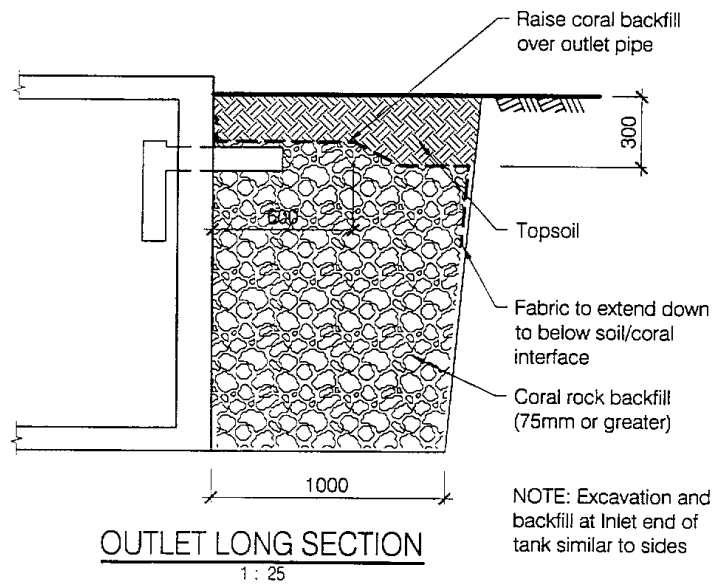

FIG 5.1 SOAKAWAY SYSTEM FOR DOMESTIC SEPTIC TANK

---

## **6 ENHANCED EFFLUENT SOAKAGE / FILTERING SYSTEMS**

### **6.1 APPLICATION**

Enhanced Septic tank Soakage / Filtering systems standards shall apply to septic tanks located within the *Marine and River Protection Zone*.

### **6.2 DESIGN**

One of the following enhanced systems shall be used:

- Soil Soakage Trenches
- Sand filters
- Mounds

Soil soakage trenches shall be used as the preferred method where there is sufficient area of land available, where the groundwater is more than

900mm below ground level and where there is medium or fine texture soil for a depth of at least 600mm below the surface of effluent application. The construction of Soil Soakage Trenches shall conform with the design requirements of Figure 6.3

In situations where a suitably located land area is not available, either a Sand Filter or Mound system shall be utilised. A sand filter conforming with the design requirements shown in Figure 6.2 shall be constructed in situations where there is sufficient soil cover. In situations where there is rock or tight soil close to the surface the Mound System as shown in Figure 6.4 shall be utilised.

In situations where a pump station is required integral with a septic tank details should be in accordance with figure 6.1 and figure 6.5.

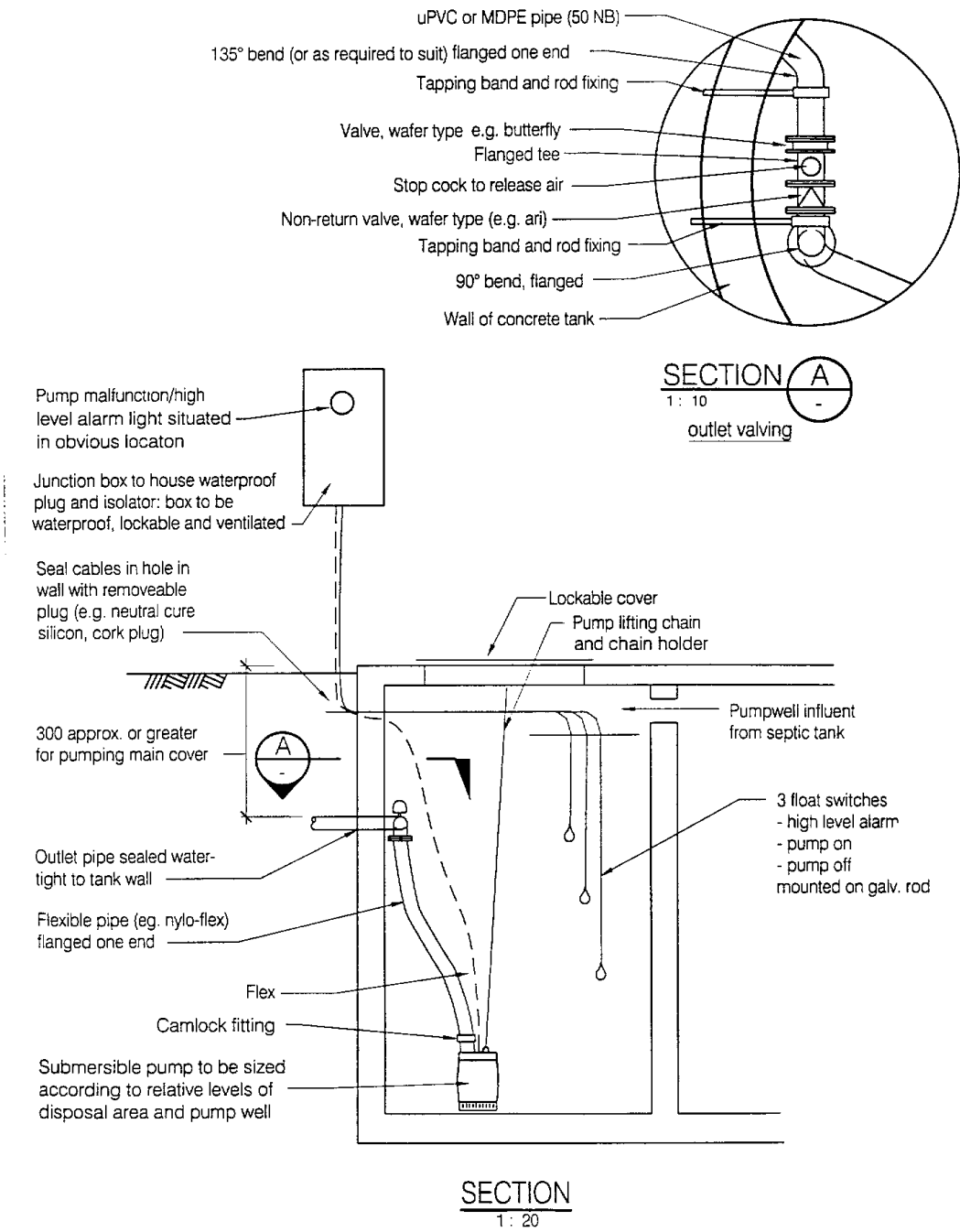
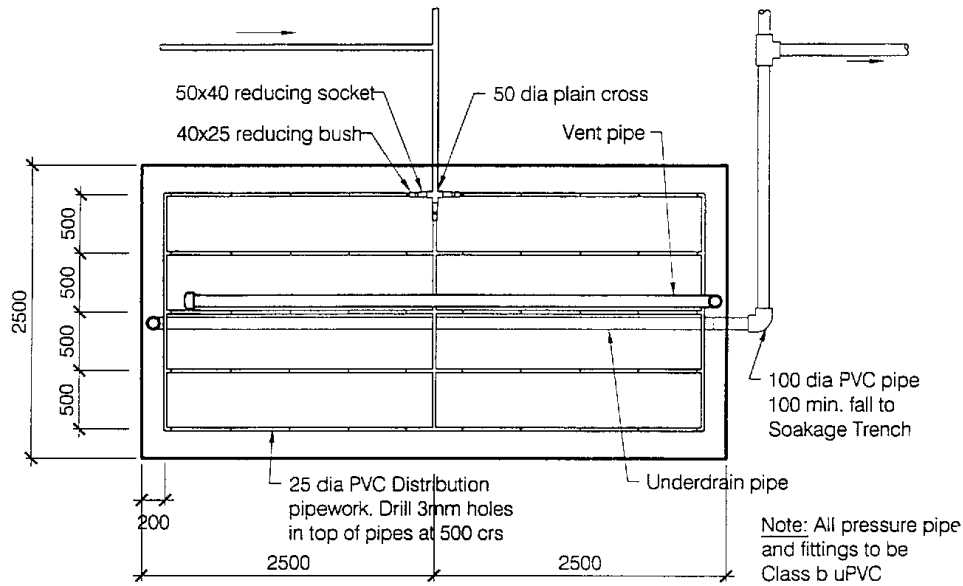
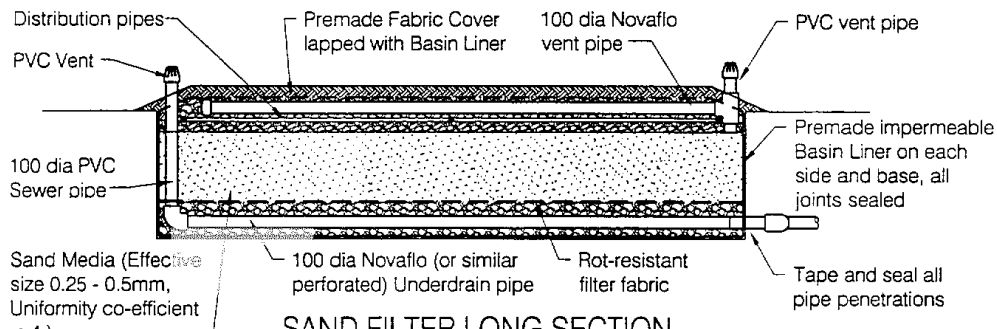

FIG 6.1 PUMP STATION INTEGRAL WITH SEPTIC TANK



**SAND FILTER PLAN**  
1: 50



**SAND FILTER LONG SECTION**  
1: 50

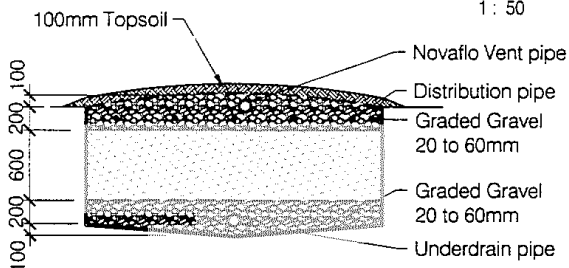

**SAND FILTER CROSS SECTION**  
1: 50

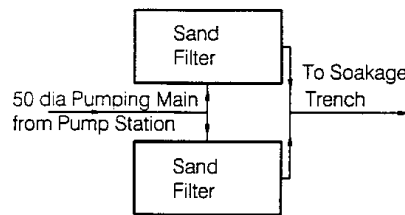

**LAYOUT PLAN**  
1: 200

FIG 6.2 INTERMITTENT BIOLOGICAL SAND FILTER

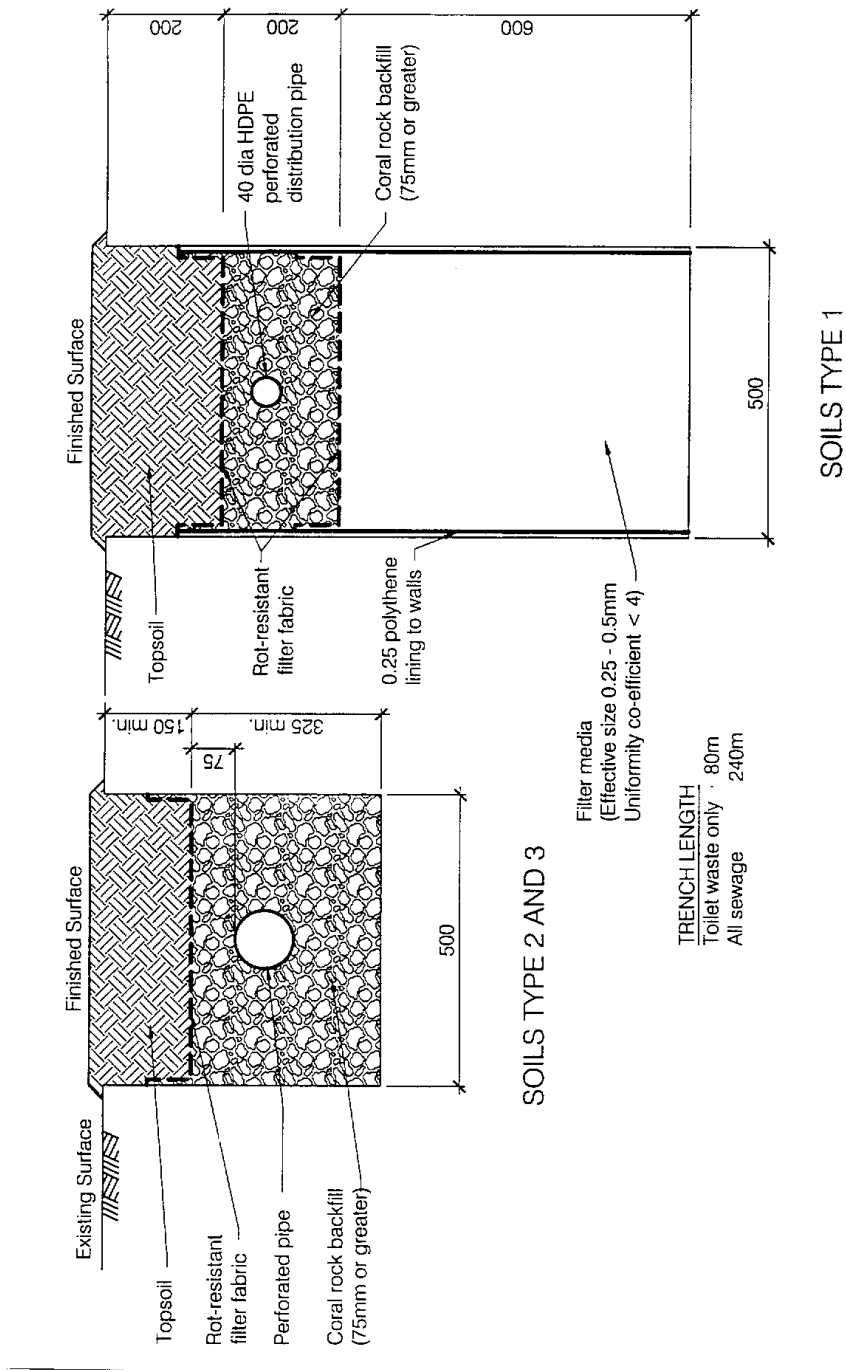
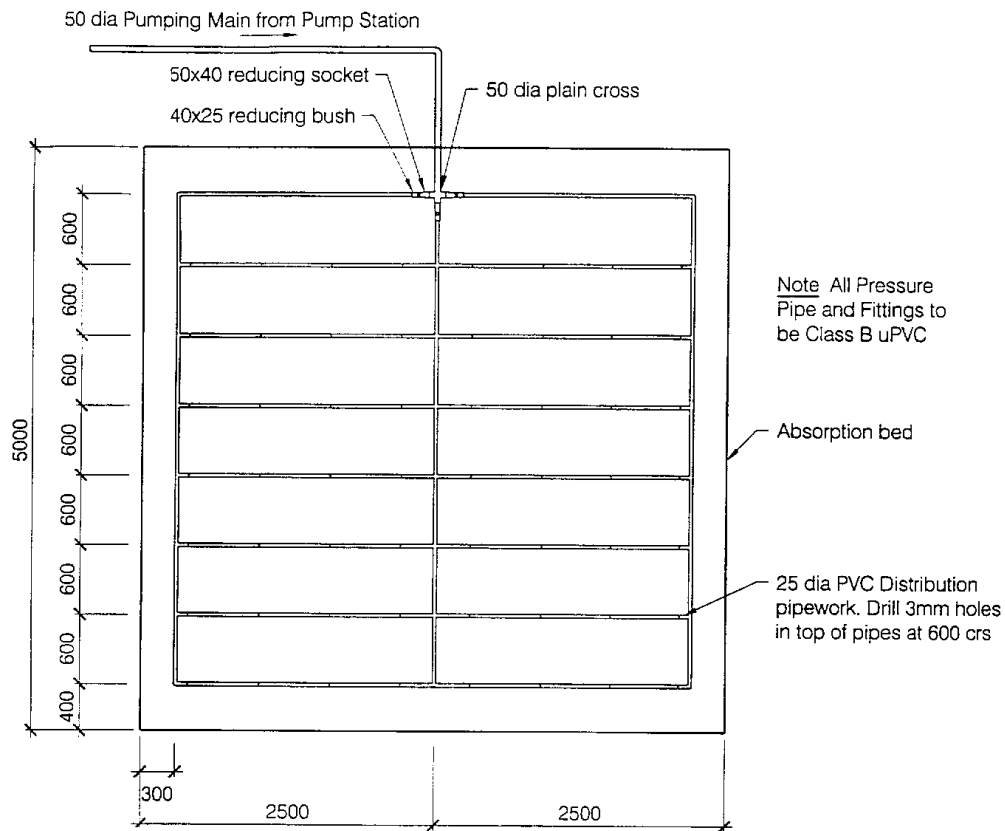
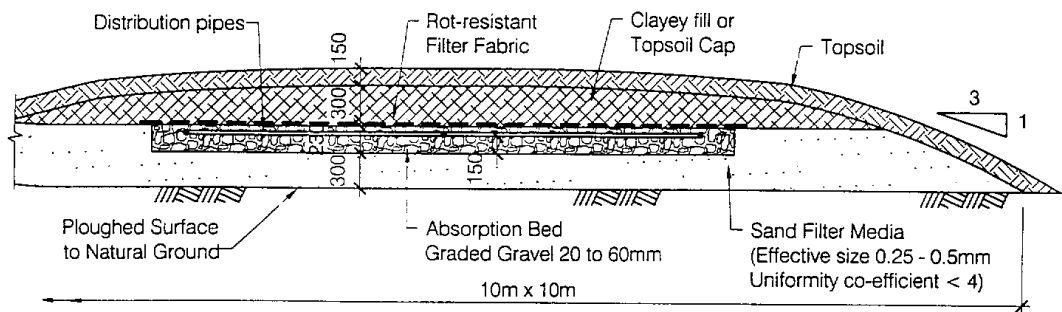

FIG 6.3 SOAK TRENCHES FOR DOMESTIC USE



**SAND FILTER PLAN**  
1: 50



**TYPICAL SECTION**  
1: 50

FIG 6.4 MOUND SYSTEM FOR DOMESTIC USE



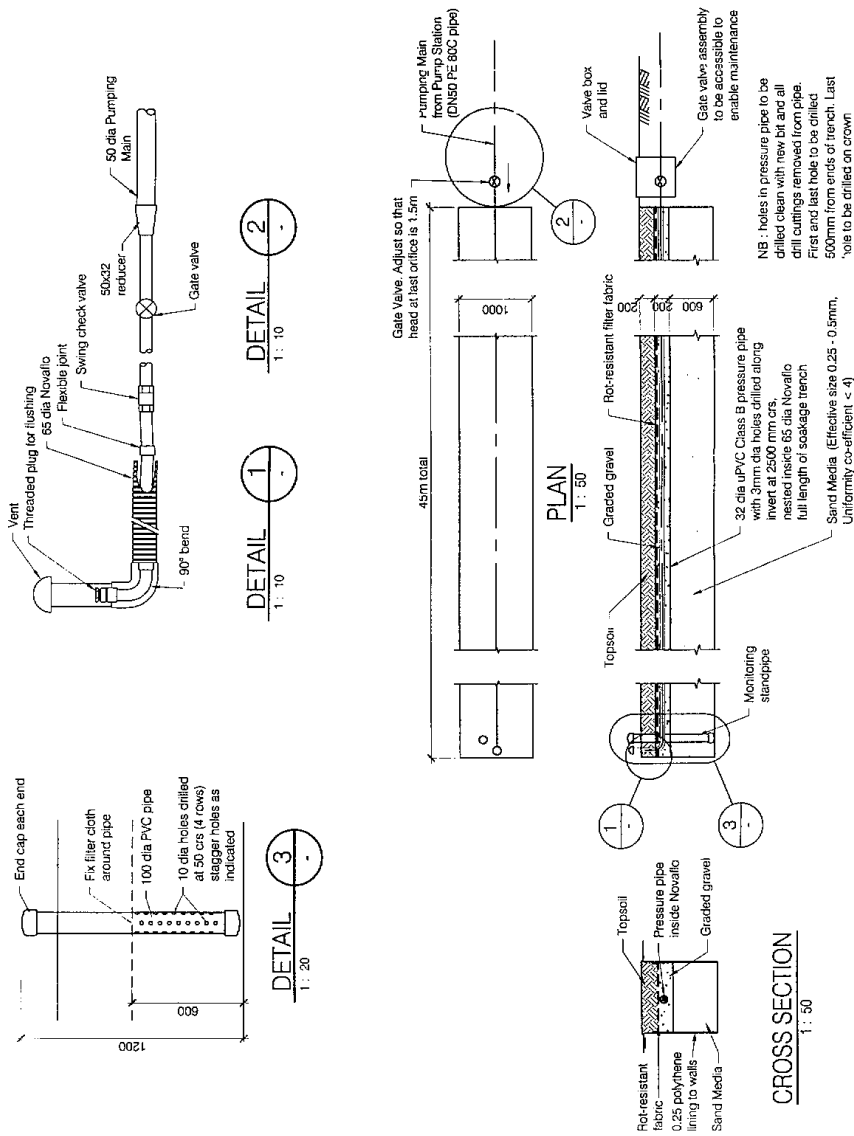

**DISCHARGE QUALITY CONTROL TRENCH LONGSECTION**  
1 : 50

FIG 6.5 DISCHARGE QUALITY CONTROL TRENCHES

## RAINWATER STORAGE

### 1. Introduction

Rainwater collection from the roof depends on a number of factors. Unless these are suitably matched the supply would not be satisfactory. The factors are:

- (a) the average annual rainfall and its variability through the year;
- (b) the roofing material and the available area of the roof;
- (c) the daily rate of consumption of water;
- (d) the storage volume and the material of the tank; and
- (e) the desired reliability of the supply.

### 2. Relationship of rainfall, variability, roof area and storage volume

The higher the average annual rainfall, the smaller the collection area of roof required for a given rate of consumption. In order to allow for variation in actual rainfall from the monthly averages, it is advisable to have the available roof area to be twice the theoretical area.

If the pattern of rainfall is fairly uniform through the year, the size of storage tank for a given rate of consumption would be relatively smaller. The tank size could be as small as to hold 50 days consumption where rainfall is quite uniform through the year. Where most (such as 75%) of the annual rainfall occurs in 3 or 4 months it will be necessary to size the tank to hold 100 to 120 days of consumption. This assumes that the available roof collection area is twice the theoretical area. Where the available roof area is less than about 1.4 times the theoretical area, the required storage volume tends to increase very steeply. The size of the tank determined from these considerations should normally give an average reliability of supply with a failure rate of about once every 5 years. If an average chance of failure of supply of once a year is acceptable, the calculated tank size can be reduced by about 30% in areas of high rainfall and by 40% in areas of lower rainfall.

### 3. Design

The theoretical relationship outlined in paragraph 2 can be expressed as:

$$A = 365 \times C/R \text{ where}$$

A is the roof area acting as the catchment in square metres,

C, the daily average consumption of water by the household in litres, and

R, the average annual rainfall in millimetres

However, for the reasons stated earlier the practical value of the roof catchment is:

$$A = 2 \times 365 \times C/R = 730 C/R$$

In order to assess the size of the storage tanks Vanuatu has been divided into 2 categories – areas with a more uniform spread of rainfall and those with rainfall concentrated over 3 or 4 months of the year. In the case of the areas with a more uniform rainfall, it is estimated that a storage capacity of 50 days consumption would be adequate to provide a reasonably reliable supply with the risk of failure of only once in 5 years. For a similar level of reliability in areas with an uneven spread rainfall, the estimated storage is equal to 80 days consumption.

Taking a family size of 5 members, each consuming no more than 30 litres per day of the stored water, the minimum roof area and storage capacity required in representative regions in Vanuatu have been calculated for the average rainfall in those regions. These are shown in Table 3. If the family size and/or daily consumption is different, the required roof area and tank size can easily be calculated from the Table.

<b>TABLE 3 MINIMUM ROOF AREA AND TANK CAPACITY FOR RAINWATER COLLECTION</b>		
Total tank capacity of 7.5 kilolitres (1700 gallons)		Total tank capacity of 12 kilolitres (2700 gallons)
Minimum roof catchment to drain into storage (m <sup>2</sup> )		
50	30	80
Efate		
Espiritu Santo	Vanual Lava	Tanna
Malekula		
Aneityum		
<p>Example: If the family size considered in say, Tanna is 7 and the daily consumption per head is 20 litres, the required roof catchment = <math>80 \times 20 \times 7 / (30 \times 5) = 75 \text{ m}^2</math>                      Tank size = <math>12 \times 20 \times 7 / (30 \times 5) = 11.2</math> kilolitres (2500 gallons)</p> <p>Note: If a risk of failure of supply once a year is acceptable, the tank size can be reduced by 30%.</p>		

---

#### **4. Effect of roofing material and the environment**

Rainwater in general is very pure and hence many metals dissolve in it much faster than in land based water. For instance if any lead is used in the roof for flashing or in the form of lead-based paint, the rainwater would leach the lead into the storage tank. If this happened, the water would not be potable. The nature of materials used in the roof must be ascertained and their safety confirmed before a decision is taken to use the run-off from the roof. In general galvanised iron sheets, zinc-aluminium coated sheets and a number of other products are safe.

As far as possible leaves and twigs must not be allowed to fall on the roof. The leached extracts from some leaves would make the water unfit for consumption. In addition the organic matter from leaves and twigs would encourage the growth of micro-organisms in the tank, thereby polluting the water. Accumulation of any dust on the roof, such as from industrial activity nearby would also make the water unfit.

#### **5. Tank material**

Tanks are generally made of galvanised or zinc-aluminium coated steel plates and sometimes of fibre glass. Whereas suitable fibreglass would be inert and therefore not affected by the rainwater, galvanised steel could. The greater the purity of the stored water, the greater the risk of the galvanising getting leached out very fast. If the roofing sheets are of galvanised steel, the stored water would already contain some of the zinc from the roofing material and hence the tank would last longer. This is not the case where the roofing is of zinc-aluminum coated or painted steel or of some other man-made material.

In order to prevent the corrosive effects of pure water on the tank coating, suitably formulated metaphosphates are commercially available. These produce a protective film inside the tank and thus

extend the life of metal coated tanks. Such methods must be used from the very first filling of the tank. There are also plastic protective coatings compatible with potability which are applied to metal tanks. The inside of the tank must not be painted with any ordinary paint.

In no case must lead be used in any form such as in sheets for flashing or as paint etc on roofs from which water is collected.

#### **6. Erection of rainwater tanks**

It is best to erect the tank in a shady location but away from falling leaves which could clog the strainer, and in the case of translucent material like fibreglass, have a dark colour to exclude light. Organic growth could develop on the sides of tanks in the presence of light and warmth. When the tank is part empty the organic growth would decay and give off gases, discolour the water, and produce corrosive acids. The absorption of the gases and acids could also give the water an unpleasant flavour.

The overflow pipes fitted to tanks for the disposal of excess inflow of rainwater must be adequate to prevent uncontrolled overflow. Such pipe must not terminate very close to storm water drains and soak pits as otherwise unpleasant gases might enter the tank. The pipe end and all opening to the tanks must be fitted with strong, durable mesh to prevent birds, mosquitoes and other insects gaining entry into the tank.

No copper pipe should be used with any metal water tank. The inlet pipe must discharge the water through a durable strainer fitted well above the high water level. The inlet must not be close to the tank wall. Where tanks are interconnected each tank must receive at least some of the water directly from the roof. No tank must get its supply entirely from other tanks. It is convenient to have individual domestic tanks of no greater capacity than 4 or 5 kilolitres (1000 gallons)

---

NATIONAL  
BUILDING  
CODE  
2000

DWELLINGS AND OUTBUILDINGS (CLASS 1 AND 10)

SECTION **DG**

---

**ANCILLARY PROVISIONS**

---

**Performance Requirements  
Deemed-to-Satisfy Provisions**

**DG1     Minor Structures and Components**

**DG2     Fireplaces, Chimneys and Flues**

---

---

# CONTENTS

## PERFORMANCE REQUIREMENTS

## DEEMED-TO-SATISFY PROVISIONS

Part

**DG1 Minor Structures and Components**

DG1.1 Swimming pools

DG1.2 Poultry and other Domestic Animal Houses

DG1.3 Fences

Part

**DG2 Fireplaces, Chimneys and Flues**

DG2.1 General requirements

DG2.2 Open fireplaces deemed-to-satisfy

---

## PERFORMANCE REQUIREMENTS

### OBJECTIVES AND REQUIRED PERFORMANCE

This section contains more specific requirements for particular parts of Class 1 and 10 buildings.

Parts of buildings and structures must be so designed and constructed that the following requirements **in addition** to those listed for Sections B, DC, and DF where relevant, are fulfilled.

#### DGP1 Minor Structures and Components

##### DGP1.1 Swimming pools –

- (a) Suitable means for the disposal of waste and drainage must be provided to a swimming pool.
- (b) Access by unsupervised young children to *swimming pools* must be restricted.

##### DGP1.2 Aesthetics

Any minor structure such as fencing awnings and the like must be suited to the general surroundings as well as the occupancy of the building and the neighbourhood.

##### DGP1.3 Animal houses

Accommodation for animals and poultry must not lead to unsanitary conditions for the occupier or neighbours and the public. The accommodation must be such that the animals or poultry are not subjected to serious discomfort or overcrowding.

#### DGP2 Fireplaces, Chimneys and Flues

Fireplaces, chimneys and flues must be adequately constructed or separated to prevent –

- (a) ignition of nearby parts of the building; or
- (b) escape or discharge of smoke to the inside of the building or to adjacent *windows*, ventilation inlets, or the like.

---

## DEEMED-TO-SATISFY PROVISIONS

### MINOR STRUCTURES AND COMPONENTS

#### DG1.1 Swimming pools

- (a) **Drainage:** A *Swimming pool* must have suitable means of drainage.
- (b) **Safety fencing:** A *swimming pool* with a depth of water more than 300 mm must have suitable barriers of safety fencing in accordance with AS 2818 and AS 1926 to restrict access by young children-
- (i) to the allotment or the immediate pool surrounds if there is only one Class 1 building on the allotment; or
  - (ii) to the immediate pool surrounds if the *swimming pools* is associated with a number of Class 1 buildings on the same allotment.

#### DG1.2 Poultry and other Domestic Animal Houses

A building used for keeping domestic birds or animals must be not less than:

- (a) 12 m from any Class 1 building;

- (b) 10 m from any boundary; and

- (c) 20 m from the boundary adjoining an allotment containing or intended to contain any building other than a Class 1 building.

The floor of the building must be constructed of suitable material. Suitable arrangements must be made for the collection and disposal of animal wastes, so that they do not create a nuisance or encourage the breeding of flies and other pests. The size and general arrangements in the building must be conducive to the welfare of the poultry or animals.

#### DG1.3 Fences

Any fencing or free standing wall must be suited to the occupancy of the building within. It must not detract from the general aesthetic appearance of the surroundings. If any barbed wire or other such is used it must be at a height of not less than 2 m above the finished level of any existing or intended adjacent footpath.

---

## FIREPLACES, CHIMNEYS AND FLUES

### DG2.1 General requirements

A chimney or flue must be constructed –

- (a) to withstand the temperatures likely to be generated by the appliance to which it is connected;
- (b) so that the temperature of the exposed faces will not exceed a level that would cause damage to nearby parts of the building;
- (c) so that hot products of combustion will not-
  - (i) escape through the walls of the chimney or flue; or
  - (ii) discharge in a position that will cause fire to spread to nearby *combustible* materials or allow smoke to penetrate through nearby-*windows*, ventilation inlets, or the like;
- (d) in such a manner as to prevent rainwater penetrating to any part of the interior of the building;
- (e) such that its termination is not less than:
  - (i) 600 mm above any point of penetration of or contact with the roof; and
  - (ii) 900 above any opening or openable part in any building, which is within 3 m horizontal distance of the chimney or flue; and
- (f) so that it is accessible for cleaning.

### DG2.2 Open fireplaces deemed-to-satisfy

An open fireplace, or solid-fuel burning appliance in which the fuel-burning compartment is not enclosed, satisfies DG2.1 if it has-

- (a) a hearth constructed of stone, concrete, masonry or similar *non-combustible* material so that –
  - (i) it extends not less than 300 mm beyond the front of the fireplace opening and not

less than 150 mm beyond each side of that opening;

- (ii) it extends beyond the limits of the fireplace or appliance not less than 300 mm if the fireplace or appliance is free-standing from any wall of the room;
  - (iii) its upper surface does not slope away from the grate or appliance; and
  - (iv) *combustible* material situated below the hearth (but not below that part *required* to extend beyond the fireplace opening or the limits of the fireplace) is not less than 155mm from the upper surface of the hearth;
- (b) walls forming the sides and back of the fireplace up to not less than 300 mm above the underside of the arch or lintel which –
    - (i) are constructed in 2 separate leaves of solid masonry not less than 180 mm thick, excluding any cavity; and
    - (ii) do not consist of concrete block masonry in the construction of the inner leaf;
  - (c) walls of the chimney above the level referred to in (b) –
    - (i) constructed of masonry units with a net volume, excluding cored and similar holes, not less than 75% of their gross volume, measured on the overall rectangular shape of the units, and with an actual thickness of not less than 90 mm; and
    - (ii) lined internally to a thickness of not less than 12 mm with rendering consisting of 1 part cement, 3 parts lime, and 10 parts sand by volume, or other suitable material; and
  - (d) suitable damp-proof courses or flashing to maintain weather proofing.



**PUBLIC BUILDINGS AND GROUP DWELLINGS (CLASS 2 TO 9)**

SECTION **NC**

---

**FIRE RESISTANCE**

---

**Performance Requirements  
Deemed-to-Satisfy Provisions**

- NC1**    **Fire Resistance and Stability**
  - NC2**    **Compartmentation and Separation**
  - NC3**    **Protection of Openings**
-

---

## CONTENTS

### PERFORMANCE REQUIREMENTS

#### DEEMED-TO-SATISFY PROVISIONS

Part

**NC1 Fire Resistance and Stability**

- NC1.1 Type of construction required
- NC1.2 Calculation of rise in storeys
- NC1.3 Mixed Types of Construction
- NC1.4 Open spectator stands and indoor sports stadiums.
- NC1.5 Lightweight construction
- NC1.6 Early Fire Hazard indices

**NC2 Compartmentation and Separation**

- NC2.1 Application
- NC2.2 General floor area limitations
- NC2.3 Large isolated buildings
- NC2.4 Requirements for open spaces and vehicular access
- NC2.5 Class 9a buildings
- NC2.6 Separation of openings in external walls
- NC2.7 Separation by fire walls
- NC2.8 Separation of classifications in the same storey
- NC2.9 Separation of classifications in different storeys
- NC2.10 Separation of lift shafts
- NC2.11 Stairways and lifts in one shaft
- NC2.12 Separation of equipment
- NC2.13 Electricity substations

**NC3 Protection of Openings**

- NC3.1 Application of Part
- NC3.2 Protection of openings in external walls
- NC3.3 Separation of openings in different fire compartments

Part

- NC3.4 Acceptable methods of protection
- NC3.5 Doorways in fire walls
- NC3.6 Sliding fire doors
- NC3.7 Protection of doorways in horizontal exits
- NC3.8 Openings in fire-isolated exits
- NC3.9 Service penetrations in fire-isolated exits
- NC3.10 Openings in fire-isolated lift shafts
- NC3.11 Bounding construction: Class 2,3 and 4 buildings
- NC3.12 Openings in floor for services
- NC3.13 Openings in shafts
- NC3.14 Openings for service installations
- NC3.15 Installation deemed-to-satisfy

**Specifications**

Specification NC1.1  
Fire-Resisting Construction

Specification NC1.5  
Structural Tests for Lightweight  
Construction

Specification NC1.6  
Early Fire Hazard Indices

Specification NC3.4  
Fire Doors, Smoke Doors, Fire Windows  
and Shutters

Specification NC3.15  
Penetration of Walls, Floors and Ceilings by  
Services

---

## PERFORMANCE REQUIREMENTS

### OBJECTIVES

The design and construction of buildings must fulfill the following objectives:-

#### NCP1 Fire Resistance and Stability

- (a) A building must be constructed so that it is protected from fire in any other building.
- (b) Materials used in the construction must be such that if there is a fire in the building;
  - (i) the spread of fire and the generation of smoke and toxic gases will be minimised;
  - (ii) stability will be maintained for a period at least sufficient for the occupants to escape and to ensure the safety of fire-fighters; and
  - (iii) there will be little risk of collapse onto adjoining property.

#### NCP2 Compartmentation and Separation

Buildings must be constructed to localise the effects of fire to the areas of origin. Adequate levels of passive fire protection must be provided so that sufficient time is available for the users and others to escape from the effects of fire and as an alternative, to allow the users to stay safely within unaffected compartments for the duration reasonably required to put out the fire by active means.

#### NCP3 Protection of Openings

Openings must be protected and service penetrations must be fire-stopped to maintain separation and compartmentation.

### REQUIRED PERFORMANCE

**NCP1.1** In order to maintain the *structural adequacy* and stability of any building for a sufficient time for the safety of the users fire fighters and others, the following must be ensured-

- (a) the *loadbearing* elements must have the FRL appropriate to their function in the building,

the expected fire load density, the fire risk, the height of the building, its location with reference to the availability of external fire fighting resources, and the fire control measures available within the building;

- (b) the FRL of structural elements must be at least equal to that of other elements to which they provide support; and
- (c) the collapse of elements with a lower FRL must not result in the collapse of elements with a higher FRL.

**NCP2.1** The size of a *fire compartment* must also be consistent with the fire severity of the fire load density it contains and the likely spread of fire between it and any other compartment, *storey* or building.

Building compartment size and separating construction must be such that the potential size of a fire and the spread of fire and smoke are limited in order to –

- (a) protect the occupants of one part of a building from the effects of fire elsewhere in the building;
- (b) control the spread of fire or smoke to adjoining buildings; and
- (c) facilitate access to the building by fire-fighters.

**NCP 3.1** Openings of any nature in the envelope surrounding *fire compartments* must be so protected that they do not allow the passage of dangerous amounts of heat, flames, smoke and gases in the event of a fire within or outside the compartment and for a period sufficient to-

- (a) allow the safe evacuation of all affected people; and
- (b) allow fire fighters to fight the fire.

The sufficiency of the duration allowed must take into account the nature of occupancy of the building as well as the proximity of other buildings and their occupancy.

## DEEMED-TO-SATISFY PROVISIONS

### FIRE RESISTANCE AND STABILITY

#### NC1.1 Type of Construction required

(a) The minimum Type of *fire-resisting construction* of a building must be that give in Table NC1.1, except as allowed for –

- (i) *open spectator* stands and indoor sports stadiums in NC1.4; and
- (ii) *lightweight* construction in NC1.5.

(b) Type A construction is the most fire-resistance and Type C the least fire-resistant of the Types of construction.

(ii) 2 storeys in any other case; and

(b) a storey is not counted if –

- (i) it is situated at the top of the building and contains only service units or equipment; or
- (ii) it is situated partly below the finished ground and the underside of the ceilings is not more than 1m above the average finished level of the ground at the *external wall*, or if the *external wall* is more than 12m long, the average for the 12m part where the ground is lowest.

TABLE NC1.1 TYPE OF CONSTRUCTION REQUIRED	
RISE (in storeys)	CLASS OF BUILDING OR PART
	2 3 4 5 6 7 8 9
5 OR MORE	A A A A A A A A
3 or 4	B B B B B B B B
1 or 2	C C C C C C C C
Note:	
1. See Specification NC1.1 for details of Types A, B and C construction.	

#### NC1.3 Mixed Types of construction

A building may be of mixed Types of construction if no part of the building is supported by, or vertically over, a part of less *fire-resisting* Type.

#### NC1.4 Open spectator stands and indoor sports stadiums

An *open spectator stand* or indoor sports stadium which has only changing rooms, sanitary facilities or the like below the tiered seating, need not comply with the other provision of this Part if it contains not more than 1 tier of seating and is of Type C and *non-combustible* construction.

#### NC1.5 Lightweight Construction

*Lightweight construction* must comply with Specification NC1.5 if it is used in construction which is *required* to be *fire-resisting*.

#### NC1.6 Early Fire Hazard Indices

The Early Fire Hazard Indices of materials and assemblies inside Class 2 to 9 buildings must comply with Specification NC1.6.

#### NC1.2 Calculation of rise in storeys

In calculating the *rise* in storeys –

(a) a storey that has an average internal height of more than 6m is counted as –

- (i) one storey if it is the only storey above the ground; or

## COMPARTMENTATION AND SEPARATION

### NC2.1 Application

This Part does not apply to an *open-deck carpark* or *open spectator stand*.

### NC2.2 General floor area limitations

- (a) The size of any *fire compartment* in a Class 5,6,7, 8 or 9b building must not exceed the relevant maximum *floor area* and volume set out in Table NC2.2 except as permitted in NC2.3.
- (b) A part of a building which contains only heating, ventilating, or lift equipment, water tanks, or similar service units is not counted in the *floor area* or volume of a *fire compartment* if it is situated at the top of the building.

TABLE NC2.2 MAXIMUM SIZE OF FIRE COMPARTMENTS				
	TYPE OF CONSTRUCTION OF BUILDING			
	TYPE A	TYPE B	TYPE C	
CLASS 5,6,7,8 or 9b	max <i>floor area</i> - 2000m <sup>2</sup>	1500m <sup>2</sup>	1000m <sup>2</sup>	max volume - 12000m <sup>3</sup>
	max volume - 12000m <sup>3</sup>	9000m <sup>3</sup>	6000m <sup>3</sup>	

**Note:** Subject to the requirements of table NE1.6 and if fully protected with a *sprinkler system* and water supply to NZS 4541 these areas and volumes of the *fire compartment* can be increased to a maximum of –

- (i) 8 times where the *sprinkler system* has two independent water supplies to Class A; and
- (ii) 4 times where the *sprinkler system* has a single water supply to Class C.
- (c) The size of any *fire compartment* in a Class 3 building must not exceed 600m<sup>2</sup> except if fully protected by a *sprinkler system* to any Class of water supply to NZS4541, this area may be increased to 1500m<sup>2</sup>.

### NC2.3 Large isolated buildings of Class 5,6,7,8 or 9b

The *floor area* of a *fire compartment* in a large isolated building may exceed that specified in Table NC2.2 to the following limits and conditions –

- (a) Up to 1800m<sup>2</sup> if –
  - (i) the building is Class 7 or 8, it contains not more than 2 *storeys* and an *open space* complying with NC2.4 (a) not less than 18m wide is provided around the building; or
  - (ii) the building is of any Class and is protected throughout with a *sprinkler system* and perimeter vehicular access complying with NC2.4 (b) is provided.
- (b) More than 1800 m<sup>2</sup> if –
  - (i) the building is protected throughout with a *sprinkler system* and perimeter vehicular access complying with NC2.4 (b) is provided;
  - (ii) if the ceiling height of the fire compartment is not more than 12m, it has a smoke exhaust system in accordance with specification NE2.6 or smoke-and-heat vents and the space below the roof is divided into compartments in accordance with AS 2665; and
  - (iii) if the ceiling height is more than 12 m, it has a smoke exhaust system in accordance with Specification NE2.6.
- (c) If more than one building is on the allotment–
  - (i) each building complies with (a) or (b); or
  - (ii) if the buildings are closer than 6m to each other and no building is more than 45m from the required vehicular access, they are regarded as one building and collectively comply with (a) or (b).

---

#### NC2.4 Requirements for open spaces and vehicular access

- (a) An *open space* required by NC2.3 must –
- (i) be wholly within the allotment except as in (iii);
  - (ii) include vehicular access in accordance with (b);
  - (iii) be next to the boundaries of the allotment, and may include any road, river, or public place adjoining the allotment;
  - (iv) not be used for the storage or processing of materials; and
  - (v) not be built upon, except for guard houses and services structures (such as substations and pump houses) which may encroach upon the width of the space if they do not unduly impede fire-fighting at any part of the perimeter of the allotment or unduly add to the risk of spread of fire to any building on an adjoining allotment.
- (b) The vehicular access *required* by this Part –
- (i) must be capable of providing emergency vehicle access and passage from the public road;
  - (ii) must have a minimum unobstructed width of 6m and in no part be built upon or used for any purpose other than vehicular or pedestrian movement;
  - (iii) may be substituted by a public road if the building faces and is accessible from the road, and is no further than 45m from it;
  - (iv) must be such that reasonable pedestrian access from the vehicular access to the building is available; and
  - (v) must be of adequate load bearing capacity and unobstructed height to permit the operation and passage of Fire Brigade vehicles.

#### NC2.5 Class 9a buildings

The building must be divided into *fire compartments* with a maximum *floor area* of 1700 m<sup>2</sup> and further –

- (a) *Ward areas* must be subdivided with walls of minimum FRL of 60/60/60 into *floor areas* of not more than 850 m<sup>2</sup> and again subdivided into parts of 425m<sup>2</sup> maximum *floor area* with smoke proof walls complying with (c);
- (b) other than *ward areas* must be subdivided into parts with a maximum *floor area* of 425m<sup>2</sup> with smoke proof walls complying with (c);
- (c) a wall *required* to be smoke-proof must –
  - (i) be *non-combustible* and extend to the underside of the floor above or of the roof covering;
  - (ii) only have doorways which are fitted with smoke doors complying with Specification NC3.4 and which do not extend higher than 800mm from the underside of an imperforate roof covering, floor or ceiling above it; and
  - (iii) not incorporate any other opening which is not smoke-proof; and
- (d) *Fire compartments* must be separated from the remainder of the building by *fire walls* and –
  - (i) in Type A construction – floors and roof or ceiling as *required* in Specification NC1.1;
  - (ii) in Type B construction – floors with a FRL of not less than 90/90/90, and if fully protected with a *sprinkler system* of 60/60/60; and
  - (iii) in Type C construction – floors with a FRL of not less than 60/60/60.

#### NC2.6 Separation of openings in external walls

In any building which is other than –

- fully protected with a *sprinkler system*;
- an *open deck car park*; or
- of one or two *storeys rise*,

if any part of a *window* or other opening in an *external wall* (except openings in the same stairway) is situated above another opening in the *storey* next below, the opening must be protected by –

- (a) a slab or other horizontal construction that-
- (i) projects outwards from the external face of the wall not less than 1100mm;
  - (ii) extends not less than 450 mm beyond the openings concerned; and
  - (iii) is of non-combustible material having a FRL not less than 60/60/60; or
- (b) a spandrel which –
- (i) is not less than 1100mm in height;
  - (ii) extends not less than 600mm above the upper surface of the intervening floor; and
  - (iii) is of *non-combustible* material having a FRL not less than 60/60.60; or
- (c) providing the *window* or opening in the upper *storey* with a glazing system with a FRL of not less than –/60/30. Any gap in the construction which separates the two *storeys* must be packed with a *non combustible* material that will withstand the relative thermal or structural movements of the walling and glazing without loss of seal.

**Note:** These requirements are separate from the structural requirements for glazing at B1.3 and B1.4.

#### NC2.7 Separation by fire walls

A part of a building separated from the remainder of the building by a *fire wall* is treated as a separate building if –

- (a) the *fire wall* –
  - (i) extends through all *storeys* and spaces in the nature of *storeys* that are common to that part and any adjoining part of the building;
  - (ii) is carried through to the underside of the roof covering; and
  - (iii) has the relevant FRL prescribed by Specification NC1.1 for each of the adjoining parts, and if these are different, the greater FRL;
- (b) any *openings* in a *fire wall* comply with Part NC3;

- (c) timber purlins or other *combustible* material do not pass through or cross the *fire wall*; and
- (d) where the roof of one of the adjoining parts is lower than the roof of the other part, the *fire wall* extends to the underside of –
  - (i) the covering of the higher roof, or not less than 6m above the covering of the lower roof;
  - (ii) the lower roof if it has a FRL not less than that of the *fire wall* and no openings closer than 3m to any wall above the lower roof;
  - (iii) the lower roof if its covering is *non-combustible* and the lower part has a *sprinkler system*; or
  - (iv) the design of the building must otherwise restrict the spread of fire from the lower part to the higher part.

#### NC2.8 Separation of classifications in the same storey

If a building has parts of different classifications located alongside one another in the same *storey* –

- (a) each building element in that *storey* must have the higher FRL prescribed in Specification NC1.1 for that element for the classifications concerned; or
- (b) the parts must be separated in that *storey* by a *fire wall* with whichever is the greater of the higher FRL prescribed in Specification NC1.1 for the classifications concerned.

#### NC2.9 Separation of classifications in different storeys

If parts of different classification are situated one above the other in adjoining *storeys* they must be separated as follows:

- (a) Type A or B construction – The floor between the adjoining parts must have a FRL not less than that prescribed in Specification NC1.1 for the classification of the lower *storey*.
- (b) Type C construction – The underside of the floor (including the sides and underside of any floor beams) must have a *fire-protective covering*.

---

### NC2.10 Separation of lift shafts

Any lift (other than if wholly in an *atrium*) must be separated from the remainder of the building by enclosure in a *shaft* with its FRL as prescribed by specification NC1.1 if it connects more than –

- (a) Two *storeys* in an unsprinklered building; or
- (b) Three *storeys* in a sprinklered building.

The openings for the lift landing doors and services must be protected in accordance with Part NC3.

### NC2.11 Stairways and lifts in one shaft

A stairway and lift must not be in the same *shaft* if either the stairway or the lift is *required* to be in a *fire-resisting shaft*.

### NC2.12 Separation of equipment

A wall having a FRL of not less than 60/60/60 must bound a room housing equipment comprising –

- (a) lift motors and lift control panels;
- (b) the main electrical switchboard in a building with an *effective height* of more than 25m;
- (c) *required* stair pressurizing equipment; or
- (d) boilers, emergency batteries, emergency generators or central smoke control plant, except –
  - (i) equipment located in a separate *storey* (or in the topmost *storey*) and separated from the remainder of the building by floor construction having a FRL of 60/60/60;

- (ii) smoke control exhaust fans located in the air stream if they are constructed for high temperature operation in accordance with Specification NE2.6; or
- (iii) equipment that is otherwise adequately separated from the remainder of the building.

### NC2.13 Electricity Substations

If an electricity substation is situated within a building–

- (a) it must be separated from any other part of the building by construction having a FRL of not less than 120/120/120.
- (b) doors windows and any other openings on an *external wall* need not have a FRL if such openings are no closer to a *fire source feature* or *exit* than 3m. Any other doorways including those opening to any other part of the building must be protected with *self-closing -/120/60* fire doors;
- (c) electricity supply cables between a main and the substation, and between the substation and the main switchboard, must be enclosed or otherwise protected by construction having a FRL of not less than 120/120/120; and
- (d) any openings, fans or grilles for natural or mechanical ventilation must be located only on an *external wall* unless protected with an *automatic -/120/60* fire shutter.



## PROTECTION OF OPENINGS

### NC3.1 Application of Part

- (a) This Part does not apply to –
- (i) control joints, weep holes, and the like, in masonry construction, and joints between pre-cast concrete panels, if they are not larger than necessary for the purpose; or
  - (ii) *non-combustible* ventilators for sub-floor or cavity ventilation, if each does not exceed 45x10<sup>3</sup> mm<sup>2</sup> in face area and is spaced not less than 2 m from any other ventilator in the same wall.
- (b) This Part applies to openings in building elements *required* to be fire-resisting, including doorways, *windows* (including any associated fanlight or infill panel) and other fixed or openable glazed areas that do not have the *required* FRL.

### NC3.2 Protection of openings in external walls

Openings in an *external wall* that is *required* to have a FRL must –

- (a) be not less distance from a *fire-source feature* to which it is exposed than –
- (i) 1m in a building not more than 1 *storey* in *rise*; or
  - (ii) 1.5m in a building more than 1 *storey* in *rise*;
- (b) be protected in accordance with NC3.4 if it is situated closer from a *fire-source feature* to which it is exposed than –
- (i) 3m from a side or rear boundary of the allotment;
  - (ii) 6m from the far boundary of a road adjoining the allotment; or
  - (iii) 6m from another building on the allotment that is not Class 10; and
- (c) if *required* to be protected under (b), not occupy more than 1/3 of the area of the *external wall* of the *storey* in which it is located unless –
- (i) they are in Class 9b building used as an *open spectator stand*; or

- (ii) they face a public road and are located in a *storey* at ground level.

### NC3.3 Separation of openings in different fire compartments

Unless they are protected in accordance with NC3.4, the distance between openings in *external walls* in compartments separated by a *fire wall* must not be less than that set out in Table NC3.3.

**TABLE NC3.3  
DISTANCE BETWEEN OPENINGS IN DIFFERENT COMPARTMENTS**

ANGLE BETWEEN WALLS	MINIMUM DISTANCE BETWEEN OPENINGS
0° (walls opposite) .....	6m
more than 0° to 45° .....	5m
more than 45° to 90° .....	4m
more than 90° to 135° .....	3m
more than 135° to 180° .....	2m

### NC3.4 Acceptable methods of protection

- (a) Where protection is *required*, doorways, *windows*, and other openings must be fitted with suitable –
- (i) **Doorways** - *-/60/30 self-closing* or *automatic* fire doors and fire shutters;
  - (ii) **Windows** - *-/60/30 fire windows (automatic* or permanently fixed in the closed position) or *-/60/30 automatic* fire shutters;
  - (iii) **Other openings** - construction having a FRL not less than *- /60/30*;

These methods of protection may be replaced with specifically engineered external drenches provided an adequate supply of water can be ensured.

- (b) Fire doors, smoke doors, fire windows and fire shutters satisfy (a) if they comply with Specification NC3.4

### NC3.5 Doorways in fire walls

The aggregate width of openings for doorways in a *fire wall* which are not part of a *horizontal exit* must not exceed ½ of the length of the *fire wall*, and each doorway must be protected by –

- (a) Two fire doors or fire shutters, one on each side of the doorway, each of which –
  - (i) has a FRL of not less than ½ that *required* by Specification NC1.1 for the *fire wall*; and
  - (ii) is *self-closing* unless provided with an *automatic* release mechanism for any hold-open device which will close the door upon actuation of any of the fire/smoke detection systems installed on both sides of the *fire wall*;
- (b) a fire door on one side and a fire shutter on the other side of the doorway, each of which complies with (a); or
- (c) a single fire door or a non metallic fire shutter, which –
  - (i) has a FRL of not less than that *required* by Specification NC1.1 for the *fire wall*; and
  - (ii) is *self-closing* unless provided with an *automatic* release mechanism for any hold open device which will close the door upon actuation of any of the fire-smoke detection systems installed on both sides of the *fire wall*.

### NC3.6 Sliding fire doors

If a doorway in a *fire wall* is fitted with a sliding fire door which is open when the building is in use –

- (a) it must be held open with a fusible link, or an electromagnetic device which when deactivated, allows the door to be fully closed not less than 20 seconds, and not more than 30 seconds, after release; and
- (b) thermal or smoke detectors as appropriate must be installed on each side of the doorway, in accordance with NZS 4232; and
- (c) an audible warning device located near the doorway and red flashing warning light of a suitable intensity on each side of the doorway must be activated when a *required*

detector or *sprinkler system* in the part of the building served by the door is activated; and

- (d) signs must be installed on each side of the doorway located directly over the opening stating –

#### “WARNING – SLIDING FIRE DOOR”

in capital letters not less than 50 mm high in a color contrasting with the background.

### NC3.7 Protection of doorways in horizontal exits

A doorway that is part of a *horizontal exit* must be protected-

- (a) in a Class 7 or 8 building – by 2 fire doors, one on each side of the doorway, each with a FRL of not less than ½ that *required* by Specification NC1.1 for the *fire wall*; or
- (b) in all classes of buildings, by a single fire door which has a FRL of not less than that *required* by Specification NC1.1 for the *fire wall*,

and each door must be *self-closing* or provided with *automatic* release of any hold-open device upon detection of smoke of fire.

### NC3.8 Openings in fire-isolated exits

- (a) A doorway that does not open to a road or *open space* must be protected by a *self-closing* or *automatic* -/60/30 fire door if it opens to a *fire-isolated stairway*, *fire-isolated passageway* or *fire-isolated ramp*.
- (b) A *window* in an *external wall* of a *fire-isolated stairway*, *fire-isolated passageway* or *fire-isolated ramp* must be protected in accordance with NC3.4 if it is within 6 m of, and exposed to –
  - (i) a *fire-source feature*; or
  - (ii) another *window* or other opening in a wall of the same building, unless they both serve the same fire-isolated enclosure.

### NC3.9 Service penetrations in fire-isolated exits

Fire-isolated *exits* must not be penetrated by any service other than –

- (a) electrical wiring associated with a lighting or pressurizing system servicing the *exit*;

- (b) ducting associated with the pressurizing system if it –
  - (i) is constructed of material having a FRL of not less than 60/60/60 where it passes through any other part of the building; and
  - (ii) does not open into any other part of the building; or
- (c) water supply pipes for the services or domestic use.

#### NC3.10 Openings in fire-isolated lift shafts

- (a) **Doorways** – If a lift *shaft* is *required* to be fire-isolated under Part NC2, an entrance doorway to that *shaft* must be protected by -/60/30 fire doors that –
  - (i) comply with AS1735.11; and
  - (ii) are set to remain closed except when discharging or receiving passengers, goods or vehicles.
- (b) **Lift Indicator panel** - A lift call panel, indicator panel or other panel in the wall of a fire-isolated lift *shaft* must be backed by construction having a FRL of not less than 60/60/60 if it exceeds 35 x 10<sup>3</sup>mm<sup>2</sup> in area.

#### NC3.11 Bounding construction: Class 2,3 and 4 buildings.

- (a) A doorway in a Class 2 or 3 building must be protected if it provides access from a *sole-occupancy unit* to –
  - (i) a *public corridor*, public hallway, or the like;
  - (ii) a room not within a *sole-occupancy unit*;
  - (iii) the landing of an internal non-*fire-isolated stairway* that serves as a *required exit*; or
  - (iv) another *sole-occupancy unit*.
- (b) A doorway in a Class 4 part must be protected if it provides access to any other internal part of the building.
- (c) Protection for a doorway must be at least –
  - (i) in a building of Type A or B construction – a *self-closing* - /30/30 fire door; and

- (ii) in a building to Type C construction – a *self-closing* tight fitting solid core door not less than 35mm thick in a rebated frame.
- (d) Other openings in *internal walls* which are *required* to have a FRL to inhibit the lateral spread of fire must not reduce the *fire-resisting* performance of the wall.

#### NC3.12 Openings in floors for services

In a building of Type A and B construction, services associated with the functioning of the building and passing through a floor must either be installed in *shafts* complying with Specification NC1.1 or protected in accordance with NC3.14.

#### NC3.13 Openings in shafts

In a building of Type A or B construction, an opening in a wall providing access to a ventilating, pipe, garbage or other service *shaft* must be protected by –

- (a) if it is in a *sanitary compartment* – a door or panel which, together with its frame, has FRL of not less than -/30/-; or
- (b) a *self-closing* -/30/- fire door or hopper; or
- (c) an access panel having a FRL or not less than -/30/-.

#### NC3.14 Openings for service installations

An electrical, electronic, plumbing, mechanical ventilation or air-conditioning, or other service that penetrates a building element (other than an *external wall* or roof) that is *required* to have a FRL or a *resistance to the incipient spread of fire*, must be installed so that the *fire-resisting* performance of the building element is not impaired.

#### NC3.15 Installation deemed-to-satisfy

Installation satisfies NC3.14 if –

- (a) the method and materials used are identical with a prototype assembly of the service and building element which has achieved the *required* FRL or *resistance to the incipient spread of fire*;
- (b) it complies with (a) except for the *insulation* criterion relating to the service when –
  - (i) the service is farther than 100mm from any *combustible* material; and
  - (ii) it is not located in a *required exit*;

- 
- (c) in the case of ventilating or air-conditioning ducts or equipment the installation is in accordance with AS/NZS 1668.1;
- (d) the service is a metal pipe installed in accordance with Specification NC3.15 and it penetrates a wall, floor or ceiling, but not a ceiling *required to have a resistance to the incipient spread of fire*;
- (e) the service is sanitary plumbing installed in accordance with Specification NC3.15 and it –
- (i) is of metal or UPVC pipe; and
  - (ii) penetrates the floors of a Class 5,6,7,8 or 9b building; and
- (iii) is in *sanitary compartments* which are separated from other parts of the building by walls with the FRL *required* by Specification NC1.1 for a stair *shaft* in the building and a *self-closing -/60/30* fire door;
- (f) the service is a wire or cable, or a cluster of wires or cables installed in accordance with Specification NC3.15 and it penetrates a wall, floor or ceiling, but not a ceiling *required to have a resistance to the incipient spread of fire*; or
- (g) the service is an electrical switch, outlet, or the like, and it is installed in accordance with Specification NC3.15.
-

---

## FIRE-RESISTING CONSTRUCTION

### 1. SCOPE

This Specification contains requirements for the *fire-resisting* construction of building elements.

### 2. GENERAL REQUIREMENTS

#### 2.1 Exposure to fire-source features

(a) A part of a building element is exposed to a *fire-source feature* if there is no obstruction to any horizontal line between that part and the *fire-source feature* or a vertical projection of the feature. Where another part of the building obstructs any such horizontal line, the part under consideration will still be considered exposed if the obstruction has –

- (i) a FRL of not less than 30/-/-; or
- (ii) is transparent or translucent

(b) A part of a building element is not exposed to a *fire-source feature* if the *fire-source feature* is –

- (i) an *external wall* of another building that stands on the allotment and the part concerned is more than 15m above the highest part of that *external wall*; or
- (ii) a side or rear boundary of the allotment and the part concerned is below the level of the finished ground at every relevant part of the boundary concerned.

(c) If various distances apply for different parts of a building element –

- (i) the entire element must have the FRL applicable to that part having the least distance between itself and the relevant *fire-source feature*; or
- (ii) each part of the element must have the FRL applicable according to its individual distance from the relevant *fire-source feature*;

but this provision does not override or permit any exemption from Clause 2.2.

#### 2.2 Fire protection for a support of another part

A part of a building that gives direct vertical or lateral support to another part *required* to have a FRL, must have a FRL in respect of *structural adequacy* not less than the greater of –

- (a) that *required* for the part it supports; or
- (b) that *required* for the part itself,

and be *non-combustible* if the part it supports is *required* to be *non-combustible*.

#### 2.3 Lintels

A lintel must have the FRL *required* for the part of building in which it is situated. It need not have the FRL if it does not contribute to the support of a fire door, fire *window* or fire shutter, and –

- (a) it spans an opening in –
  - (i) a wall of a building containing only one *storey*;
  - (ii) a *non-loadbearing* wall of a Class 2 or 3 building; or
- (b) it spans an opening in masonry which is not more than 150mm thick and –
  - (i) not more than 3m wide if the masonry is *non loadbearing*; or
  - (ii) not more than 1.8m wide if the masonry is *loadbearing* and part of one of the leaves of a cavity wall.

#### 2.4 Attachments not to Impair fire-resistance

(a) A *combustible* material may be used as a finish or lining to a wall or roof, or in a sign, sunscreen or blind, awning, or other attachment to a building element which has the *required* FRL if –

- (i) the material is exempt under clause 7 of Specification NC1.6 or complies with the Early Fire Hazard Indices prescribed in clause 2 of the same Specification.
- (ii) it is not located near or directly above a *required exit* so as to make the *exit* unusable in a fire; and

- (iii) it does not otherwise constitute an undue risk of fire spread via the façade of the building.
- (b) The attachment of a facing or finish, or the installation of ducting or any other service, to a part of a building *required* to have a FRL must not impair the *required* FRL of that part.

## 2.5 General concessions

- (a) Steel columns – Except in a *fire wall* or *common wall*, a steel column need not have a FRL in a building that contains only one *storey*.
- (b) Timber Columns – In a building that contains only one storey a timber column may be used provided:
  - (i) in a *fire wall* or *common wall* the column has the required FRL.
  - (ii) in all other cases, the column has a FRL of not less than 30/-/-.
- (c) Structures on roofs – A *non-combustible* structure situated on a roof need not comply with the other provision of this Specification if it only contains one or more of the following:
  - (i) Hot water or other water tanks.
  - (ii) Ventilating ductwork, ventilating fans and their motors.
  - (iii) Air-conditioning chillers
  - (iv) *Window* cleaning equipment.
  - (v) Lift equipment.
  - (vi) Other service units that are *non-combustible* and do not contain *combustible* fluids.

## 3. TYPE A FIRE-RESISTING CONSTRUCTION.

### 3.1 Fire-resistance of building elements

In a building *required* to be of Type A construction –

- (a) each part mentioned in Table 3, and any beam or column in it, must have a FRL not less than that listed in the Table, for the particular Class of building concerned;
- (b) *external walls*, *common walls* and floors must be *non-combustible*;

- (c) any *internal wall* required to have a FRL must extend to –
  - (i) the underside of the floor next above;
  - (ii) the underside of a roof complying with Table 3; or
  - (iii) a ceiling which is immediately below the roof and has a *resistance to the incipient spread of fire* to the roof space of 60 minutes;
- (d) (i) an *internal wall* required to be *fire-resisting*; and
  - (ii) ventilating, pipe, garbage, or similar *shaft* that is not for the discharge of hot products of combustion, must be of *non-combustible* construction and if of *lightweight* construction comply with Specification NC1.5;
- (e) any flooring and floor framing in a lift pit must be *non-combustible*; and
- (f) the FRLs specified in Table 3 for an external column apply also to those parts of an internal column that face and are within 1.5m or a *window* and are exposed through that *window* to a *fire-source feature*.

### 3.2 Concessions for floors

The following floors need not comply with clause 3.1;

- (a) A floor laid directly on the ground.
- (b) In a Class 2,3 5 or 9 building if the space below is not a storey, does not accommodate motor vehicles, is not a storage or work area, and is not used for any other ancillary purpose.
- (c) It is a timber stage floor in a Class 9b building laid over a floor having the *required* FRL if the space below the stage is not used as a dressing room, store room, or the like.
- (d) It separates 2 *storey* within the same *sole-occupancy unit* in a Class 2 building.

---

**3.3 Floor loading of Class 5 and 9b buildings: Concession**

If a floor in a Class 5 or 9b building is designed for a live load not exceeding 3kP-

- (a) the floor next above (including floor beams) may have a FRL or 90/90/90; or
- (b) the roof, if that is next above (including roof beams) may have a FRL 90/60/30.

**3.4 Roof superimposed on concrete slab: Concession**

A roof not complying with clause 3.1 as to *fire-resisting construction* may be superimposed on a concrete slab roof if –

- (a) the superimposed roof and any construction between it and the concrete slab roof are *non-combustible* throughout; and
  - (b) the concrete slab roof complies with Table 3.
-

<b>TABLE 3 TYPE A CONSTRUCTION: FRL OF BUILDING ELEMENTS</b>		
<b>BUILDING ELEMENT</b>	<b>FRL: (in minutes)</b> <i>Structural Adequacy / Integrity / Insulation</i>	
	<b>CLASS OF BUILDING</b>	
	2, 3 or 4 part	5, 6, 7, 8, or 9
<b>EXTERNAL WALL</b> or other external building element excluding a roof, where the distance from any <i>fire-source feature</i> to which it is exposed is –		
For <i>loadbearing</i> parts -		
Less than 1.5m	90/90/90	120 /120/120
1.5 to less than 3m	90/60/60	120/90/90
3 or more	90/60/30	120/60/30
For <i>non-loadbearing</i> parts -		
Less than 1.5m	90/90/0	120/120/120
1.5 to less than 3m	90/60/60	120/90/90
3m or more	- / - / -	- / - / -
<b>EXTERNAL COLUMN</b> not incorporated in an <i>external wall</i> , where the distance from any <i>fire-source feature</i> to which it is exposed is -		
Less than 3 m	90 / - / -	120/ - / -
3m or more	- / - / -	- / - / -
<b>COMMON WALLS AND FIRE WALLS -</b>	90 / 90 / 90	120/120/120
<b>INTERNAL WALLS -</b>		
Fire-resisting lift or stair <i>shafts</i> -		
<i>Loadbearing</i>	90/90/90	90/90/90
<i>Non-loadbearing</i>	90/90/90	90/90/90
Bounding <i>public corridor</i> , public hallways and the like -		
<i>Loadbearing</i>	90/90/90	90/ - / -
<i>Non-loadbearing</i>	60/60/60	- / - / -
Between or bounding <i>sole-occupancy units</i> -		
<i>Loadbearing</i>	90/90/90	90/-/-
<i>Non-loadbearing</i>	60/60/60	- / - / -
Ventilating, pipe, garbage, and like <i>shafts</i> not used for the discharge of hot products of combustion -		
<i>Loadbearing</i>	90/90/90	90/90/90
<i>Non-loadbearing</i>	90/90/90	90/90/90
<b>OTHER LOADBEARING INTERNAL WALLS; and INTERNAL BEAMS, TRUSSES and COLUMNS</b>	- 90/ - / -	90/ - / -
<b>FLOORS</b>	90/90/90	120/120/120
<b>ROOFS</b>	90/60/30	120/60/30
<b>MAIN ROOF BEAMS</b>	90/ - / -	120/ - / -



### 3.5 Roofs: Concession

A roof need not comply with Table 3 if –

- (a) in other than a Class 2 or 3 building –
  - (i) it has an *effective height* of not more than 25m and the roof covering and its supporting members are of *non-combustible* construction; or
  - (ii) the ceiling immediately below the roof has a resistance to the *incipient spread of fire* to the roof space of not less than 60 minutes; or
  - (iii) the building has a *non-combustible* roof covering and the *storey* immediately below the roof has an *automatic sprinkler system* installed throughout; or
- (b) in a Class 2 or 3 building –
  - (i) all *internal walls* bounding the *sole-occupancy* units on the topmost *storey* extend to the underside of a *non-combustible* roof covering; or
  - (ii) the *sole-occupancy unit* is the only unit in that *storey*.

### 3.6 Rooflights

If a roof is *required* to have a FRL or be *non-combustible*, a rooflight installed in that roof must –

- (a) have an area not more than 20% of roof surface;
- (b) be not less 3m from –
  - (i) any boundary of the allotment other than the boundary with a road or public place;
  - (ii) any part of the building which projects above the roof unless that part has the FRL *required* of a *fire wall* and any openings in the wall

are protected in accordance with NC3.14;

- (iii) any rooflight in an adjoining *sole-occupancy unit* if the walls bounding the unit are *required* to have a FRL; and
- (iv) any rooflight in an adjoining fire-separated section of the building; and

- (c) be installed in a way that will maintain the level of protection to the roof space provided by a *required* ceiling with a *resistance to the incipient spread of fire*.

### 3.7 Internal columns and walls: Concession

If under Clause 3.5 a roof that does not have a FRL is used in a building with an *effective height* of not more than 25m, internal columns which are not those referred to in clause 3.1 (f) and *loadbearing internal walls* which are not *fire walls*, in the *storey* immediately below that roof may have a FRL of 60/60.60.

### 3.8 Open spectator stands and indoor sports stadiums: Concession

In an *open spectator stand* or indoor sports stadium, the following building elements need not have the FRL specified in Table 3:

- (a) The roof if it is *non-combustible*.
- (b) Columns and *loadbearing* walls supporting only the roof they are *non-combustible*.
- (c) any non-*loadbearing* part of an *external wall* less than 3 m –
  - (i) from any *fire-source feature* to which it is exposed if it has a FRL of not less than 60/60/60 and is *non-combustible*; or
  - (ii) from an *external wall* of another *open spectator stand* if it is *non-combustible*.

### 3.9 Carpark: Concessions

The FRLs in Table 3.9 apply to a carpark instead of those at Table 3.

TABLE 3.9 FRL FOR CARPARKS	
BUILDING ELEMENT	FRL
<b>Column or beam</b> – less than 4.5m from a <i>fire-source feature</i> to which it is exposed	60/ - / -
<b>Wall</b> – less than 3m from a <i>fire-source feature</i> to which it is exposed	60/60/60
<b>Other steel column</b> – ratio of exposed surface area to mass per unit length not greater than 26m <sup>2</sup> /tonne	- / - / -
<b>Any other column</b> (other than supporting only the roof)	60/ - / -
<b>Fire wall or lift or stair shaft</b>	90/90/90
<b>Any other steel floor beam</b> – which is in continuous contact with a concrete floor slab and has a ratio of exposed surface area to mass per unit length not more than 30m <sup>2</sup> /tonne	- / - / -
<b>Any other floor beam</b>	60/ - / -
<b>Floor slab or vehicle ramp</b>	60/60/60
<b>Roof and columns supporting only the roof</b>	- / - / -

### 3.10 Mezzanine floors: Concession

Except in a Class 9b building which is a spectator viewing area that accommodates more than 100 persons under ND1.13, *mezzanine floors* and any supporting building elements need not have a FRL or be *non-combustible* if every wall or column that supports any part of the building other than the *mezzanine floor* or floors within 6m of a *mezzanine floor* as its FRL increased from that otherwise *required*, as set out in Table 3.10.

**TABLE 3.10  
INCREASED FRLs – CONSTRUCTION  
SURROUNDING MEZZANINES**

LEVEL OTHERWISE INCREASE IN LEVEL  
REQUIRED FOR ANY TO (not less than):  
FRL CRITERION (mins)

30	“	“	“	“	60
90	“	“	“	“	120

The increase in level applies to each FRL criterion (*structural adequacy, integrity or insulation*) relevant to the building element concerned.

### 3.11 Sprinklers: Concession

Each of the three criteria of the FRL otherwise *required* under Tables 3 and 3.9 may be reduced by 30 minutes if the building is fully protected with a *sprinkler system*.

## 4. TYPE B FIRE-RESISTING CONSTRUCTION

### 4.1 Fire-resistance of building elements

In a building *required* to be of Type B construction –

- (a) each part mentioned in Table 4, and any beam or column in it, must have a FRL not less than that listed in the Table for the particular Class of building concerned;
- (b) a *common wall*, the flooring and floor framing in any lift pit, and an *external wall* where a FRL is listed in table 4, must be *non-combustible*;
- (c) if a stair *shaft* supports any floor or a structural part of it –
  - (i) the floor or part must have a FRL of 60/-/ or more; or
  - (ii) the junction of the stair *shaft* must be constructed so that the floor or part will be free to sag or fall in a fire without causing structural damage to the *shaft*,
- (d) any *internal wall* which is *required* to have a FRL must extend to –
  - (i) the underside of the floor next above;

- 
- (ii) the underside of a ceiling having a *resistance to the incipient spread of fire* to the space above itself of not less than 60 minutes; or
- (iii) the underside of the roof covering if it is *non-combustible*, or 450mm above the roof covering if it is *combustible*, and must not be crossed by timber purlins or other *combustible* material,
- unless the wall bounds a *sole-occupancy* unit in the topmost (or only) *storey* and there is only one *unit* in that *storey*;
- (e) an *internal wall* required to be *fire-resisting* must be of *non-combustible* construction, and if it is of *lightweight construction*, it must comply with Specification NC1.5;
- (f) lift, ventilation, pipe, garbage, and similar *shaft* which are not for the discharge of hot products of combustion and not *loadbearing*, must be of *non-combustible* construction in Class 2 to 9 buildings; and
- (g) all *external walls* and *fire walls* within 1.5m of the boundary, excluding a boundary adjoining a public road or stream or other open water channel, must be extended to not less than 450mm above the adjoining roof line to form a parapet.

**TABLE 4  
TYPE B CONSTRUCTION : FRL OF BUILDING ELEMENTS**

<b>BUILDING ELEMENT</b>	<b>FRL: (in minutes)</b> <i>Structural Adequacy/Integrity/Insulation</i>	
	<b>CLASS OF BUILDING</b> <b>2,3 or 4 part</b>	<b>5,6,7,8 or 9</b>
<b>EXTERNAL WALL</b> or other external building element excluding a roof, where the distance from any <i>fire-source feature</i> to which it is exposed is -		
For <i>loadbearing</i> parts -		
Less than 1.5m	60/60/60	90/90/90
1.5 to less than 3m	60/60/30	90/90/60
3 to less than 9m	60/30/ -	90/30/30
9.0 to less than 18m	60/ - / -	90/30/-
For <i>non-loadbearing</i> parts -		
Less than 1.5m	60/60/60	90/90/90
1.5 to less than 3m	60/60/30	90/90/60
3m or more	- / - / -	- / - / -
<b>EXTERNAL COLUMN</b> not incorporated in an <i>external wall</i> , where the distance from any <i>fire-source feature</i> to which it is exposed is -		
Less than 3m	60/ - / -	90/ - / -
3 m or more	- / - / -	- / - / -
<b>COMMON WALLS AND FIRE WALLS</b>	60/60/60	90/90/90
<b>INTERNAL WALLS –</b>		
Fire-resisting lift or stair <i>shafts</i> -		
<i>Loadbearing</i>	60/60/60	60/60/60
<i>Non-loadbearing</i>	60/60/60	60/60/60
Bounding <i>public corridors</i> , public hallways and the like -		
<i>Loadbearing</i>	60/60/60	60/-/-
<i>Non-loadbearing</i>	60/60/60	- / - / -
Between or bounding <i>sole-occupancy units</i> -		
<i>Loadbearing</i>	60/60/60	60/ - / -
<i>Non-loadbearing</i>	60/60/60	- / - / -
<b>OTHER LOADBEARING INTERNAL WALLS and COLUMNS</b>		
	60/ - / -	60/ - / -
<b>FLOORS*</b>	60/30/30	60/60/60
<b>MAIN ROOF BEAMS</b>	60/ - / -	60/ - / -
*See NC2.5 (d) for Class 9a buildings		

#### 4.2 Carparks: Concessions

The FRLs in Table 4.2 apply to a carpark instead of those at Table 4.

TABLE 4.2 FRL FOR CARPARKS	
BUILDING ELEMENT	FRL
<b>Column or beam</b> – less than 4.5m from a <i>fire-source</i> to which it is exposed .. .. .	60/-/-
<b>Wall</b> – less than 3m from a <i>fire-source feature</i> to which it is exposed .. .. .	60/60/60
<b>Other steel column</b> – ratio of exposed surface area to mass per unit length not greater than 26m <sup>2</sup> /tonne .. .. .	-/-/-
<b>Any other column</b> .. .. .	60/-/-
<b>Fire wall or lift or stair shaft</b> .. .. .	60/60/60
<b>Any other steel floor beam</b> – which is in continuous contact with a concrete floor slab and has a per unit length not more than 30m <sup>2</sup> /tonne .. .. .	-/-/-
<b>Any other floor beam</b> .. .. .	60/-/-

#### 4.3 Sprinklers: Concession

Each of the three criteria of the FRL otherwise *required* under Tables 4 and 4.2 may be reduced by 30 minutes if the building is fully protected with a *sprinkler system*.

### 5. TYPE C FIRE-RESISTING CONSTRUCTION

#### 5.1 Fire-resistance of building elements

In a building *required* to be of type C construction –

- (a) A building element listed in Table 5, and any beam or column incorporated in it, must have a FRL not less than that listed in the Table for the particular Class of building concerned.
- (b) An *external wall* that is *required* by Table 5 to have a FRL may be considered to have a FRL if the outer part of the wall has the *required* FRL.
- (c) A *fire wall* or an *internal wall* bounding a *sole occupancy* unit or separating adjoining units, if it is of *lightweight construction* must comply with Specification NC1.5.
- (d) In a Class 2 or 3 building an *internal wall* which is *required* by Table 5 to have a FRL must extend –
  - (i) to the underside of the floor next above if that floor has a FRL of at least 30/30/30 or to a *fire protective covering* on the underside of the floor;
  - (ii) to the underside of a ceiling having a *resistance to the incipient spread of fire* to the space above itself of not less than 60 minutes; or
  - (iii) to the underside of the roof covering if it is *non-combustible*, or 450mm above the adjoining roof covering if it is *combustible*, and must not be crossed by timber purlins or other *combustible* material.

unless the wall bounds a *sole-occupancy unit* in the topmost (or only) *storey* and there is only one unit in that *storey*.
- (e) All *external walls* and *fire walls* within 1.5m of the boundary, excluding a boundary adjoining a public road or stream or other open water channel, must be extended to not less than 450mm above the adjoining roof line to form a parapet.

<b>TABLE 5 TYPE C CONSTRUCTION: FRL OF BUILDING ELEMENTS</b>			
<b>BUILDING ELEMENT</b>	<b>FRL: (in minutes)</b> <i>Structural Adequacy / Integrity / Insulation</i>		
	<b>CLASS OF BUILDING</b>		
	2	3 or 4 part	5,6,7,8 or 9
<b>EXTERNAL WALL</b> or other external building element excluding a roof, where the distance from any <i>fire-source feature</i> to which it is exposed is -			
Less than 1.5m	60/60/60	60/60/60	60/60/60
<b>EXTERNAL COLUMN</b> not incorporated in an <i>external wall</i> , where the distance from any <i>fire-source feature</i> to which it is exposed is -			
Less than 1.5m	60/ - / -	60/ - / -	60/ - / -
<b>COLUMN WALLS AND FIRE WALLS:</b>	60/60/60	60/60/60	60/60/60
<b>INTERNAL WALLS -</b>			
Bounding <i>public corridors</i> , public hallways and the like	30/30/30	60/60/60	- / - / -
Between or bounding <i>sole-occupancy units</i>	30/30/30	60/60/60	- / - / -
Bounding a stair if <i>required</i> to be rated	30/30/30	60/60/60	- / - / -
<b>Note:</b> See NC2.5(d) for floors of class 9a buildings.			

## 5.2 Carparks: Concessions

The FRLs in Table 5.2 apply to a carpark instead of those at Table 5.

<b>TABLE 5.2 FRLs FOR CARPARKS</b>	
<b>BUILDING ELEMENT</b>	<b>FRL</b>
<b>Column or beam</b> – less than 1.5m from a <i>fire-source feature</i> to which it is exposed. . . . .	60/ - / -
<b>Wall</b> – less than 1.5m from a <i>fire-source feature</i> to which it is exposed	60/60/60
<b>Other steel column</b> – ratio of exposed surface area to mass per unit length of greater than 26m <sup>2</sup> /tonne	- / - / -
<b>Any other column</b>	60 / - / -
<b>Any other steel floor beam</b> – which is in continuous contact with a concrete floor slab and has a ratio of exposed surface area to mass per unit length not more than 30m <sup>2</sup> /tonne	- / - / -
<b>Any other floor beam</b>	60 / - / -

---

## STRUCTURAL TESTS FOR LIGHTWEIGHT CONSTRUCTION

### 1. Scope

This Specification contains the tests to be applied and criteria to be satisfied by *lightweight construction*.

E72-80, except that the chamber method must not be used.

### 2. Definition

*Lightweight construction* is –

(a) *fire-resisting construction* which –

- (i) is not in continuous contact with the principal construction that it protects from fire; or
- (ii) is of sheet or board material, plaster, render, sprayed application, or other material similarly susceptible to damage by pressure or abrasion;

(b) *fire-resisting construction* which incorporates or comprises –

- (i) concrete containing pumice, perlite, vermiculite, or other soft material; or
- (ii) masonry having a thickness less than 70mm.

### 3. Application

The tests prescribed in this specification apply to construction other than concrete or masonry which need not be tested in accordance with this specification if it is designed –

- (a) in accordance with this Code; and
- (b) to resist, as serviceability loads, the appropriate pressure and impact defined in this Specification.

### 4. Test methods

Tests must be carried out in accordance with the following:

- (a) **Materials tests** – in accordance with the methods specified for the constituent materials of construction in the Standards adopted by reference in this Code.
- (b) **For resistance to static pressure** – The provisions for testing walls under transverse load in ASTM

(i) the load must be applied dynamically at a frequency not less than 1 Hz and not more than 3 Hz; and

(ii) it is sufficient to test one specimen with the pressure applied from the side of the construction on which the lift will operate.

(c) **For resistance to Impact** – The provisions for testing wall systems in ASTM E695-79 (1985), except that –

(i) the points of impact must be set at 1.5m above finished floor level or 1.5m above the part of the specimen that corresponds to finished floor level; and

(ii) the diameter of the impact bag must be between 225mm and 260mm and the bag must weigh 27.2 + 0.1 Kg;

(iii) the mass must be achieved by putting loose, dry sand into the bag and must be adjusted before each series of impact tests; and

(iv) the method may be used also for wall that depart from the vertical or that are curved and in cases where the pendulum bag and suspension cannot be vertical at the instant of impact on a concave surface or a surface inclined towards the impact, the height of drop is the net height at the point of impact.

(d) **For resistance to surface indentation** – for all materials irrespective of composition: AS 2185.

(e) **For resistance of lift shaft construction to repetitive load** – as for 3 (b) except that–

(i) the load must be applied dynamically at a frequency not less than 1 Hz and not more than 3 Hz; and

(ii) it is sufficient to test one specimen with the pressure applied from the

---

side of the construction on which  
the lift will operate.



---

## 5. Test specimens

Tests must be carried out on construction in situ or on specimens of the construction in accordance with clause 4 except that –

- (a) test specimens of the construction must be supported at top and bottom (or at each end if tested horizontally by components identical with, and in a manner identical with, the actual construction; and
- (b) the heights of the test specimens (or lengths, if the specimens are tested horizontally) must be identical with the height between those supports in the actual construction.

## 6. Criteria of compliance

The following criteria must be adopted to determine compliance with the specification:

- (a) **Material** – Must comply with the applicable Standard adopted by reference in this Code.
- (b) **Damage** – The construction must show no crack, penetration or permanent surface-deformation to a depth of more than 0.5mm nor must there be any other non-elastic deformation nor fastener failure.
- (c) **Deflection – Static pressure** - Under static pressure the deflection of the construction must not be more than –
  - (i)  $1/240^{\text{th}}$  of the height between supports (the span of the construction as tested);
  - (ii) 30mm; or
  - (iii) 20mm for lift *shafts* unless the requirements of Clause 15.2(a) of AS1735.2 are fulfilled.
- (d) **Deflection - Impact** - Under impact the instantaneous deflection of the construction must not be more than –
  - (i)  $1/120^{\text{th}}$  of the height between supports (the span of the construction as tested);
  - (ii) 30mm; or
  - (iii) 20mm for lift *shafts* unless the requirements of /clause 15.2(a) pf AS1735.2 are fulfilled.

- (e) **Surface indentation (AS 2185)** – No impression must be more than 5mm in diameter.

## 7. Wall systems

Wall systems that are *required* to be *fire resisting* bounding *public corridors*, public hallways and the like, and between or bounding *sole-occupancy units* must be subjected to the following tests and must fulfill the following criteria:

- (a) The materials tests of clause 4(a) and the materials properties criteria of clause 6 (a)
- (b) A static test by the imposition of a uniformly distributed load (or its equivalent) of 0.25kPa in accordance with clause 4(b) and the damage and deflection criteria of clauses 6(b) and (c) respectively.
- (c) A dynamic test by the imposition of the impact of the impact bag falling through a height of 100 mm in accordance with clause 4(c) and the damage and deflection criteria of clause 6(b) and (d) respectively.
- (d) The surface indentation test of clause 4(d) and the surface indentation criterion of clause 6(e).

## 8. Construction bounding means of egress

Construction bounding means of egress including wall systems for use in-lift *shafts*, stair *shafts*, *fire-isolated passageways* and *fire-isolated ramps* that are *required* to be *fire-resisting* must be subjected to the following tests and must fulfill the following criteria:

- (a) The materials tests of clause 4(a) and the materials properties criteria of clause 6(a).
- (b) A static test by the imposition of a uniformly distributed load (or its equivalent) or 0.35 kPa in accordance with clause 4 (b) and the damage and deflection criteria of clauses 6(b) and (c) respectively.
- (c) A dynamic test with the impact bag falling through a height of 150mm in accordance with clause 3(c) and the damage and deflection criteria of clause 6(b) and (d) respectively.
- (d) The surface indentation test of clause 4(d) and the surface indentation criterion of clause 6(e).

---

## 9. Requirements for certain Class 9b buildings.

Wall systems for use in spectator stands, sports stadia, cinemas or theatres, railway or bus station, or airport terminals in –

- (a) lift *shafts* or stair *shafts*;
- (b) external and *internal walls* bounding *public corridors*, public hallways and the like, including fire-isolated and non-*fire-isolated passageways* or ramps,

must be subjected to the following tests and must fulfill the following criteria;

- (i) The materials tests of clause 4 (a) and the materials properties criteria of clause 6(a).
- (ii) A static test by the imposition of a uniformly distributed load (or its equivalent) of 1.0kPa in accordance with Clause 4(b) and the damage and deflection criteria of clauses 6(b) and (c) respectively.
- (iii) A dynamic test with the impact bag falling through a height of 350 mm in accordance with Clause 4(c) and the damage and deflection criteria of clauses 6(b) and (d) respectively.
- (iv) The surface indentation test of clause 4(d) and the criterion of clause 6(e).

## 10. Lift Shafts

In addition to the requirements of clauses 8 and 9, *wall systems* for use in lift *shafts* that are *required* to be *fire-resisting* must be subjected to dynamic test by the imposition of  $10^6$  cycles of a uniformly distributed load (or its equivalent) between 0 and 0.35kPa in accordance with clause 4(e) and must fulfill the damage criteria of clause 6(b).

---

## EARLY FIRE HAZARD INDICES

### 1. Scope

This Specification sets out requirements in relation to the Early Fire Hazard Indices of materials, linings and surface finishes inside buildings.

### 2. Class 2 to 9 buildings: General requirements

Except where superseded by clause 3 or 4, any material or component used in a Class 2,3,5,6,7,8 or 9 building must

- (a) in the case of a *sarking-type material*, have a *Flammability Index* not more than 5;
- (b) in the case of other materials, have –
  - (i) a *Spread-of-Flame Index* not more than 9; and
  - (ii) a *Smoke-Developed Index* not more than 8 if the *Spread-of-Flame Index* is more than 5;
- (c) be completely covered on all faces by concrete or masonry not less than 50mm thick; or
- (d) in the case of a composite member or assembly, be constructed so that when assembled as proposed in a building –
  - (i) any material which does not comply with (a) or (b) is protected on all sides and edges from exposure to the air;
  - (ii) the member or assembly, when tested in accordance with Specification A2.4, has a *Smoke-Developed Index* and a *Spread-of-Flame Index* not exceeding those prescribed in (b); and
  - (iii) the member or assembly retains the protection in position so that it prevents ignition of the material and continues to screen it from access to free air for a period of not less than 10 minutes.

### 3. Fire-isolated exits

In a *fire-isolate stairway*, *fire-isolated passageway*, or *fire-isolated ramp* in a Class 2 to 9 building –

- (a) a *material*, other than a *sarking-type material*, used in a ceiling, as an attachment to a *structural member* or as the finish, surface or lining of a *structural member* must –
  - (i) have a *Spread-of-Flame Index* of 0;
  - (iii) have a *Smoke-Developed Index* of not more than 2; and
  - (iv) if *combustible*, be attached directly to a *non-combustible* substrate and not exceed 1mm in finished thickness;
- (b) a *sarking-type material* used in the form of an exposed wall or ceiling, or as a finish or attachment thereto, must have a *Flammability Index* of 0.

### 4. Class 2,3 and 9 buildings: Public areas

A material other than a *sarking-type material* must have a *Spread-of-Flame Index* of 0 and a *Smoke-Developed Index* not more than 5 if it is used –

- (a) in a Class 2,3, 9a or 9b building – as a finish, surface, lining or attachment to any wall or ceiling in an internal *public corridor*, hallway, or the like, which is a means of egress to –
  - (i) a stairway *required* to be fire-isolated or an external stairway used instead; or
  - (ii) a passageway, or ramp, *required* to be fire-isolated; or
- (b) in a class 9b building which is used as a theatre, public hall, or the like –
  - (i) as a finish, surface, lining, or attachment to any ceiling, wall or floor;
  - (ii) as the covering of fixed seating in the audience seating area; or
  - (iii) in a cinema projection room.

### 5. Acceptable materials

A material complies with clauses 2,3 or 4 if it is –

- (a) plaster, cement render, concrete, terrazzo, ceramic tile or the like; or

---

(b) a fire-protective covering.

continuous contact with a substrate;

## 6. Fire-retardant coatings

When paint or fire-retardant coatings are used in order to make a substrate comply with a *required Spread-of-Flame Index, Smoke-Developed Index or Flammability Index*, this fact must be clearly marked on an easily visible label or labels and permanently fixed to the building element so that the coating will not be scraped off or otherwise made ineffective, without re-coating to preserve the fire-retardant properties. If any coating used will retain the *required* fire-retardant properties for only a limited period, it must be replaced before the expiry of such period so that the *required* properties are not diminished.

(ii) adhesives; or

(iii) damp-proof courses, flashings, caulking, sealing, ground moisture barriers, or the like;

(f) paint, varnish, lacquer or similar finish, other than nitro-cellulose lacquer;

(g) a clear or translucent rooflight of glass fibre reinforced polyester if –

(i) the roof in which it is installed forms part of a building in Type C construction;

(ii) the material is used as part of the roof covering;

(iii) it is not prohibited by any other clause of this Code;

(iv) it is not closer than 1.5m from another rooflight of the same type;

(v) each rooflight is not more than 14m<sup>2</sup> in area; and

(vi) the area of the rooflights is not more than 20% of roof surface; or

## 7. Exempted building parts and materials

The requirements in this Specification for a *Spread-of-Flame Index, Smoke-Developed Index or Flammability Index* do not apply to –

(a) timber-framed windows;

(b) solid timber handrails or skirtings;

(c) timber-faced solid-core or fire doors;

(d) electrical switches, outlets, cover plates or the like;

(e) materials used for –

(h) any other material which does not significantly increase the hazards of fire.

(i) roof covering or membranes, or roof insulating material, applied in

---

---

## FIRE DOORS, SMOKE DOORS, FIRE WINDOWS AND SHUTTERS

### 1. Scope

This Specification sets our requirements for the construction of fire doors, smoke doors, fire *windows* and fire shutters.

### 2. Fire doors

A *required* fire door must comply with NZS 4232, except that –

- (a) it may be fully glazed or incorporate glazing if the tested prototype was similarly glazed;
- (b) the radiation level at a distance of 365 mm from the face of the glazing must not exceed 10 kW/m<sup>2</sup> during the period corresponding to that for *insulation* in the *required* FRL;
- (c) the rise in average temperature on the side of the tested prototype remote from the furnace must not exceed 140°C (except in any glazed part) during the first 30 minutes of the fire test.

### 3. Smoke doors

A *required* smoke door –

- (a) may have one or 2 door leaves;
- (b) must swing –
  - (i) in the direction of egress; or
  - (ii) in both directions if the path of travels to *exits* is in either direction;
- (c) must be *self-closing* and may be fitted with an *automatic* release device; and
- (d) must be constructed of –
  - (i) solid-core timber at least 35mm thick, glazed panels in a timber frame at least 35mm thick, or a metal frame, with a mid-rail or suitable crash bar; or
  - (ii) PVC, or other suitable material;

- (iii) and if necessary, be fitted with smoke seals.

### 4. Fire shutters

A *required* fire shutter must –

- (a) be a shutter that –
  - (i) is identical with a tested prototype that has achieved the *required* FRL;
  - (ii) is installed in the same manner and in an opening that is not larger than the tested prototype; and
  - (iii) did not have a rise in average temperature on the side remote from the furnace of more than 140°C during the first 30 minutes of the test; or
- (b) is a steel shutter complying with NZS 4232 if a metallic fire shutter is not prohibited by NC3.5.

### 5. Fire Windows

A *required* fire window must be –

- (a) identical in construction with a prototype that has achieved the *required* FRL; and
- (b) installed in the same manner and in an opening that is not larger than the tested prototype.

---

## PENETRATION OF WALLS, FLOORS AND CEILINGS BY SERVICES

### 1. Scope

This Specification prescribes materials and methods of installation for services that penetrate walls, floors and ceilings *required* to have a FRL.

### 2. Application

- (a) This Specification applies to installations permitted under this Code as alternatives to systems that have been demonstrated by test to fulfill the requirements of NC3.14.
- (b) This Specification does not apply to installations in ceilings *required* to have a *resistance* to the incipient spread of fire not to the installation of piping that contains or is intended to contain a flammable liquid or gas.

### 3. Metal pipes

- (a) A metal pipe that is not normally filled with liquid must not penetrate a wall, floor or ceiling within 100mm of any *combustible* material unless wrapped or fire stopped to satisfy the requirements of Clause 7, and must be constructed of –
  - (i) copper alloy or stainless steel with a wall thickness of at least 1 mm; or
  - (ii) cast iron or steel (other than stainless steel) with a wall thickness of at least 2 mm.
- (b) An opening for a metal pipe must –
  - (i) be neatly formed, cut or drilled;
  - (ii) be no closer than 200mm to any other service penetration; and
  - (iii) accommodate only one pipe
- (c) A metal pipe must be wrapped but must not be lagged or enclosed in thermal insulation over the length of its penetration of a wall, floor or ceiling unless the lagging or thermal insulation fulfills the requirements of clause 7.

- (d) The gap between a metal pipe and the wall, floor or ceiling it penetrates must be fire-stopped in accordance with clause 7.

### 4. Pipes penetrating sanitary compartments

If a pipe of metal or UPVC penetrates the floor of a *sanitary compartment* in accordance with NC3.15(e) of this Code –

- (a) the opening must be neatly formed and no larger than is necessary to accommodate the pipe or fitting; and
- (b) the gap between pipe and floor must be fire-stopped in accordance with clause 7.

### 5. Wires and cables

If a wire or cable or cluster of wires or cables penetrates a floor, wall or ceiling –

- (a) the opening must be neatly formed, cut or drilled and no closer than 50mm to any other service opening; and
- (b) the opening must be no larger in cross-sectional area than –
  - (i) 2000mm<sup>2</sup> if only a single cable is accommodated and the gap between cable and wall, floor or ceiling is no wider than 15mm; or
  - (ii) 500mm<sup>2</sup> in any other case; and
- (c) the gap between the service and the wall, floor or ceiling must be fire-stopped in accordance with clause 7.

### 6. Electrical switches and outlets

If an electrical switch, outlet, socket or the like is accommodated in an opening or recess in a wall, floor or ceiling –

- (a) the opening or recess must not –
  - (i) be located opposite any point within 300mm horizontal nor 600mm vertically of any opening or recess on the opposite side of the wall; or

- 
- (ii) extend beyond half the thickness of the wall; and
- (b) the gap between the service and the wall, floor or ceiling must be fire-stopped in accordance with clause 7.
- 7. Fire-stopping**
- (a) **Material:** The material used for fire-stopping of service penetrations must be concrete, high temperature mineral fibre, high-temperature ceramic fibre or other material that does not flow at a temperature below 1120°C when tested in accordance with AS 1038.15, and must have –
- (i) demonstrated in a system tested in accordance with NC3.15(a) of this Code that it does not impair the *fire-resisting* performance of the building element in which it is installed; or
- (ii) demonstrated in a test in accordance with (e) that it does not impair the *fire-resisting* performance of the test slab.
- (b) **Installation:** Fire-stopping material must be packed into the gap between the service and wall, floor or ceiling in a manner, and compressed to the same degree, as adopted for testing under 7(a) (i) or (ii).
- (c) **Hollow construction:** If a pipe penetrated a hollow wall (such as a stud wall, a cavity wall or a wall of hollow blockwork) or a hollow floor/ceiling system, the cavity must be so framed and packed with fire-stopping material that the material is –
- (i) installed in accordance with 7(b) to a thickness of 25mm all round the service for the full length of the penetration; and
- (ii) restrained, independently of the service, from moving or parting from
- the surfaces of the service and of the wall, floor or ceiling.
- (d) **Recesses:** If an electrical switch, socket, outlet or the like is accommodated in a recess in a hollow wall or hollow floor/ceiling system –
- (i) the cavity immediately behind the service must be framed and packed with fire-stopping material in accordance with 7(c); or
- (ii) the back and sides of the service must be protected with refractory lining board identical with and to the same thickness as that in which the service is installed.
- (e) **Test:** The test to demonstrate compliance of a fire-stopping material with this Specification must be conducted as follows:
- (i) The test specimen must comprise a concrete slab not less than 1m square and not more than 100mm thick, and appropriately reinforced if necessary for *structural adequacy* during manufacture, transport and testing.
- (ii) The slab must have a hole 50mm in diameter through the centre and the hole must be packed with the fire-stopping material.
- (iii) The slab must be conditioned in accordance with AS 1530.4.
- (iv) Two thermocouples complying with AS 1530.4 must be attached to the upper surface of the packing each about 5mm from its center.
- (v) The slab must be tested on flat generally in accordance with Section 10 of AS1530.4.
-

**PUBLIC BUILDINGS AND GROUP DWELLINGS (CLASS 2 TO 9)**

SECTION **ND**

---

**ACCESS AND EGRESS**

---

**Performance Requirements  
Deemed-To-Satisfy Provisions**

- ND1      Provision for Escape**
  - ND2      Construction of Exits**
  - ND3      Access for People with Disabilities**
-



---

## CONTENTS

### PERFORMANCE REQUIREMENTS

#### DEEMED-TO-SATISFY PROVISIONS

Part	Part
<b>ND1 Provision for Escape</b>	
ND1.1 Application	ND2.4 Separation of rising and descending stair flights
ND1.2 Number of exits required	ND2.5 Open access ramps and balconies
ND1.3 When smoke or fire-isolated exits are required	ND2.6 Smoke lobbies
ND1.4 Exit travel distances	ND2.7 Installations in exits and paths of travel
ND1.5 Distance between alternative exits	ND2.8 Enclosure of space under stairs and ramps
ND1.6 Dimensions of exits	ND2.9 Width of stairways
ND1.7 Travel via smoke or fire-isolated exits	ND2.10 Ramps
ND1.9 External stairways	ND2.11 Fire-isolated passageways
ND1.9 Travel by non-fire-isolated stairways or ramps	ND2.12 Roof as open space
ND1.10 Discharge from exits	ND2.13 Treads and risers
ND1.11 Horizontal exits	ND2.14 Landings
ND1.12 Non-required stairways, ramps or escalators	ND2.15 Thresholds
ND1.13 Number of persons accommodated	ND2.16 Balustrades
ND1.14 Measurement of distances	ND2.17 Handrails
ND1.15 Method of measurements	ND2.18 Fixed platforms, walkways and ladders
<b>ND2 Construction of Exits</b>	ND2.19 Doorways and doors
ND2.1 Application of Part	ND2.20 Swinging doors
ND2.2 Fire-isolated stairways and ramps	ND2.21 Operation of latch
ND2.3 Non-fire-isolated stairways and ramps	ND2.22 Re-entry from fire-isolated exits
	<b>ND3 Access for People with Disabilities</b>
	ND3.1 Application of Part
	ND3.2 Access to building
	ND3.3 Parts of buildings to be accessible
	ND3.4 Concessions

---

---

## PERFORMANCE REQUIREMENTS

### OBJECTIVES

A building must be so designed and constructed that the following objectives are fulfilled:

#### NDP1 Provision for Escape

There must be adequate means of escape in case of fire or other emergency from all parts of the building to a place of safety.

#### NDP2 Construction of Exits

- (a) Stairways, ramps and passageways must be such as to provide safe passage for the users of the building.
- (b) Stairways and ramps must not be uncomfortable or strenuous to use.
- (c) Stairways, ramps, floors and balconies, and any roof to which people normally have access, must have bounding walls, balustrades or other barriers where necessary to protect users from the risk of falling.
- (d) Vehicle ramps and any floor to which vehicles have access must have kerbs or other barriers where necessary to provide protection to pedestrians and to the structure of the building.

#### NDP3 Access for People with Disabilities

Reasonable provision must be made in the design of a building, having regard to its use and location, to facilitate access and circulation by people with disabilities.

### REQUIRED PERFORMANCE

**NDP1.1** The design and construction of buildings must allow all occupants in any or all *fire compartments* to get to-

- (a) any one of more than one *exit* within 2.5 minutes; or
- (b) in the case of buildings with 3 or fewer *storeys* or a basement of less than 50 m<sup>2</sup> *floor area*, to a single *exit* within 1 minute.

**NDP2.1** The design and construction of *exits* must allow for the following optimum conditions during evacuation in any emergency –

- (a) a density in the exit of 2.0 persons/m<sup>2</sup> of *exit floor area*;
- (b) a speed of movement along the slope of the *exit* of 0.5 m/s; and
- (c) an average flow of 1.18 persons per second per metre effective width of *exit*.

In the case of occupancies such as hospitals where evacuation needs the assistance of others and/or of equipment, additional consideration must be given to the design of *exits*.

The *pitch* of any stairway or slope of a ramp must not be unsafe or uncomfortable.

The size of openings in any bounding wall, balustrade or the like must be such as to prevent very young mobile children from going through them and injuring themselves. These must also be designed to discourage young children under 5 years of age from gaining any foothold and climbing over them.

**NDP3.1** People with disabilities must have the facility to gain reasonable access to buildings so that they are not at any material disadvantage when compared with others.

---

## DEEMED-TO-SATISFY PROVISIONS

### PROVISION FOR ESCAPE

#### ND1.1 Application

This Part applies to all buildings except the internal parts of a *sole-occupancy unit* in a Class 2 or 3 building or Class 4 part.

#### ND1.2 Number of exits required

- (a) **All buildings** – Every building must have at least one *required exit*.
- (b) **Class 2 to 8 buildings** – In addition to any *horizontal exit*, not less than 2 *exits* must be provided from each *storey* if the building has a *rise* of 3 or more *storeys* or an *effective height* of more than 10 m
- (c) **Basements** – In addition to any *horizontal exit*, not less than 2 *exits* must be provided from any *storey* if egress from that *storey* involves an upward vertical climb within the building of more than 1.5m, unless-
- (i) in addition to a single *exit* other than a *horizontal exit*, one or more openable or easily breakable *windows* or other openings are available in which case the top of the sill must be no higher than 1.5 m from the floor level of the room. In addition the *windows* or openings must have one clear dimension of at least 600 mm and a minimum opening of 0.6 m<sup>2</sup>. The *windows* or openings must be clear of any surrounding ground by at least 1 m horizontally and the vertical drop from the sill to the ground outside, no more than 2 m; or
- (ii) the area of the *storey* is not more than 50 m<sup>2</sup> as well as the distance of travel from any point on the floor to a single *exit*, not more than 20 m.
- (d) **Class 9 buildings** – In addition to any *horizontal exit*, and subject to (e) and (f) not less than 2 *exits* must be provided from –
- (i) each *storey* if the building has a *rise* of 3 or more *storeys* or an *effective height* of more than 10 m;
- (ii) any *storey* which includes a *ward area* in a Class 9a building;

(iii) each *storey* in a Class 9b building used as an *early childhood centre*; and

(iv) any *storey* or *mezzanine* that accommodates more than 100 persons, calculated under ND1.13.

(e) **Exits from divided wards:** In a Class 9a building, at least one *exit* must be provided from every portion of a *storey* which has been divided in accordance with NC2.5.

(f) **Exits in open spectator stands;** In an *open spectator stand* containing more than one tier of seating, every tier must have not less than 2 stairways or ramps, each forming part of the path of travel to not less than 2 *exits*.

#### ND1.3 When smoke or fire-isolated exits are required

Every *required exit* other than an external stairway or open ramp must be –

(a) smoke isolated to the relevant requirements of ND2.6(b) and (c) if it connects 3 or more consecutive *storeys*; and

(b) fire isolated if it connects 5 or more consecutive *storeys*.

**Exception:** These requirements do not apply to *exits* that form part of an *open spectator stand*.

#### ND1.4 Exit travel distances

##### (a) Class 2 and 3 buildings and class 4 parts:

(i) The entrance doorway of any *sole-occupancy unit* must be not more than 6 m from an *exit* or from a point at which travel in different directions to 2 *exits* is available. Further the route of travel within the unit from any point other than from a kitchen or cooking area, to the doorway must not traverse through a kitchen or cooking area; and

(ii) no point on the floor of a room which is not in a *sole-occupancy unit* must be more than 20 m from an *exit* or from a point at which travel in different directions to 2

*exits* is available, in which case the maximum distance to one of those *exits* must not exceed 40 m from the starting point.

complying with Specification NC3.4 and which do not extend higher than 800 mm from the underside of an imperforate roof covering, floor or ceiling above it; and

(b) **Class 5 to 9 buildings:**

Subject to (c), (d) and (e):

(i) No point on a floor must be more than 20 m from an *exit*, or a point from which travel in different directions to 2 *exits* is available, in which case the maximum distance to one of those *exits* must not exceed 40 m from the starting point.

(ii) In a Class 5 or 6 building, the distance to a single *exit* serving at the level of access to a road or *open space* may be increased to 30 m.

(c) **Class 9a buildings:** In a *ward area* in a Class 9a building –

(i) no point on the floor must be more than 12 m from a point from which travel in different directions to 2 of the *required exits* is available; and

(ii) the maximum distance to one of those *exits* must not be more than 30 m from the starting point.

(d) **Open spectator stands:** The distance of travel to an *exit* in a Class 9b building used as an *open spectator stand* must be not more than 60 m.

(e) **Assembly buildings:** In a Class 9b building other than a *school* or *early childhood centre*, the distance to one of the *exits* may be 60 m if-

(i) the path of travel from the room concerned to that *exit* is through another area which is a corridor, hallway, lobby, ramp or other circulation space;

(ii) the room is smoke-separated from the circulation space by construction such that-

- any wall be *non-combustible* and extend to the underside of the floor above or of the roof covering;
- only have doorways which are fitted with smoke doors

(iii) the maximum distance of travel does not exceed 40 m within the room and 20 m from the doorway to the room through the circulation space to the *exit*.

**ND1.5 Distance between alternative exits**

*Exits* that are *required* as alternative means of egress must be –

(a) distributed as uniformly as practicable within or around the *storey* served:

(b) not less than 9 m apart; and

(c) not more than –

(i) 45 m apart in a Class 2 or 3 building or a *storey* containing a *ward area* in a Class 9 a building; or

(ii) 60 m apart in all other cases.

**ND1.6 Dimensions of exits**

In a *required exit* or path of travel to an *exit* –

(a) the unobstructed height throughout must be not less than 2 m;

(b) if the *storey* or *mezzanine* pertains to a Class 2 or 3 buildings or accommodates not more than 100 persons, the unobstructed width except for doorways must be-

(i) not less than 1 m ; or

(ii) 2 m in a passageway from a *ward area*:

(c) if the *storey* or *mezzanine* accommodates more than 100 persons and not more than 200 persons the aggregate width, except for doorways, must be not less than-

(i) 1 m plus 250 mm for each 25 persons (or part) in excess of 100; or

(ii) 2 m in a passageway from a *ward area* in class 9a buildings;

(d) if the *storey* or *mezzanine* accommodates more than 200 persons, the aggregate width, except for doorways, must be increased to-

- (i) 2 m plus 500 mm for every 60 persons (or part) in excess of 200 persons if egress involves a change in floor level by a stairway or ramp with a gradient more than 1:12; or
- (ii) in any other case, 2 m plus 500 mm for every 75 persons (or part) in excess of 200;

(e) in an *open spectator stand* which accommodates more than 2000 persons the width except for doorways must be increased to 17 m plus a width (in meters) equal to the number in excess of 2000 divided by 600;

(f) the clear openings of a doorway must be not less than-

- (i) in *ward areas* – 1.6 m wide or 1.25 m if it is a *horizontal exit*;
- (ii) in areas used by students in a *school*-870 mm wide;
- (iii) the width of *exit required* by (b), (c), (d) or (e), minus 250 mm, or
- (iv) in any other case except where it opens to a *sanitary compartment* or bathroom – 760 mm wide; and

(g) the *required* width of *exits* must not diminish in the direction of travel to a road or *open space*.

#### **ND1.7 Travel via smoke or fire-isolated exits**

(a) A doorway from a room must not open directly into a stairway, passageway or ramp that is *required* to be smoke or fire-isolated unless it is from-

- (i) a public lobby, *public corridor*, hallway, or the like;
- (ii) a *sole-occupancy unit* occupying all of a *storey*; or
- (iii) a *sanitary compartment*, airlock or the like.

(b) Each stairway or ramp that is *required* to be smoke or fire isolated must provide independent egress from the *storey* served and discharge-

(i) directly, or by way of a *fire-isolated passageway*, to a road or *open space*; or

(ii) into a *storey* or space within the confines of the building that is enclosed for not more than 1/3 of its perimeter and used only for pedestrian movement, car parking, or the like, to a point where an unimpeded path of travel not further than 20 m is available to a road or *open space*.

(c) If more than 2 access doors, other than from a *sanitary compartment* or the like, open to a *fire-isolated exit* in the same *storey* –

- (i) a smoke lobby in accordance with ND2.6 must be provided; or
- (ii) the *exit* must be pressurised in accordance with NE2.7.

(d) A ramp must be provided at any change in level less than 600 mm in a *fire-isolated passageway* in a Class 9 building.

#### **ND1.8 External stairways**

An external stairway may serve as a *required exit* instead of a smoke isolated or *fire-isolated stairway* in a building with an *effective height* of not more than 25 m if the stairway (including any connecting bridges) is of *non-combustible* construction throughout, and –

(a) if any part of the stairway is exposed to, and less than 6 m from, a *window*, doorway or the like in an *external wall*, the stairway must be fully shielded in the affected area from such *window* or doorway by *non-combustible* construction with a FRL of not less than 60/60/60;

(b) if any part of the stairway is exposed to, and less than 6 m but more than 3 m from, a *window*, doorway or the like in an *external wall* of any building, the *window* doorway or the like must be protected in accordance with NC3.4.

#### **ND1.9 Travel by non-fire-isolated stairways or ramps**

(a) A *non-fire-isolated stairway* serving as a *required exit* must provide a continuous means of travel by its own flights of stairs and landings from every *storey* served to the level at which egress to a road or *open space* is provided.

(b) In a Class 2,3 or 4 building, the distance between the doorway of a room or *sole-occupancy unit* and the point of egress to a road or *open space* by way of any *required* stairway or ramp that is not fire-isolated must not exceed –

(i) 30 m in a building of Type C construction; or

(ii) 60 m in all other cases.

(c) In a Class 5 to 9 building, the distance from any point on a floor and a point of egress to a road or *open space* by way of a *required non-fire-isolated stairway* or ramp must not exceed 80 m.

(d) In a Class 2,3 or 9a building, a *required non-fire-isolated stairway* or ramp must discharge at a point not more than –

(i) 15 m from a doorway providing egress to a road or *open space* or from a *fire-isolated passageway* leading to a road or *open space*; or

(ii) 30 m from one of 2 such doorways or passageways if travel to each of them from the stairway or ramp is in opposite or approximately opposite directions.

(e) In a Class 5 to 8 or 9a building, a *required non-fire-isolated stairway* or ramp must discharge at a point not more than –

(i) 20 m from a doorway providing egress to a road or *open space* or from a *fire-isolated passageway* leading to a road or *open space*; or

(ii) 40 m from one of 2 such doorways or passageways if travel to each of them from the stairway or ramp is in opposite or approximately opposite directions.

(f) If 2 or more *exits* are *required* and are provided by means of internal *non-fire-isolated stairways* or *non fire-isolated ramps*, each *exit* must –

(i) provide separate egress to a road or *open space*; and

(ii) be suitably smoke-separated from each other at the level of discharge.

#### ND1.10 Discharge from exits

(a) An *exit* must not be blocked at the point of discharge and where necessary, suitable barriers must be provided to prevent vehicles from blocking the *exit*, or access to it.

(b) If a *required exit* leads to an *open space*, the path of travel to the road must have an unobstructed width throughout of not less than –

(i) the minimum width of the *required exit*; or

(ii) 1 m;

whichever is the greater

(c) If an *exit* discharges to *open space* that is at a level different from the public road to which it is connected, the path of travel to the road must be by-

(i) a ramp or other incline having a grade of not more than 1:8 at any part, or 1:14 if *required* by Part ND3; or

(ii) a stairway complying with this Code, except if the *exit* is from a Class 9a building.

(d) The discharge point of alternative *exits* must be located as far apart as practicable.

(e) In a Class 9b building which is an *open spectator stand* that accommodates more than 500 persons a *required* stairway or *required* ramp must not discharge to the ground in front of the stand.

(f) In a Class 9b building containing an auditorium which accommodates more than 500 persons, not more than 2/3 of the *required* width of *exits* must be located in the main entrance foyer.

#### ND1.11 Horizontal exits

*Horizontal exits* must-

(a) not be counted as a *required* exits, when-

(i) between *sole-occupancy units*; or

(ii) in a Class 9b building used as an *early childhood centre*, primary or secondary school;

(b) not comprise more than 50% of the number of *required* exits from any part of a storey which has been divided by a *fire wall*; and

(c) have a clear area on each side of the *fire wall* to accommodate the total number of persons (calculated under ND1.13) from both parts of the storey, of not less than –

- 
- (i) 2.5 m<sup>2</sup> per patient in a Class 9a building; and
  - (ii) 0.5 m<sup>2</sup> per person in any other case.

**ND1.12 Non-required stairways, ramps or escalators**

Escalators, moving walkways or non-*required non-fire isolated stairways* or pedestrian ramps –

- (a) must not be used in a *ward* area in a Class 9a building;
- (b) may connect any number of *storeys* if they are –
  - (i) in an *open spectator stand* or indoor sports stadium;
  - (ii) in a *carpark* or an *atrium*; or
  - (iii) outside a building;
- (c) must not connect, directly or indirectly, more than 2 consecutive *storeys* at any level in a Class 5,6,7,8 or 9 building; and
- (d) in any other case, must not connect more than 2 consecutive *storeys*, provided that one of those *storeys* is situated at a level at

which there is direct egress to a road or *open space*.

**ND1.13 Number of persons accommodated**

The number of persons accommodated in a *storey*, room or *mezzanine floor* must be determined with consideration to the purpose for which it is used and the layout of the *floor area* by –

Calculating the sum of the numbers obtained by dividing the *floor area* of each part of the *storey* by the number of square metres per person listed in Table ND1.13 according to the use of the part, excluding spaces set aside for –

- (i) Lifts, stairs, ramps and escalators, corridors, hallways, lobbies, and the like;
  - (ii) Service ducts and the like, *sanitary compartments* or other ancillary uses;
- (a) reference to the seating capacity in an assembly building or room; or
  - (b) any other suitable means of assessing its capacity.

**TABLE ND 1.13  
AREA PER PERSON ACCORDING TO USE**

TYPE OF USE	m2 per person
Art gallery, exhibition area, museum	4
Bar, café, church, dining room	1
Board room	2
Boarding house	15
Computer room for main frame and mini computers	25
Court room – judicial area	10
- public seating	1
Dance floor	0.5
Dormitory	8
Early childhood centre	4
Factory - (a) machine shop, fitting shop, or like place for cutting, grading, finishing or fitting of metals or glass, except in the fabrication of structural steelwork or manufacture of vehicles or bulky products	5
(c) areas used for fabrication and processing other than those in (a)	50
(d) a space in which the layout and natural use of fixed plant or equipment determine the number of persons which will occupy the space during working hours	Area per person determined by the use of the plant or equipment
Garage public	30
Gymnasium	3
Hospital ward area	10
Hostel, hotel, motel, guest house	15
Indoor sports stadium arena	10
Kiosk	1
Kitchen, laundry (other than domestic) and laboratory	10
Library - reading space	2
- storage space	30
Office, including one for typewriting or document Copying or with desk-top computers	10
Plant Room for - ventilation, electrical or other Service units	30
- boilers or power plant	50
Reading Room	2
Restaurant	1
School - common staff room	2
- individual staff room	10
- general classroom	2
- only as for others	
- multi-purpose hall	1
- trade and practical area: primary	4
secondary	As for workshop
Shop - space for sale of goods	
(a) at a level entered direct from the open air or any lower level	3
(b) all other levels	5



**TABLE ND 1.13 Continued**  
**AREA PER PERSON ACCORDING TO USE**

Showroom - display	5
Skating rink, based on rink area	1.5
Spectator stand, audience viewing area	450 mm/person
- bench seating	number of sales
- fixed seating	1
- seating not fixed	0.3
- standing viewing area	30
Storage space	30
Swimming pool, based on pool area	1.5
Switch room, transformer room	30
Telephone exchange - private	30
Theatre dressing room	4
Transport terminal	2
Workshop - for maintenance staff	30 (in the whole area)
- for manufacturing processes	As for factory

**ND1.14 Measurement of distances**

The nearest part of an *exit* means in the case of –

1. A *fire-isolated stairway, fire-isolated passageway, fire-isolated ramp*, the nearest part of the doorway providing access to them.

- (a) A *non-fire-isolated stairway*, the nearest part of the nearest riser.
- (b) A *non-fire-isolated ramp*, the nearest part of the junction of the floor of the ramp and the floor of the *storey*.
- (c) A doorway opening to a road or *open space*, the nearest part of that doorway.
- (d) A *horizontal exit*, the nearest part of the doorway.

**ND1.15 Method of measurement**

The following rules apply:

- (a) In the case of a room that is not a *sole-occupancy unit* in a class 2 or 3 building or class 4 part of a building, a distance includes the straight-line measurement from any point on the floor of the room to the nearest part of a doorway leading from it, together with the distance from that part of the doorway to the single *required exit* or point from which travel in different directions to 2 *required exits* is available.

(b) Subject to (d) and (f), the distance from the doorway of a room or *sole-occupancy unit* in a Class 2, 3 or 4 building is measured in a straight line to the nearest part of the *required* single *exit* or point from which travel in different direction to 2 *required exits* is available.

(c) Subject to (d) and (f), the distance between *exits* is measured in a straight line between the nearest parts of those *exits*.

(d) Only the shortest distance is taken along a corridor, hallway, external balcony or other path of travel that curves or changes direction.

(e) If more than one corridor, hallway, or other similarly defined internal path of travel connects *required exits*, the measurement is along the path of travel through the point at which travel in different directions to those *exits* is available.

(f) If a wall (including a demountable *internal wall*) that does not bound –

- (i) a room; or
- (ii) a corridor, hallway or the like,

causes a change of direction in proceeding to a *required exits*, the distance is measured along the path of travel past the wall.

- 
- (g) If permanent fixed seating is provided, the distance is measured along the path of travel between the rows of seats.
-

---

## CONSTRUCTION OF EXITS

### ND2.1 Application of Part

Except for ND2.13 and ND2.16, this Part does not apply to the internal parts of a *sole-occupancy unit* in a Class 2 or Class 3 building or a Class 4 part.

### ND2.2 Fire-isolated stairways and ramps

A stairway or ramp (including any landings) that is *required* to be within a *fire-resisting shaft* must be constructed –

- (a) of *non-combustible* materials; and
- (b) so that if there is local failure, it will not cause structural damage to, or impair the fire-resistance of the *shaft*.

### ND2.3 Non-fire-isolated stairways and ramps

In a building having a *rise* of more than 2 *storeys*, *required stairs* and ramps (including landings and any supporting *structural members*) which are not *required* to be within a *fire-resisting shaft*, must be constructed according to ND2.2, or only of-

- (a) reinforce or prestressed concrete;
- (b) steel in no part less than 6mm thick; or
- (c) timber that-
  - (i) has a finished thickness of not less than 40 mm;
  - (ii) has an average density of not less than 800 kg/m<sup>3</sup> at a moisture content of 12%; and
  - (iii) has not been joined by means of glue unless it has been laminated and glued with resorcinol formaldehyde or resorcinol phenol formaldehyde glue.

### ND2.4 Separation of rising and descending stair flights

If a stairway serving as an *exit* is *required* to be fire-isolated –

- (a) there must be no direct connection between a flight of stairs rising from a *storey* below the lowest level of access to a road or *open space*, and a flight of stairs descending from a *storey* above that level; and
- (b) any construction that separates or is common to the rising and descending flights of stairs must be *non-combustible* and have a FRL of not less than 60/60/60.

### ND2.5 Open access ramps and balconies

A *required* open access ramp or balcony must –

- (a) have ventilation openings to the outside air which –
  - (i) have a total unobstructed area not less than the *floor area* of the ramp or balcony; and
  - (ii) are evenly distributed along the open sides of the ramp or balcony; and
- (b) not be enclosed on its open sides above a height of 1 m except by an open grille or the like having a free air space of not less than 75% of its area.

### ND2.6 Smoke lobbies

A smoke lobby *required* by ND1.7 must –

- (a) have a *floor area* not less than 6 m<sup>2</sup>;
- (b) be separated from the occupied areas in the *storey* by walls which are impervious to smoke, and –
  - (i) have a FRL of not less than 30/30/- (which may be plasterboard, face brickwork, glass blocks or glazing);
  - (ii) extend from floor to floor, or to the underside of a ceiling with a *resistance* to the *incident spread of fire* of 60 minutes which covers the lobby;
  - (iii) construction joints between the top of the walls and the floor, roof or ceiling must be smoke sealed with intumescent putty or other suitable material;
- (c) at any opening from the occupied areas, have smoke doors to Specification NC3.4, which are *self-closing* or held open by a fail-safe *automatic* magnetic release device; and
- (d) be pressurised to NE2.7 as part of the *exit* if the *exit* is *required* to be pressurised.

---

## ND2.7 Installations in exits and paths of travel

- (a) Access to service *shafts* and services other than to fire-fighting or detection equipment as permitted in Section NE, must not be provided from a *fire-isolated stairway*, passageway or ramp.
- (b) An opening to any chute or duct conveying hot products of combustion must not be located in any part of a *required exit* or any corridor, hallway, lobby or the like leading to a *required exit*.
- (c) Gas or other fuel services must not be installed in a *required exit*.
- (d) Services or equipment must not be installed in a *required exit* or in any corridor, hallway, lobby or the like leading to a *required exit* if it comprises –
  - (i) electricity meters, distribution boards or ducts;
  - (ii) central telecommunications distribution boards or equipment; or
  - (iii) electrical motors or other motors serving equipment in the building;

unless it is enclosed by *non-combustible* construction or a *fire-protective covering*.

## ND2.8 Enclosure of space under fire-isolated stairs and ramps

- (a) **Fire-isolated stairways and ramps** – If the space below a *required fire-isolated stairway* or ramp is within the fire-isolated *shaft*, it must not be enclosed to form a cupboard or similar enclosed space.
- (b) **Non-fire-isolated stairways and ramps** – The space below a *required non-fire-isolated stairway* (including an external stairway) or ramp must not be enclosed to form a cupboard or other enclosed space unless –
  - (i) the enclosing walls and ceilings have a FRL of not less than 60/60/60; and
  - (ii) any access doorway to the enclosed space is fitted with a self-closing - /60/30 fire door.

## ND2.9 Width of stairways

- (a) The *required* width of a stairway must –

- (i) be measured clear of all obstructions such as handrails, projecting parts of balustrades, columns, beams, and the like; and
- (ii) extend without interruption, except for ceiling cornices, to a height not less than 2 m vertically above a line along the nosings of the treads or the floor of the landing.

- (b) A *required* stairway that exceeds 2 m in width is counted as having a width of only 2 m unless it is divided by a balustrade or handrail continuous between landings and each division is less than 2 m wide.

## ND2.10 Ramps

### ND2.10.1 Pedestrian ramps

- (a) A *fire-isolated* ramp may be substituted for a *fire-isolated stairway* if the construction enclosing the ramp and the width and ceiling height comply with the requirements for a *fire-isolated stairway*.
- (b) a ramp serving as a *required exit* must have a gradient of not more than –
  - (i) 1:12 in areas used by patients in a Class 9a building; or
  - (ii) 1:14 if *required* by Part ND3;
  - (iii) 1:10 if subject to wetting; or
  - (iv) 1:8 in any other case.
- (c) The floor surface of a ramp must have a non-slip finish.

### ND2.10.2 Service ramps

Service ramps must not be steeper than 1:3. Where they are steeper than 1:8 cleats must be provided at the spacing shown in Table ND2.10.1. Two examples are shown in figure ND2.10.2.

TABLE ND 2.10.2 SPACING OF CLEATS FOR SERVICE RAMPS		
Ramp slope not more than	CLEAT SPACING (mm)	
	Goods carried	No goods carried
1:6	360	460
1:5	330	430
1:4	300	400
1:3	280	380

### ND2.11 Fire-isolated passageways

A *fire-isolated passageway* must be enclosed by walls, floors, and ceilings of *non-combustibles* construction with a FRL of –

- (a) not less than that *required* for the stairway or ramp *shaft* if the passageway discharges from a *fire-isolated stairway* or ramp; or
- (b) in any other case – not less than 60/60/60.

### ND2.12 Roof as open space

If an *exit* discharges to a roof of a building, the roof must –

- (a) have a FRL of not less than 120/120/120; and
- (b) not have any rooflights or other openings within 3 m of the path of travel of persons using the *exit* to reach a road or *open space*.

## ND2.13 Treads and risers

### ND2.13.1 Straight flights

- (a) A stairway must be suitable to provide safe passage in relation to the nature, volume and frequency of likely usage.
- (b) A stairway in any building (including a *sole-occupancy unit* in a Class 2 or 3 building or Class 4 part) satisfies (a) if it has –
  - (i) not more than 18 or less than 2 risers in each flight, except in a Class 9 building subject to ND1.7 (d);
  - (ii) subject to (ix), going and riser dimensions in accordance with Figure ND2.13.1 and Table ND2.13.1 that are constant throughout each flight;
  - (iii) risers which do not have any openings that would allow a 100 mm sphere to pass through between the treads;
  - (iv) treads which have a non-slip finish or a suitable non-skid strip near the edge of the nosings;
  - (v) treads of solid construction (not mesh or other perforated material) if the stairway is more than 10 m high or connects more than 3 *storeys*;
  - (vi) in a Class 9 building – not more than 36 successive risers and landings without a change in direction of at least 30°; and
  - (vii) a cross fall of between 1:100 and 1:50 where the stairway is subject to wetting;
  - (viii) treads not exceed the goings by more than 30 mm; and
  - (ix) in a *sole occupancy unit* in a Class 2 building or class 4 part, or where it is not part of a *required exit* and to which there is no normal access to the public, going and riser dimensions to Table DD1.1

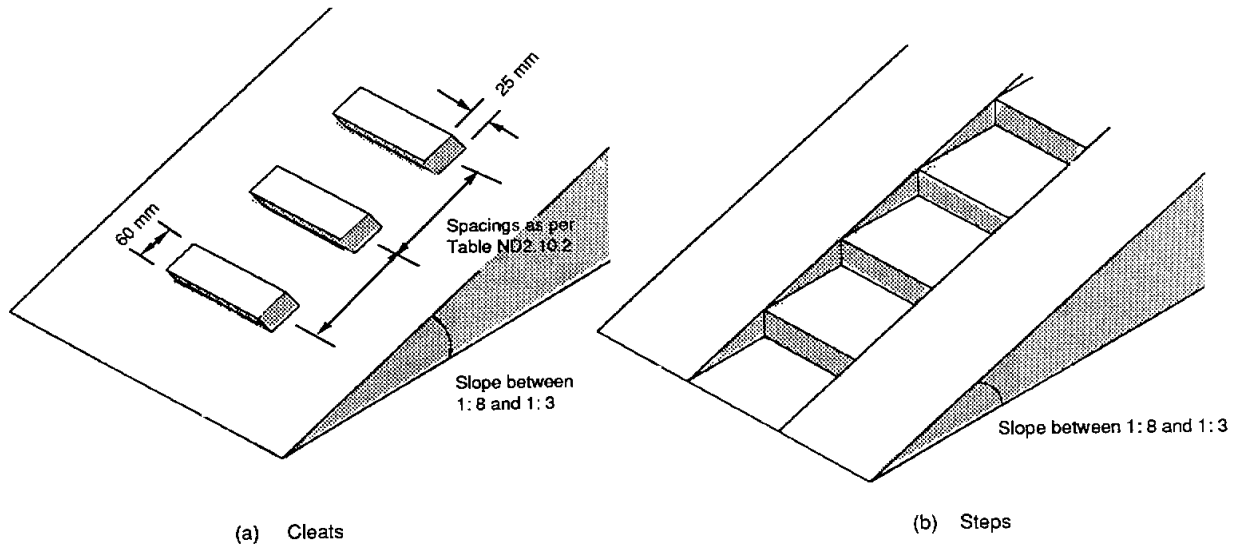

FIGURE ND2.10.2 EXAMPLES OF SERVICE RAMPS WITH CLEATS

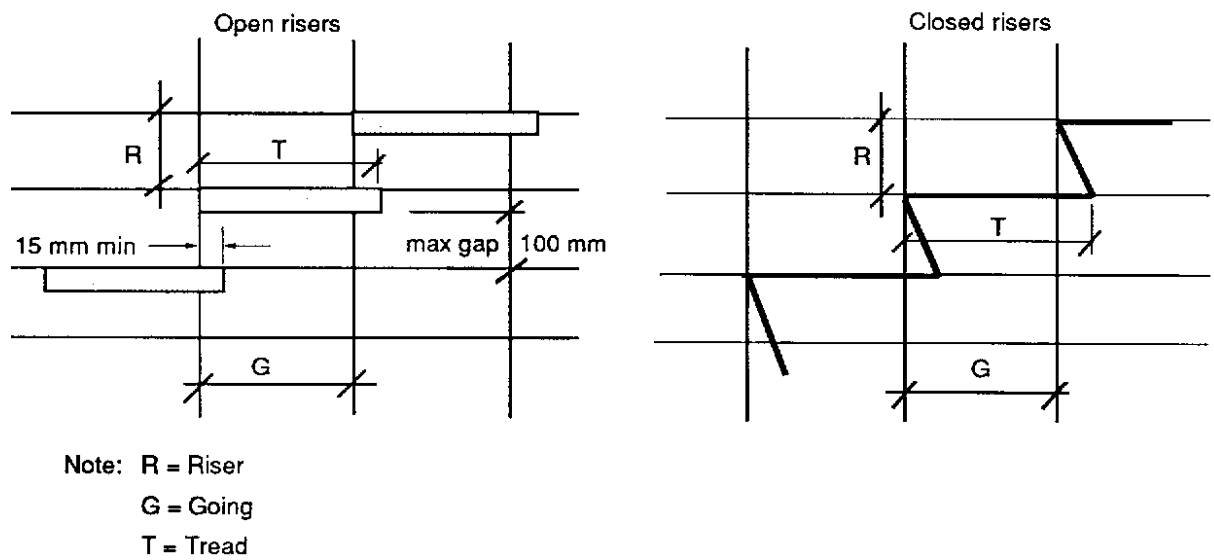

FIGURE ND2.13.1 MEASUREMENT OF RISER GOING AND TREAD

**TABLE ND 2.13.1  
RISER DIMENSIONS (mm) TO MATCH GOING**

Pitch	GOING (mm)								
	250	260	270	280	290	300	310	320	330
37°	188								
36°	182	188							
35°	175	182	189						
34°	168	175	182	188					
33°	162	169	175	181	188				
32°	156	162	168	174	181	187			
31°	150	156	162	167	174	180	186		
30°		150	156	161	167	173	179	185	
29°			150	155	161	167	173	179	183
28°				150	155	160	165	170	175
27°					148	153	158	163	168
26°						146	151	156	161
25°								149	154
24°									147

**Notes:**

1. Actual riser dimension may be selected to suit the inter landing height. However the value of the riser dimension must not be outside the maximum or minimum dimensions shown for each value of going.
2. The dimensions shown within the outlined box are preferred because they are less strenuous for individuals on crutches or with minor disabilities.

---

**ND2.13.2 Curved stairs**

Curved stairs must comply with the relevant requirements of ND2.13.1 as well as the following:

- (a) For the purposes of satisfying Table ND2.13.1 or Table DD1.1 in the case of stairs in ND2.13.1 (ix), the going must be measured:
  - (i) along half way across the width of the stair where the clear width is less than 900 mm; and
  - (ii) 300 mm from each side of the stair where the clear width is 900 mm or more.
- (b) All steps must have the same uniform taper.
- (c) The going at the narrow end of the steps must be not less than 75 mm.
- (d) Winders are not permitted.

**ND2.14 Landings**

In a stairway –

- (a) landings having a maximum slope of 1:50 may be used in any building to limit the number of risers in each flight and each landing must –
  - (i) be not less than 750 mm long measured 500 mm from the inside edge of the landing; and
  - (ii) have a non-slip finish throughout or a suitable non-skid strip near the edge of the landing where it leads to a flight of stairs below; and
- (b) in a Class 9a building –
  - (i) the area of any landing must be sufficient to move a stretcher, 2 m long and 600 mm wide, at an incline not more than the slope of the stairs, with at least one end of the stretcher on the landing while changing direction between flights; or
  - (ii) the stair must have a change of direction of 180°, and the landing a clear width of not less than 1.6m and a clear length of not less than 2.7 m.

**ND2.15 Thresholds**

The threshold of a doorway must not incorporate a step or ramp at any point closer to the doorway than the width of the door leaf unless –

- (a) in patient-care areas in a Class 9a building, the door sill is not more than 25 mm above the finished surface of the ground, balcony or the like to which the doorway opens;
- (b) in other cases-
  - (i) the doorway opens to a road, *open space* or external balcony; and
  - (ii) the door sill is not more than 190 mm above the finished surface of the ground, balcony, or the like, to which the doorway opens.

**ND2.16 Balustrades**

- (a) In a Class 2,3,4,5,6 or 9 building and a Class 7 building used as a *public carpark*, a continuous balustrade must be provided along the side of any stairway or ramp, or any corridor, hallway, balcony, bridge or the like, if –
  - (i) it is not bounded by a wall; and
  - (ii) the change in level is more than 1 m, except at the perimeter of a stage, rigging loft, loading dock an area accessible only to maintenance staff, or the like.
- (b) A balustrade *required* by (a) must prevent, as far as practicable –
  - (i) children climbing over or through it;
  - (ii) persons accidentally falling from the floor; and
  - (iii) objects which might strike a person at a lower level accidentally falling from the floor surface.
- (c) In low risk areas such as *fire-isolated stairways*, *fire-isolated ramps* or external stairways that are provided instead of *fire-isolated stairways*, other areas used exclusively for emergency purposes and other stairways and ramps (including access bridges and landings), where the change in level is not more than 2 m a balustrade satisfies (b) if –
  - (i) the balustrade has a height of not less than 865 mm above the nosings of the stair treads and the floor of the landing, access bridge or the like; and



- (ii) the space between balusters or the width of any opening in the balustrade (including any openable *window* or panel) is not more than 100 mm except where the space between rails or the height of any opening is not more than 100 mm.
- (d) At balconies a balustrade satisfies (b) if
- (i) it has a height of not less than 930 mm above the balcony floor;
  - (ii) the space between balusters or the width of any opening in the balustrade is not more than 100 mm except where the space between rails or the height of the opening is not more than 100 mm;
  - (iii) all parts of the balustrade more than 150 mm and less than 760 mm from the floor or nosings are vertical or otherwise do not provide a toe-hold; and
- (e) In stairways and ramps (including access bridges and landings) where the change in level is more than 2 m, a balustrade satisfies (b) if –
- (i) it has a height of not less than 865 mm above the nosings of the stair treads and the floor of the landing, balcony, corridor, hallway, access bridge or the like;
  - (ii) the space between balusters or the width of any opening in the balustrade (including any openable window or panel) is not more than 100 mm except where the space between rails or the height of the opening is not more than 100 mm; and
  - (iii) all parts of the balustrade more than 150 mm and less than 760 mm from the floor or nosings are vertical or other wise do not provide a toe-hold.
- (f) A balustrade or other barrier in front of fixed seating in a *mezzanine floor* or balcony in a Class 9b building satisfies (b) if it complies with (d), or –
- (i) it is not less than 700 mm in height above the *mezzanine floor* or balcony floor and a horizontal projection extends not less than 1 m outwards from the top of the balustrade; and

- (ii) the space between balusters or the width of any opening in the balustrade is not more than 100 mm except where the space between rails or the height of the opening is not more than 100 mm.

#### ND2.17 Handrails

- (a) Except in a Class 7 or 8 building other than a *public carpark*, suitable handrails must be provided where necessary to assist and provide stability to persons using a ramp or stairway.
- (b) Handrails satisfy (a) if they are –
- (i) located along at least one side of the ramp or flight of stairs;
  - (ii) located along each side if it is a Class 9b building that is used as an *early childhood centre* or as a *primary school*, or if the total width of the stairway or ramp is 2m or more;
  - (iii) not more than 2 m apart in the case of intermediate handrails;
  - (iv) fixed at a height of not less than 700 mm above the nosings of stair treads in a Class 9b building that is used as a *primary school*;
  - (v) in any other case fixed at a height of not less than 865 mm above the nosing of stair treads and the floor surface of the ramp, landing, or the like; and
  - (vi) continuous between stair flight landings and have no obstruction on or above them that will tend to break a hand-hold.
- (c) Handrails in a Class 9a building must be provided along at least one side of every passageway or corridor used by patients, and must be –
- (i) fixed not less than 50 mm clear of the wall; and
  - (ii) where practicable, continuous for their full length.

#### ND2.18 Fixed platforms, walkways and ladders

Fixed platforms, walkways, non-*required* stairways, handrails, balustrades and ladders must comply with AS 1657 in –

- (a) a Class 7 or Class 8 building, or part of a building; and
- (b) lift motor rooms, plant rooms, and the like.

---

### ND2.19 Doorways and doors

A doorway serving as a *required exit*, forming part of a *required exit*, or in a patient-care area of a Class 9a building-

- (a) must not be fitted with a revolving door;
- (b) must not be fitted with a roller shutter or tilt-up door unless –
  - (i) it serves a Class 6,7 or 8 building or part with a *floor area* not more than 200 m<sup>2</sup>;
  - (ii) the doorway is the only *required exit* from the building or part; and
  - (iii) it is held in the open position while the building or part is lawfully occupied;
- (c) must not be fitted with a sliding door unless-
  - (i) it leads directly to a road or *open space*; and
  - (ii) the door can be opened manually under a force of not more than 10 kg; and
- (d) if fitted with a door which is power-operated-
  - (i) it must be able to be opened by hand under a force of not more than 10 kg if there is a malfunction or failure of the power source; or
  - (ii) it must open *automatically* if there is a power failure or on the activation of a fire or smoke alarm anywhere in the part served by the door.

### ND2.20 Swinging doors

A swinging door in a *required exit* or forming part of a *required exit* –

- (a) must not encroach –
  - (i) at any part of its swing by more than 500 mm on the *required* width of a *required* stairway, passageway or ramp, including the landings; and
  - (ii) when fully open, by more than 100 mm on the *required* width of the *required exit*, and

the measurement of encroachment in each case is to include door handles or other furniture or attachments to the door;
- (b) must swing in the direction of egress unless-

- (i) it serves a building or part with a *floor area* not more than 200 m<sup>2</sup>, it is the only *required exit* from the building or part and it is fitted with a device for holding it in the open position; or
- (ii) it serves a *sanitary compartment* or airlock (in which case it may swing in either direction); and
- (c) must not otherwise impede the path or direction of egress.

### ND2.21 Operation of latch

A door in a *required exit*, forming part of a *required exit* or in the path of travel to a *required exit* must be readily openable without a key from the side that faces a person seeking egress, by a single-hand downward or horizontal pushing action on a single device which is located between 900 mm and 1200 mm from the floor, unless-

- (a) it serves a vault, strong room, *sanitary compartment*, or the like; or
- (b) it serves only, or is within –
  - (i) a *sole-occupancy* unit in a Class 2 building or a Class 4 part;
  - (ii) a *sole-occupancy* unit in a Class 5,6,7 or 8 building with a *floor area* not more than 200 m<sup>2</sup>; or
  - (iii) a space which is otherwise inaccessible to persons at all times when the door is locked; or
- (c) it serves a bank or other occupancy where special arrangements for security are necessary and it can be immediately unlocked-
  - (i) by operating a fail-safe control switch, not contained within a protective enclosure, to actuate a device to unlock the door; or
  - (ii) by hand by a person or persons, specifically nominated by the owner, properly instructed as to the duties and responsibilities involved and available at all times when the building is lawfully occupied so that persons in the building or part may immediately escape if there is a fire or other emergency, or
- (d) it is fitted with a fail-safe device which *automatically* unlocks the door upon the activation of any *sprinkler system* or smoke or thermal detector system installed throughout the building.

---

**ND2.22 Re-entry from fire-isolated exits**

Doors must not be locked from inside a *fire-isolated stairway, fire-isolated ramp or fire-isolated passageway* enclosure to prevent re-entry to the storey or room it serves in-

(a) a Class 9a building; or

(b) a building more than 25 m in *effective height* unless all the doors are *automatically* unlocked by a fail-safe device upon the activation of a fire alarm, and at least at every fourth storey the doors are not able to be locked and a sign is fixed on it stating that re-entry is available.

## ACCESS FOR PEOPLE WITH DISABILITIES

### ND3.1 Application of Part

This Part applies to all Class 3,5,6,7,8 and 9 buildings.

### ND3.2 Access to buildings

Access for people with disabilities must be provided to buildings as set out in Table ND3.2 by means of a continuous path of travel in accordance with AS 1428.1, or NZS 4121 and NZS 4122 –

(a) from the boundary of the allotment:

- (b) from any carpark space on the allotment (whether within or outside the building)–
  - (i) that is set aside for people with disabilities using the building; or
  - (ii) if there are no carpark area that serves the building; and
- (c) from any other building on the allotment to which access for people with disabilities is *required*.

**TABLE ND3.2  
REQUIREMENTS FOR ACCESS FOR PEOPLE WITH DISABILITIES**

CLASS OF BUILDING	ACCESS REQUIREMENTS
<p><b>Class 3</b></p> <p>(a) If the building contains –                      more than 10 units up to 49 units                      more than 49 but not more than 99                      more than 99 units</p> <p>(b) If accommodation is provided for more than 10 persons other than in <i>sole-occupancy units</i> –</p> <p>up to 49 beds                      more than 49 but not more than 99                      more than 99</p> <p>(c) Common areas of buildings that are required to be accessible ... ..</p>	<p>To and within –</p> <p><i>one sole-occupancy unit</i>  <i>2 sole-occupancy units</i>  <i>3 sole-occupancy units.</i></p> <p>2 beds                      4 beds                      6 beds</p> <p>the entrance floor and to all public areas on that floor</p>
<p><b>Class 5 and 6</b> ... ..</p>	<p>To and within the entrance floor if its <i>floor area</i> is more than 500 m2.</p>
<p><b>Class 7</b> ... ..</p>	<p>To and within the entrance floor if the total <i>floor area</i> of the building is more than 3000 m2.</p>
<p><b>Class 8</b> ... ..</p>	<p>To and within the entrance floor if the total <i>floor area</i> of the building excluding any part used as a laboratory, is more than 1000 m2.</p>
<p>AND</p> <p><b>Class 5, 6, 7 and 8</b> ... ..</p>	<p>To and within any floor if irrespective of <i>floor area</i>, the floor is not more than 190mm at the point of entrance above or below the adjacent finished ground level; and</p> <p>Within any other floor to which vertical access by way of a ramp, step or kerb ramp, or passenger lift is provided.</p>

**TABLE ND 3.2 Continued**  
**REQUIREMENTS FOR ACCESS FOR PEOPLE WITH DISABILITIES**

CLASS OF BUILDING	ACCESS REQUIREMENTS
<b>Class 9a</b>	To and within all areas normally accessible to the public, patients or staff.
<b>Class 9b –</b> <i>An assembly building not being a school or an early childhood centre</i> ....	To and within every room that accommodates more than 100 persons, and if fixed seating is provided, not less than 1 wheelchair space for each 200 seats, or part, with a minimum of 2 spaces; and  within any other floor to which vertical access by way of a ramp, step or kerb ramp, or passenger lifts is provided.
<i>An early childhood centre</i>	To and within every room used by children.
<p>Note: The calculation of <i>floor area</i> and the number of persons accommodated are in accordance with ND1.13.</p> <p>For the purposes of this Table, a double bed counts as 1 bed.</p>	

**ND3.3 Parts of buildings to be accessible**

- (a) Access for people with disabilities must be provided-
  - (i) from the doorway at the entrance floor providing access to any *sanitary compartment required* for the used of people with disabilities; and
  - (ii) to areas normally used by the occupants, excluding any plant room, commercial kitchen, cleaners, store room, maintenance accessway, rigging loft, or the like.
- (b) A path of travel providing *required access* must not include a stairway, turnstile, revolving door, escalator or other impediment which would prevent a person in a wheelchair using it.
- (c) Access, finishes and fittings, including passageways, ramps, step or kerb ramps, passenger lifts, signs, doorways and other

parts of the building required by this Part must comply at least with the provisions of AS1428.1 or NZS 4121 and NZS 4122, excluding any references to AS 1735.12.

**ND3.4 Concessions**

It is not necessary to provide access for people with disabilities –

- (a) to more than 30% of the public space in a restaurant, café, bar, function room, or the like, in a Class 6 or Class 9b building;
- (b) to a *mezzanine* floor or other space not regarded as a *storey* by definition;
- (c) to more than 1 car parking space for each 100 spaces in a *public carpark*; or
- (d) to any area if access would be inappropriate because of the particular purpose for which the area is used.

**PUBLIC BUILDINGS AND GROUP DWELLINGS (CLASS 2 TO 9)**

**SECTION NE**

---

**SERVICES AND EQUIPMENT**

---

**Performance Requirements  
Deemed-to-Satisfy Provisions**

- NE1 Fire Fighting Equipment**
- NE2 Smoke Control**
- NE3 Lift Installations**
- NE4 Emergency Lighting and Exit Signs**
- NE5 Maintenance of Safety Installations**
- NE6 Electricity**

---

## CONTENTS

### PERFORMANCE REQUIREMENTS

#### DEEMED-TO-SATISFY PROVISIONS

Part

**NE1 Fire Fighting Equipment**

- NE1.1 Application of Part
- NE1.2 Fire mains and water supply
- NE1.3 Riser main system
- NE1.4 Where hydrants are required
- NE1.5 Hose reels
- NE1.6 Sprinklers
- NE1.7 Portable fire extinguishers
- NE1.8 Fire and smoke alarms
- NE1.9 Fire control centres
- NE1.10 Fire precautions during construction
- NE1.11 Provision for special hazards

**NE2 Smoke Control**

- NE2.1 Smoke venting
- NE2.2 Exclusion of smoke from fire-isolated exits
- NE2.3 Natural smoke venting
- NE2.4 Air-handling systems
- NE2.5 Roof vents
- NE2.6 Smoke exhaust systems
- NE2.7 Pressurisation

**NE3 Lift Installations**

- NE3.1 Application of Part
- NE3.2 Stretcher facility in lifts
- NE3.3 Warning against use of lifts in fire or earthquake
- NE3.4 Emergency lifts

**NE4 Emergency Lighting, Exit Signs and Warning Systems**

- NE4.1 Application of Part
- NE4.2 Emergency lighting requirements
- NE4.3 Measurement of distance
- NE4.4 Design and operation of emergency lighting

Part

- NE4.5 Exit signs
- NE4.6 Direction signs
- NE4.7 Class 2,3 and 4 buildings: Exemptions
- NE 4.8 Design and operation of exit signs

**NE5 Maintenance of Safety Installations**

- NE5.1 Application
- NE5.2 Maintenance requirements

**NE6 Electrical Work**

- NE 6.1 Safety
- NE6.2 Amenity

**Specifications**

Specification NE1.2  
Fire Mains and Water Supply Services

Specification NE1.6  
Fire Sprinkler Systems

Specification NE1.8  
Fire Detection and Alarm Systems

Specification NE1.9  
Fire Emergency Control Centres

Specification NE2.4  
Air Handling Systems in Buildings

Specification NE2.6  
Smoke Exhaust Systems

---

## PERFORMANCE REQUIREMENTS

### OBJECTIVES

A building must be so designed and constructed that the following objectives are fulfilled:

#### NEP1 Fire Fighting Equipment

Having regard to the size and use of the building and its Type of construction, adequate in-built and external fire protection services must be provided to-

- (a) restrict fire growth to the compartment of origin;
- (b) prevent fire spread to adjoining buildings or allotments; and
- (c) facilitate the fighting of fire to minimise damage to the building and its contents.

#### NEP2 Smoke Control

Air-handling system installed in a building must-

- (a) provide suitable air for the health and safety of the occupants; and
- (b) incorporate reasonable measures to minimise the spread of smoke in the event of fire to escape paths from the building, to other compartments and to enable access by fire fighters.

#### NEP3 Lift Installations

Lifts where provided must have regard to the nature of any emergency –

- (a) to assist in the evacuation of the occupants; and
- (b) to facilitate access by fire-fighting and other emergency personnel.

#### NEP4 Emergency Lighting and Exit Signs

- (a) Emergency lighting and *exit* signs must be provided where necessary to facilitate safe egress in an emergency upon failure of the normal lighting.
- (b) Suitable alarm systems must be provided to alert occupants of an emergency, initiate *automatic* counter measures and summon emergency personnel.

#### NEP5 Maintenance of Safety Installations

Equipment, installations and components critical to the safety of the building or the occupants must be adequately maintained in such condition that will enable their proper performance.

#### NEP6 Electrical Work

All electrical work must meet the following objectives-

- (a) It must prevent electrocution, burns or fire.
- (b) It must satisfy the reasonable expectations of the users by ensuring that it is adequate for their intended use, both current and anticipated.

### REQUIRED PERFORMANCE

#### NEP1.1 Active fire fighting

In determining the type and extent of active fire fighting systems that must be provided for a building the following must be taken into account-

- (a) the class of occupancy;
- (b) proximity to *fire-source features*;
- (c) type of construction in relation to fire resistance;
- (d) size of fire compartments
- (e) *effective height*;
- (f) the flow rate and pressure of available water supply;
- (g) the capacity of the Fire Brigade or other fire fighting organization that serves the area where the building is located; and
- (h) the technical resources available locally to satisfactorily install and regularly test and maintain the active fire fighting system.

#### Fire and smoke alarms

Reliable detection and warning systems must be installed for *automatic* operation in the event of a fire or generation of unacceptable levels of smoke. In the case of-

- (a) all tall buildings;



- 
- (b) buildings of medium size or larger, frequented by the public and where flammable and consumer goods are displayed; and
  - (c) occupancies of excessive hazard of moderate size or larger.

the detection systems on initiation must automatically activate suitable fire fighting systems.

#### **NEP2.1 Smoke control**

Air handling systems in buildings must be no more complex than what is given in the Deemed-to-Satisfy Provisions unless satisfactory evidence is produced to show that the level of expertise available on an on-going basis would be adequate to keep them regularly tested serviced and maintained in a sound condition. Air handling systems must be such that smoke is not transported from the compartment or locally of origin to escape paths and other *fire compartments* or *storeys* to a concentration that might affect the safety of the occupants or hinder the work of fire fighters.

#### **NEP3.1 Lift Installations**

Lift installations in tall buildings must be capable of transporting stretches without discomfort. Effective warning must be displayed against the use of lifts during fires or earthquakes. In very tall buildings at least one lift must be such that it can be safely operated during emergencies such as fire and be switched during the emergency for operation by only emergency personnel such as fire fighters.

#### **NEP4.1 Emergency lighting**

In moderately tall or higher residential building, in other than small buildings where the occupants are transient, and in all other buildings emergency lighting must be provided to clearly indicate *exits* and the doors guarding such *exits* must be identifiably marked. Such buildings must also have emergency lighting available to facilitate the occupants to reach the *exits* without confusion and to safely negotiate the *exits* until they can be in a road or *open space*. The route to the *exits* must be identifiably marked. In hospitals and in areas where emergency personnel operate, there must be adequate emergency lighting to avoid patient trauma or hardship and to permit the staff to carry out emergency functions.

All emergency lighting must automatically operate in the event of any failure of normal lighting for a period

long enough for the evacuation of all the occupants, plus a margin. Such lighting must give an adequate level of illumination to allow evacuation without hindrance.

#### **NEP6.1.1 Electrical safety**

The supply system must:

- (a) have suitable devices of adequate interruptive duty to automatically shut off the supply in the event of a fault or overload. Such devices must allow easy reinstatement of the supply after interruption;
- (b) have devices which are clearly identified and easily reached to isolate live parts from the incoming supply;
- (c) be constructed and installed to ensure that no part of the system can be subjected to a voltage higher than that for which the system was designed;
- (d) when the neutral of the supply is earthed, have socket outlet or plug – socket adapter construction which would ensure that the live, neutral and earth conductors can only be connected to the corresponding live, neutral and earth conductors of the plug;
- (e) where it is common supply system be so compatible that the safety features of the system itself are not impaired;
- (f) where it has a multiple earthen neutral system, have an adequate connection between the neutral conductor and earth at each consumer's premises;
- (g) be adequately protected against damage arising from exposure to weather, water or excessive dampness mechanical loads and other such agents expected under normal conditions of use; and
- (h) ensure that the main switch is normally accessible only to the occupants.

#### **NE6.1.2 Amenity**

The supply system must have an adequate capacity to serve the reasonable anticipated needs of the users.

---

## DEEMED-TO-SATISFY PROVISIONS

### FIRE-FIGHTING EQUIPMENT

#### NE11.1 Application of Part

This Part applies to Class 2,3,4,5,6,7,8 and 9 buildings.

#### NE1.2 Fire mains and water supply

(a) Where a permanently charged *fire main* and water supply system are available these must provide a continuous supply of water at sufficient pressures and rates of flow to enable effective fire fighting on any adjoining building. The system must in addition have *hydrants* located free of obstructions at appropriate intervals. The location of the *hydrants* must be suitably marked for ease of identification by the fire service.

(b) In the case of buildings with a *rise* of 5 *storeys* or more where an adjoining permanently charged *fire main* and water supply system is not available, adequate on *site* water storage and suitable fire pumps must be provided to give the rates and pressures of flow for fire fighting, as per NZS4510. The system provided may in addition serve any *required sprinkler system* or other *required water* type in- built fire protection system.

(c) A *fire main* and water supply system must comply with Specification NE1.2

#### NE1.3 Riser main system

*Riser* mains to NZS4510 must be provided in buildings with a *rise* of 5 *storeys* or more. In buildings with a *rise* of up to 8 *storeys* a *charged dry riser main system* is allowable; for taller buildings a *wet riser main system* is *required*. Any *wet riser main system* must be connected to a permanently charged *fire main*. In buildings with a *rise* of more than 8 *storey* a dedicated automatic starting fire pump or pumps in accordance with NZS4510 must be installed in the system to boost the pressure and/or the rates of flow to the values *required* by the Standard.

#### NE1.4 Where hydrants are required

(a) General

One or more *hydrants* must be provided-

- (i) in each *storey* with a *floor area* of more than 750 m<sup>2</sup>;

(ii) in very *storey* if the building contains 5 *storeys* or more; and

(iii) on the roof if the building has a *rise* of more than 8 *storeys* except on

- a roof having a pitch of more than 10°; or
- a roof of a plant room or other subsidiary structure on the main roof.

(b) External *hydrants*

The configuration and location of a building and of adjacent external *hydrants* must be such that the farthest point on the *storeys* to which direct access from a street is available for the fire service, must be within reach of a 6m spray from the nozzle of a 120 m fire hose.

External *hydrants* must be located –

(i) not closer than 6 m from a building unless protected from it with wall having a FRL of not less than 60/60/30 extending at least 2 m each side and 3 m above the *hydrant outlets*; and

(ii) not more than 20 m unobstructed distance from hand standing access for a fire pump appliance.

(c) Internal *hydrants*

(i) The *riser main* system must provide for sufficient number and disposition of internal *hydrants* such that any point on any *storey* is within reach of a 6 m spray from the nozzle of a 45 m fire hose.

(ii) Internal *hydrants* must be located on the floor not more than 4 m from a *required exit*, or in a *required* stairway, passageway or ramp so as not to encroach on the required width of the exit.

(d) *Hydrants* for the ground floor of a building may be *external hydrants*.

#### NE1.5 Hose reels

Hose reels must be installed in buildings as listed in Table NE1.5 and must –

- (a) not be located –
  - (i) within a fire-isolated *exit*, or
  - (ii) so that the hose will need to pass through the doorway fitted with a fire or smoke door; except a door to a *sole-occupancy* unit in a class 2,3 or 4 building;

TABLE NE1.5 REQUIREMENTS FOR FIRE HOSE REELS	
OCCUPANCY	FIRE HOSE REELS REQUIRED
Class 2	if more than 4 residential <i>storeys</i> contained.
Class 3	if more than 2 residential <i>storeys</i> contained.
Class 5,6,7,8 or 9b	(a) any <i>storey</i> if <i>floor area</i> of <i>storey</i> more than 750m <sup>2</sup> ; or  (b) if more than 3 <i>storeys</i> contained
Class 9a	all buildings.
AND All Classes	Wherever an internal <i>hydrant</i> is required

- (b) be located –
  - (i) not more than 4 m from a *required exit* on each floor of the building (including the ground floor) and adjacent to any hydrants required within the building; and
  - (ii) so that the nozzle end of a fully extended fire hose fitted to the reel and laid to avoid any partitions or other physical barriers will reach every part of the floor.
- (c) serve only the floor on which they are located except that a hose reel may serve a *sole-occupancy* unit of not more than 2 *storeys*, or a unit with a *mezzanine floor*, if the hose reel is located at the level of egress from that unit; and
- (d) comply with AS/NZS1221 and NZS4503.

#### NE1.6 Sprinklers

A required *sprinkler system* must-

- (a) comply with Specification NE1.6; and
- (b) be installed in buildings as listed in Table NE1.6.

#### NE1.7 Portable fire extinguishers

Portable fire extinguishers containing an extinguishing agent suitable for the risk being protected must be installed in accordance with NZS4503 in all buildings except –

- (a) a Class 2 or 3 building; or
- (b) in the case of water-type extinguishers, a building or part of a building served by a fire hose reel.

TABLE NE1.6 REQUIREMENT FOR SPRINKLERS	
OCCUPANCY	WHEN SPRINKLERS ARE REQUIRED
Occupancies of excessive hazard	In <i>fire compartments</i> with  (a) a <i>floor area</i> of more than 2000m <sup>2</sup> ; or  (b) a volume more than 1000m <sup>3</sup> .
Class 6	In <i>fire compartments</i> with  (a) a <i>floor area</i> of more than 2000m <sup>2</sup> ; or  (b) a volume more than 12000m <sup>3</sup> .
All Classes except <i>open-deck carparks</i>	in buildings more than 25m in <i>effective height</i> or with a <i>rise</i> in excess of 8 <i>storeys</i> . The water supply for the <i>sprinkler system</i> must be to Class A.
Carparks, other than <i>open-deck carparks</i>	(a) if accommodating more than 40 vehicles;  (b) if incorporating structural steel members with a FRL less than 60/-/.
Note:	
(a) Occupancies of excessive fire hazard are listed in the annexure to Specification NE1.6.	
(b) See NC2.3 for requirements for sprinklers in large isolated buildings.	

Table NE1.7 shows the commonly available portable extinguishers and their selection for appropriate class and type of fires.

**NE1.8 Fire and smoke alarms**

**NE1.8.1** A suitable *automatic* fire and smoke alarm system complying with Specification NE1.8 must be installed in –

- (a) each *storey* if the building has a *rise* of 5 to 8 *storeys*;
- (b) a Class 3 building –
  - (i) if rooms for residential use are above a height of 2 *storeys*; or

- (ii) in a special accommodation house or home for the aged, children, sick or physically or mentally disabled persons or the like; and
- (c) a Class 9a building –
  - (i) if more than 20 patients are accommodated in wards or bedrooms; or
  - (ii) in a clinic or day surgery, having areas where surgical procedures are performed at a height of 3 *storeys* or more.

TABLE NE1.7 PORTABLE FIRE EXTINGUISHER SELECTION CHART					
		CONTENTS OF EXTINGUISHER ARE			
		Electrically Conductive		Electrically Non-Conductive	
Class and Type of Fire	Type of Extinguis her	WATER	FOAM	DRY CHEMICAL	CARBON DIOXIDE
<b>A</b>	Ordinary combustibles (wood, paper, etc)	4 YES MOST SUITABLE	4 YES	4 YES	4 YES
<b>B</b>	Flammable liquids	X NO	4 YES Special foam required for alcohol-type fire	4 YES	4 YES
<b>C</b>	Flammable gases	X NO	X NO	4 YES	4 YES
<b>D</b>	Combustible metals	X NO	X NO	X NO	X NO
USE SPECIAL PURPOSE EXTINGUISHERS ONLY					
<b>(E)</b>	Fire involving live electrical equipment	X NO	X NO	4 YES	4 YES

**NE1.8.2** A manually operated evacuation alarm system to the relevant provisions of Specification NE1.8 must be provided in any building of –

- (a) Class 3 containing more than 20 beds where the rooms for residential use are located up to a height of only 2 *storeys*.

- (b) Class 5 with a *rise* of 3 or 4 *storeys* and a *storey floor area* of more than 500 m<sup>2</sup>;
- (c) Class 6,7 or 8 excluding a *public carpark* with a *rise* of up to 4 *storeys* and a *storey floor area* of more than 500 m<sup>2</sup>;
- (d) Class 9(a) with a *rise* of up to 4 *storeys*; and

- 
- (e) In the residential part of a school accommodating more than 20 persons at a level above or below the entrance level. Also in all other class 9b buildings (including schools) with a rise of up to 4 storeys and a storey floor area of more than 250 m<sup>2</sup>; and

Type A,B,or C alarm systems are acceptable for Class 3 buildings, Type B or C for Class 6 and 9 other than schools, and a Type A system for Class 7 and 8 buildings and schools.

#### **NE1.9 Fire control centres**

A fire control centre facility in accordance with Specification NE1.9 must be provided in –

- (a) all buildings with an effective height of more than 25m; and
- (b) a Class 6,7,8 or 9 building with a total floor area more than 18000 m<sup>2</sup>.

#### **NE1.10 Fire precautions during construction**

In a building under construction –

- (a) not less than one fire extinguisher to suit Class A, B and C fires and electrical fires

must be provided at all times on each floor adjacent to each *required exit* or temporary stair or *exit* and;

- (b) after the building has reached an *effective height* of 12 m –
  - (i) the *required hydrants* and hose reels must be operational in at least every *storey* that is covered by the roof or the floor structure above, except the 2 uppermost *storeys*; and
  - (ii) *any required fire brigade booster connection* must be installed.

#### **NE1.11 Provision for special hazards**

Suitable additional provision must be made if special problems of fighting fire could arise because of –

- (a) the nature or quantity of materials stored, displayed or used in a building or on the allotment; or
- (b) the location of the building in relation to a water supply for fire fighting purposes.

## SMOKE CONTROL

### NE2.1 Smoke Venting

Buildings must have a system to control smoke as listed in Table NE2.1.

<b>TABLE NE2.1 REQUIREMENTS FOR SMOKE CONTROL</b>	
BUILDING	SYSTEM
<p><i>Sole-occupancy units</i> in Class 2,3 or 4 buildings.</p> <p>Single storey buildings where the <i>floor area</i> of a <i>fire compartment</i> or <i>storey</i> does not exceed 500m<sup>2</sup> and is not served by a central mechanical ventilation plant.</p>	No requirement
Single storey buildings, or the top storey of <i>multistorey</i> buildings	Either: (a) <i>Windows</i> , panels or the like in accordance with NE2.3; (b) Roof vents in accordance with NE2.5; or (c) Smoke exhaust systems in accordance with NE2.6.
Multistorey buildings excluding the top storey	<i>Windows</i> , panels or the like in accordance with NE2.3.
Class 6 buildings with enclosed malls exceeding 40 m in length	Smoke exhaust systems in accordance with NE2.6.

### NE2.2 Exclusion of smoke from fire-isolated exits

Smoke must be excluded from fire-isolated exits in accordance with Table NE2.2

<b>TABLE NE2.2 MEANS OF EXCLUDING SMOKE FROM FIRE-ISOLATED EXITS</b>	
EXIT TYPE	REQUIREMENT
<p>A <i>required fire-isolated stairway</i> serving any storey above an <i>effective height</i> of 25m.</p> <p>A <i>required fire-isolated stairway</i> serving 3 or more below ground storeys.</p> <p>A <i>required fire-isolated ramp</i> or <i>fire-isolated passageway</i> having a path of travel more than 60m along it to a road or <i>open space</i>.</p>	<p>Either –</p> <p>(a) a pressurisation system in accordance with NE2.7; or</p> <p>(b) open access ramps or balconies in accordance with ND2.5.</p>
<p>Note: A below ground storey is one where egress involves an upward vertical climb of more than 1.5m.</p>	

---

### NE2.3 Natural Smoke Venting

*Windows*, doors, panels, or the like, provided to control the movement of smoke must –

- (a) be as evenly distributed as practicable; and
- (b) be readily openable, except that if *windows* and panels or the like are provided on the ground level *storey*, they need only be shatterable.

### NE2.4 Air-handling Systems

If an air-handling system is installed in a building it must operate in accordance with Specification NE2.4.

### NE2.5 Roof Vents

*Required* roof vents must comply with AS2665, except that –

- (a) smoke curtains may divide the space below the roof into compartments with area not more than 1500m<sup>2</sup>.
- (a) all roof vents within the same compartment must open at the same time; and
- (b) roof vents must be activated by-
  - (i) except in a Class 7 or 8 building, *sprinkler system* if it is installed throughout the building; or
  - (ii) a fire detection and alarm system which complies with AS1670 or NZS 4512; or

- (iii) smoke detectors spaced not more than 30 m apart and 15m from any smoke curtain and with not less than one detector for each 500 m<sup>2</sup> of *floor area*; or

- (iv) rate of rise heat detectors spaced not more than 15 m apart and 7.5 m from any smoke curtain and with not less than one detector for each 250 m<sup>2</sup> of *floor area*.

### NE2.6 Smoke Exhaust Systems

A *required* smoke exhaust system must comply with Specification NE2.6.

### NE2.7 Pressurisation

A *required* pressurisation system must –

- (a) comply with AS/NZS1668.1, except that instead of the criterion of 50 Pa pressure differential across each door when all doors are closed it must be 25Pa;
- (b) not allow openable *windows* or other devices (other necessary doorways, pressure-controlled relief louvers and *windows* openable by a key) in the stairway, ramp or passageway; and
- (c) not serve more than one fire-isolated *exit* system and not form part of any other air-handling system.

---

## LIFT INSTALLATIONS

### NE3.1 Application of Part

This Part applies to Class 2,3,4,5,6,7,8 and 9 buildings.

### NE3.2 Stretcher facility in lifts

- (a) if passenger lifts are installed in any building with an effective height of more than 25 m, at least one lift serving all storeys of the building must have a stretcher facility in accordance with (b).
- (b) A lift *required* to comply with NE3.2 (a) or NE3.4 (b) must accommodate a raised stretcher with a patient lying on it horizontally by providing a clear space 600 mm wide x 2000 mm long x 1200 mm high above the floor level.

### NE3.3 Warning against use of lifts in fire or earthquake

A warning sign must –

- (a) be displayed where it can be readily seen –
  - (i) near every call button panel for a passenger lift or group of lifts throughout a building; except
  - (ii) a small lift such as a dumb-waiter or the like that is for the transport of goods only; and

- (b) comply with the details and dimensions of Figure NE3.3 and consist of-

- (i) incised, inlaid or embossed letters on a metal, wood, plastic or similar plate securely and permanently attached to the wall; or
- (ii) letter incised or inlaid directly into the surface of the material forming the wall.

### NE3.4 Emergency lifts

- (a) Among the lifts serving every storey of a building with an *effective height* of 75 m or more, at least one must be capable of being used as an emergency lift.
- (b) An emergency lift *required* by (a) must –
  - (i) Comply with AS1735.2;
  - (ii) Be of sufficient size to take a stretcher facility in accordance with NE3.2 (b); and
  - (iii) Have a rating of at least 612 kg.

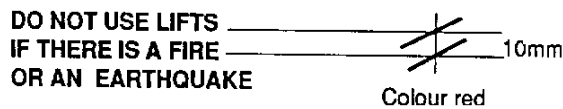

FIGURE NE3.3 WARNING SIGN FOR PASSENGER LIFTS

---



---

## EMERGENCY LIGHTING, EXIT SIGNS AND WARNING SYSTEM

### NE4.1 Application of Part

This Part applies to Class 2,3,4,5,6,7,8 and 9 buildings.

### NE4.2 Emergency lighting requirements

An emergency lighting system must be installed-

- (a) in every *fire-isolated stairway, fire-isolated ramp or fire-isolated passageway* located in Class 2 buildings of 5 storeys or more, Class 3 buildings containing 30 beds or more, a building with Class parts located at or higher than 15 m *effective height*, and in all Class 5,6,7,8 and 9 buildings;
- (b) in every storey of a Class 5,6,7,8 and 9 building where the storey has a *floor area* more than 500 m<sup>2</sup>
  - (i) in every passageway, corridor, hallway, or the like, which is part of the path of travel to an *exit*;
  - (ii) in any room having a *floor area* more than 250 m<sup>2</sup> if it does not open to a corridor or space which has emergency lighting;
- (c) in every passageway, corridor, hallway, or the like, having a length of more than 6 m from the entrance doorway of any *sole-occupancy unit* in a Class 2 building of 5 storeys or more, in a Class 3 building containing 30 beds or more, in a Class 4 part located at or above 15 m *effective height*, to the nearest doorway opening directly to-
  - (i) a *fire-isolated stairway, fire-isolated ramp or fire-isolated passageway*;
  - (ii) an external stairway serving instead of a smoke or *fire-isolated stairway* under ND1.8;
  - (iii) an external balcony leading to a *fire-isolated stairway, fire-isolated ramp or fire-isolated passageway*; or
  - (iv) a road or *open space*;
- (d) in every *required non-fire isolated stairway, ramp or passageway* connecting more than 3 consecutive storeys in other than Class 2 buildings;
- (e) in a *sole-occupancy unit* in a Class 5,6, or 9 building if-
  - (i) the *floor area* of the unit is more than 500 m<sup>2</sup>; and
  - (ii) an *exit* from the unit does not open to a road or *open space* or to an external stairway, passageway, balcony or ramp, leading directly to a road or *open space*;
- (f) in every room or space to which there is public access in every storey in a Class 6 or 9b building where-
  - (i) the *floor area* in that storey is more than 1000 m<sup>2</sup>;
  - (ii) any point on the floor of the storey is more than 30 m from the nearest doorway opening directly to a stairway, ramp, passageway, road or *open space*;
  - (iii) egress from that storey involves a vertical upward climb within the building of more than 1.5m; or
  - (iv) the storey provides a path of travel from any other storey required by (i), (ii), or (iii) to have emergency lighting;
- (g) in a Class 9a building-
  - (i) in every passageway, corridor, hallway, or the like, serving a ward area or patient treatment room: and
  - (ii) in every *ward area* or patient treatment room having a *floor area* of more than 200 m<sup>2</sup>; and
- (h) in every *required* fire control centre.

### NE4.3 Measurement of distance

Distances, other than vertical *rise*, must be the shortest measurement along the corridor or the path of travel whether by straight lines, curves or a combination of both.

---

**NE4.4 Design and operation of emergency lighting**

- (a) Emergency lighting systems must –
- (i) Be *automatic* in operation;
  - (ii) Provide sufficient illumination without undue delay for safe evacuation of all areas of the building where it is *required*;
  - (iii) If it is a central system, be suitable protected from damage by *fire*; and
  - (iv) Operate without interruption for a minimum of 1 hour.
- (b) Emergency lighting in accordance with AS/NZS2293 satisfies (a).

**NE4.5 Exit signs**

*Exit* signs must be installed and be clearly visible to persons approaching the *exit*, on or near-

- (a) every door providing direct egress from a *storey* to –
- (i) an enclosed stairway, passageway or ramp serving as a *required exit*;
  - (ii) an external stairway, passageway or ramp serving as a *required exit*; and
  - (iii) an external access balcony leading to a *required exit*;
- (b) every door from an enclosed stairway, passageway or ramp at every level of discharge to a road or *open space*;
- (c) every *horizontal exit*; and
- (d) every door serving as, or forming part of, a *required exit*.

**NE4.6 Direction signs**

If the *exits* will not otherwise be readily apparent to persons occupying or visiting the building, *exit* signs

with directional arrows must be installed in appropriate positions in corridors, hallways, lobbies, and the like, indicating the direction to a *required exit*.

**NE4.7 Class 2, 3 and 4 buildings: Exemptions**

NE4.5 does not apply to-

- (a) a Class 2 building in which every door referred to is clearly and legibly labelled on the side remote from the *exit* or balcony-
- (i) with the word “EXIT” in capital letters 25 mm high in a colour contrasting with that of the background; or
  - (ii) by some other suitable method; and
- (b) an entrance door of a Class 2, 3 or 4 *sole-occupancy unit*.

**NE4.8 Design and operation of exit signs**

- (a) Every required *exit* sign must-
- (i) be clear and legible and have letters and symbols of adequate size;
  - (ii) be illuminated at a level sufficient for it to be clearly visible at all times when the building is occupied by any person having the right of legal entry to the building;
  - (iii) be installed so that if the normal power supply fails, emergency illumination is provided to the sign in the case of those buildings covered by NE4.2; and
  - (iv) if illuminated by an emergency lighting system incorporating wiring and a power source, comply with NE4.4.
- (b) *Exit* signs in accordance with AS/NZS2293 satisfy (a).

## MAINTENANCE OF SAFETY INSTALLATIONS

### NE5.1 Application of Part

This Part applies to Class 2,3,4,5,6,7,8 and 9 buildings.

### NE5.2 Maintenance requirements

Safety installations in buildings must be adequately maintained to the requirements of Table NE5.2.

<b>TABLE NE5.2 SCHEDULE OF MAINTAINED ITEMS</b>	
ITEM TO BE INSPECTED OR TESTED	NATURE OF INSPECTION AND/OR TEST, AND FREQUENCY
<b>1. OPENING PROTECTION</b>	
A <i>required</i> fire door, <i>fire window</i> , fire shutter; or smoke door	Operate and inspect for compliance with the provisions of Part NC3 and Specification NC3.4  Monthly
<b>2. MEANS OF EGRESS</b>	
(a) <i>Exits</i> and paths of travel including doors, doorways and <i>exit</i> signs	Inspect to ensure compliance with Section ND  Monthly
(b) <i>Required</i> handrails and balustrades	Annually
(c) Arrangements for safe egress in buildings with special security provisions	Monthly
<b>3. SIGNS</b>	
(a) Signs concerning use of lifts in the event of fire	Inspect for legibility and installation in compliance with Part NE4  Annually
(b) <i>Exit</i> sign illumination - Internally illuminated signs	Check that the lamp matches the approved lamp rating marked on the sign fitting  Monthly
Externally illuminated signs	Check that the illumination is adequate  Monthly
<b>4. EMERGENCY LIGHTING</b>	
<i>Required</i> emergency lighting	(a) Operate in conditions of simulated failure of power to the distribution board concerned and check for compliance with the provisions of Part NE4  Monthly  (b) Where batteries are involved – Test and inspect as prescribed in AS1670 as though they are installed pursuant to the provisions of that Standard or where AS1670 is not relevant, test or inspect as appropriate  Monthly  (c) Check battery charger for correct operation  Monthly

<b>5. FIRE-FIGHTING SERVICES &amp; EQUIPMENT</b>	
(a) <i>Required</i> portable fire extinguishers	As prescribed in NZS4503
(b) <i>Required</i> fire hose reels	As prescribed in NZS4503
(c) <i>Required</i> hydrants and riser main system	As prescribed in NZS4510
<b>6. SPRINKLERS</b>	
(a) <i>Required sprinkler system</i>	As prescribed in NZS4541
(b) Plans containing reference information	Inspect for presence and legibility to comply with NZS4541
<b>7. AIR-HANDLING SYSTEMS</b>	
(a) Simulate activation of detectors	Operate and check for correct operation in accordance with Specification NE2.4 and NE2.6. Ensure that the system is left in correct operating condition  As in NZS4512
(b) Detectors	Test and inspect as though they are prescribed for installations under NZS4512
Associated batteries	Check battery charger for correct operation As in NZS4512
(c) Fire situations	Check to ensure compliance with AS/NZS1668.1 Annually
(d) Fire-control panels	Test and inspect as though the panel is installed as a Fire Indicator Board under NZS4512 As in NZS4512
(e) Pressurising of stairs, ramps and passageways	Operate, test and inspect to ensure compliance with AS/NZS1668.1 Monthly
<b>8. MANUAL FIRE ALARMS</b>	
	Operate to see if in working order As in NZS4512
<b>9. AUTOMATIC FIRE ALARMS</b>	
(a) <i>Required automatic</i> alarms	As prescribed in NZS4512
(b) Special situations and precautions and outdoor applications	Inspect for compliance with NZS4512
<b>10. LIFTS</b>	
Lifts and associated equipment for operation in event of emergency	Operate under simulated emergency conditions and check for compliance with the provisions of NE3  Quarterly
<b>11. STRUCTURAL FIRE PROTECTION</b>	
Compartmentation and fire protection of structural members	Ascertain that any work performed or any occurrence, accidental or otherwise, has not resulted in any reduction in the FRL or other fire protection provision of any part of the building installed as required  Annually

---

## ELECTRICAL WORK

### NE6.1 Safety

#### NE6.1.1 General Requirements

All electrical wiring and installations in or on any Class 2 to 9 building must ensure safety from electric shock and fire. This requirement is satisfied if all electrical work associated with the building is done to comply with AS/NZS3000 – Electrical installations – buildings, structures and premises (known as the SAA Wiring Rules). The capacity of the system must allow for the long term anticipated requirements of the occupants.

#### NE6.1.2 Plug and power sockets

Plug and power sockets must:

- (a) have their individual switch;
- (b) be located so that
  - (i) cords and cables need to be taken across doorways;
  - (ii) trailing cords and cables do not have to cross circulation routes;
- (c) not be located behind door-swings; and

- (d) in the kitchen in Class 2,3 and 4 buildings be located 250mm above worktops at the back of benches or on a return wall where it exists.

#### NE6.1.3 Meter and distribution board

The meter must be located in a position from which it can easily be read. If the main switches and circuit breakers/fuses are not located with the meter they must be located at a height of not less than 1.8m from the floor where they can be found easily in the dark.

### NE6.2 Amenity

#### NE6.2.1 Light switch layout

- (a) The layout of light switches in Class 2,3 or 4 buildings must follow the main night time circulation routes such as from the entrance hall to the living area to the bed-rooms to the bathroom and toilet. Crossing any major space in the dark must be avoided. The switches must be located close to door openings.
  - (b) All stairs must have two-way switching at the top and the bottom.
-

## FIRE MAINS AND WATER SUPPLY SERVICES

### 1. Scope

This specification refers to *fire mains* and water supply services for fire-fighting equipment in buildings.

### 2. General requirements

A *fire main* must –

- (a) be capable of supplying water at the flow rates and pressures necessary for the satisfactory operation of the *required* fire-fighting equipment;
- (b) not incorporate plastic pipes above ground; and
- (c) not be used for other than fire-fighting purposes, except a *fire main* serving only hose reels may be connected to a metered supply if-
  - (i) the *required* flow rate and pressure can be maintained at the most hydraulically disadvantaged hose reel;
  - (ii) the water meter and street supply to the allotment have a nominal diameter of not less than 32 mm;
  - (iii) water supply pipework reticulation arrangements comply with figure 2 or a similar arrangement; and
  - (iv) any system valve which can isolate flow in the *fire main* is secured in the open position by a pad locked metal strap.

In buildings with a *sprinkler system* with a dual supply to Class A of NZS4541 the water supply to any *wet riser main system* and/or hose reels may be taken from one of those adequate for both or all three purposes.

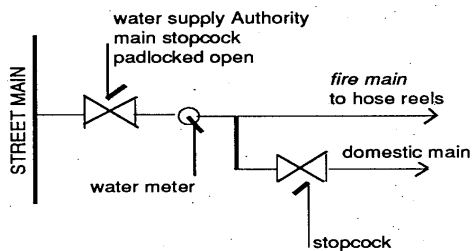

FIGURE 2 WATER SUPPLY RETICULATION:  
COMBINED SERVICES

### 3. Water supplies for sprinkler systems

All water supplies for *sprinkler systems* must satisfy the requirements of NZS4541. Further-

- (a) a Class C single supply system must comprise-
  - (i) a street main which may be boosted by a diesel fire pump unit;
  - (ii) on-site storage or any source allowed by the Standard; or
  - (iii) a combined supply from two street mains which individually are inadequate; and
- (b) a Class A dual supply system must include-
  - (i) a street main which may be boosted by a diesel fire pump or, any other primary source; and
  - (ii) a separate on-site storage or other source allowed by the Standard, with an independent electric or diesel fire pump.

### 3. Fire pump enclosures

Fire pumps must be located in a room or enclosure which has a FRL of not less than 60/60/30 and is-

- (i) within the building; or
- (ii) external but not within 6 m of the building and any *fire-source feature*.

### 4. Booster and charged dry riser main connections and cabinets

- (a) Each *fire brigade booster connection* and the fire service inlet connection for a *charge dry riser main system* must be in locked cabinets accessible only to the fire service. If the system is fitted with a pressure gauge, the gauge must comply with AS1349, and have a full scale reading of not less than 25% more than the pressure to which the system has been *hydrostatically* tested.

- (b) Cabinets may be located –
  - (i) at the *external wall* of a building if they are within sight of the main entrance and for Class 6,7,8, or 9b buildings, separated from the building by construction having a FRL of not less than 60/60/30 for not less than 2 m each side of and above the top of the cabinet;

- 
- (ii) remote from the building if they are at the boundary of the allotment, within sight of the main entrance to the building, adjacent to the building, adjacent to the building, adjacent to the building;
- (iii) in any other suitable position.
- (c) A permanent fade and water resistant plan, equal to photo-engraved anodized aluminum, must be displayed in a prominent position within the cabinet, showing the following information:
- (i) the layout of the building and adjacent streets;
- (ii) the layout of the fire *hydrant* system reticulation with supply authority street mains and size, location of street and allotment *hydrants*, fire hose reels, booster connections, street and allotment isolating and principal vehicular access to the allotment and located not less than 10 m from the *external wall* of any building; or non-return valves, pump sand tanks;
- (iii) the operational discharge pressure and pressure at zero flow of any pump installed in the system;
- (iv) the capacity of any tank connected to the system;
- (v) the height of the highest *hydrant* outlet above the lowest booster inlet connection; and
- (vi) the year of installation of the system.
- (d) Suitable provision must be made for the drainage of water from within a booster or *charged dry riser main* system cabinet.
-

---

## FIRE SPRINKLER SYSTEMS

### 1. Scope

This specification sets out requirements for the design and installation of *automatic fire sprinkler systems*.

### 2. Adoption of NZS4541

An *automatic fire-sprinkler system* and associated water supply must comply with NZS4541 subject to this Specification. For further details of water supply requirements see Specification NE1.2

### 3. Interpretation

A reference to FRR in NZS4541 means FRL as defined in this code.

### 4. Definition of a sprinklered building

Notwithstanding NZS4541, a building or a part of a building is deemed to be sprinklered if –

- (a) in the case of a whole building, the building complies with section NC of this Code and is sprinklered throughout; or
- (b) in the case of a part of a building
  - (i) the part is sprinklered throughout and fire-separated from the

unsprinklered part in accordance with Part NC2; and

- (ii) any opening in the fire separating construction between the sprinklered and unsprinklered parts is protected in accordance with Part NC3.

### 5. Exceptions

Where a building or part of a building is required to be sprinklered throughout, the exceptions nominated in clause 207 of NZS4541 apply, except that a fire door in accordance with Part NC3 must be used for protection of openings.

### 6. Sprinkler valve enclosures

Sprinkler alarm valves must be located in a secure enclosure or room of adequate size, and where the valves are located within a building, the enclosure and *required* access to it must be suitable for the Fire Service.

### 7. Connection to evacuation alarm

The *sprinkler system* must be appropriately connected to any evacuation alarm system in the building to initiate the alarm in the event of activation of any sprinkler head.



---

## OCCUPANCIES OF EXCESSIVE FIRE HAZARD

This annexure contains a graded list of examples of excessive fire hazard. The examples do not cover all possibilities and therefore there could be many other occupancies of excessive fire hazard. The Fire Authority having jurisdiction must be consulted in case of any doubt about occupancies not included in this Annexure.

### ORDINARY HAZARD OCCUPANCIES

#### Group III Special

Flash fires are likely to occur in these occupancies. These include the following:

Chemical works and chemists (manufacturing or analytical) producing or using flammable solids, liquids, dusts and the like	Exhibitions
Copra kilns	Fibre glass products manufactures
Cork factories	Film and television studios
Cotton mills (preparatory processes)	Flax and hemp scutch mills
	Flax, jute and hemp mills (preparatory processes)
Distilleries (stillhouses)	Match factories
	Oil mills (crushing and solvent extraction)

### EXTRA HIGH HAZARD OCCUPANCIES

#### Process risks

Examples of extra high hazard process risks are as follows:

Aircraft hangars	Foam rubber and foam rubber goods Manufacturers and warehouses
Celluloid manufacturers and celluloid goods manufacturers	LPG bulk storage
Fire lighter manufacturers	Paint, colour and varnish works
Fireworks manufacturers	Resin, lamp black and Turpentine manufacturers
Floor cloth and linoleum manufacturers	Rubber substitute manufacturers
Foam plastics and foam plastics good manufacturers and warehouses	Tar distillers
	Woodwool manufacturers

#### High piled storage risks

Extra high hazard high piled storage risks are subdivided into four categories. Fires in materials belonging to categories II, III and IV produce exceptionally intense fires with a high rate of heat release. The four categories are:

**(a) Category I.** Category I comprises ordinary combustible materials and non-combustible materials in combustible wrappings, excluding those items specified under Categories II, III and IV, stored in bulk, in pallets or on racking, to heights exceeding 4m.

---

Examples of Category I storage are as follows:

Carpets Clothing	Groceries (items, not packaged)
Electrical appliances	Metal goods (in cartons)
Fibreboard (high density Hardboard)	Textiles
Glassware and crockery (in cartons)	All forms of paper storage other than those specified under Categories II and III

**(b) Category II** Examples of Category II storage are as follows:

Aerosol packs with flammable contents	Linoleum products
Baled cork Baled waste paper	Palletized whisky stocks Plastics (non-foamed) other than celluloid
Cartons and carton flats Cartons containing alcohols In cans or bottles Cartons of canned lacquers (which dry by solvent evaporation)	Rolled pulp and paper (horizontal storage) Rolled asphalt paper (horizontal storage)
Chipboard	Veneer sheets
Fibreboard (low density Soft board)	Wood patterns Wooden furniture

**(c) Category III** Examples of Category III storage are as follows:

Bitumen coated or wax Coated paper	Rolled asphalt paper (vertical storage)
Celluloid	Rubber goods
Esparto (loose)	Ventilated wood stacks
Flammable liquids in combustible containers Foamed plastics and foamed rubber products (with or without cartons) other than those specified in Category IV	Waxed or asphalt coated paper and containers in cartons  Woodwool Wooden pallets and wooden flats (idle)
Rolled pulp and paper (vertical storage)	All materials having wrappings or preformed containers of foamed plastics

**(d) Category IV** Examples of Category IV Storage are as follows:

Rolls of sheet foamed plastics or foamed rubber	Off-cuts and random pieces of foamed plastics or foamed rubber
--	---

---

## FIRE DETECTION AND ALARM SYSTEMS

### 1. Scope

This specification describes the installation and operation of *automatic* fire detection and alarm system, and manually operated evacuation alarm systems. The *automatic* systems may also be used to operate a smoke control system within a building.

### 2. Automatic systems

An *automatic* fire detection and alarm system must comply with NZS4512 subject to this Specification.

#### 2.1 Purpose

The purpose of a fire detection and alarm system is to-

- (a) warn the occupants of any fire within the building;
- (b) alert the local Fire Service; and
- (c) activate any installed *automatic* smoke control system; and
- (d) provide for manual operation as an evacuation system.

#### 2.2 Connection to extinguishing systems

Systems designed to NZS4512 for the actuation of any fire extinguishing system must operate on a dual circuit to permit *automatic* operation of an evacuation alarm.

#### 2.3 Location of smoke detectors

Smoke detectors must be –

- (a) wherever possible, surface mounted and external to air-conditioning and ventilation ducts, unless a point sampling system with maximum sensitivity level of 0.5% smoke obscuration is used;
- (b) located at natural collection points for hot smoke having regard to the ceiling geometry and its effects on the migratory path;
- (c) situated no closer than 3 m from smoke doors or fire doors; and
- (d) of the photo-electric type if installed within ducts or atmospheres contaminated with sub-micron dust and other particles likely to set off an ionization type detector.

### 2.4 Threshold levels

- (a) Sampling systems must comply with AS1670, with response times and alarm thresholds maintained at minimum levels and no alarm delay permitted on the highest alarm threshold.
- (b) The setting of alarm threshold levels for addressable detectors used within intelligent systems must not exceed the sensitivity levels nominated in-
  - (i) AS/NZS1668.1; and
  - (ii) NZS2139

### 3. Manually operated evacuation fire alarm systems

- (a) *Required* manually operated evacuation alarm systems must comply with NZS4512 for installation, operation and maintenance. The three systems considered are-

Type A - Simple mechanical means;

Type B - Simple electrical system, not monitored; and

Type C - Electrical systems continuously monitored by connection to the fire service station.

- (b) When Type B systems are installed, the following warning notice must be clearly marked near each manual call point-

**NOT CONNECTED TO A FIRE SERVICE IN CASE OF FIRE PHONE -----**

showing the telephone number of the fire authority in the locality.

type B systems may be substituted with a self-contained battery operated system, provided care is taken to ensure that the battery has sufficient charge available at all times.

- (c) Location

Manual call points must be located not more than –

- (i) for Class 3 buildings, 20 m from the doorway of any *sole-occupancy unit*;
- (ii) for Class 5,6,7,8 and 9b buildings, 20 m travel distance from any point on the floor; and

---

(iii) for Class 9a buildings-

- 12 m from any point of the floor of a *ward area*; or
  - 6 m from the entrance doorway of any room which may be occupied by a sleeping sedated or dependant patient.
-

---

## FIRE EMERGENCY CONTROL CENTRES

### 1. Scope

This specification describes the construction and contents of *required* fire-control centres or rooms.

### 2. Purpose and content

A fire-control centre or room must-

- (a) provide an area from which fire fighting operations or other emergency procedures can be directed or controlled;
- (b) contain controls, panels, telephones, furniture, equipment and the like associated with the *required* fire services in the building; and
- (c) not be used for any purpose other than the control of-
  - (i) fire fighting activities; and
  - (ii) other measures concerning the safety or security of the building occupants.

### 3. Location of fire-control centre or room

A fire-control centre or room must be so located in a building that egress from any part of its floor, to a public road or open space, does not involve changes in level which in aggregate exceed 300 mm.

### 4. Construction

A fire-control centre in a building more than 50 m in *effective height* must be in a separate room where –

- (a) the enclosing construction is of concrete, masonry or the like, sufficiently impact resistant to withstand the impact of any likely falling debris, and with a FRL of not less than 120/120/120;
- (b) any material used as a finish, surface, lining or the like within the room complies with the requirements for *fire-isolated stairways* in Specification NC1.6.
- (c) services, pipes, ducts and the like that are not directly required for the proper functioning of the fire-control room do not pass through it; and
- (d) openings in the walls, floors or ceiling which separate the room from the interior of the building are confined to necessary doorways, ventilation and other openings for

services, necessary for the proper functioning of the facility.

### 5. Protection of openings

Openings permitted by clause 4 must be protected as follows:

- (a) Openings for *windows*, doorways, ventilation, service pipes, conduits and the like, in and *external wall* of the building that faces a public road or *open space*, must be protected in accordance with Part NC3 as applicable.
- (b) Openings in the floors, ceilings and *internal walls* enclosing a fire-control room must, except for doorways, be protected in accordance with Part NC3, as appropriate.
- (c) A door opening in the *internal walls* enclosing a fire-control room, must be fitted with a *self-closing* 120/120/30 smoke sealed fire door.
- (d) Openings associated with natural or mechanical ventilation must-
  - (i) not be made in any ceiling or floor immediately above or below the fire-control room; and
  - (ii) be protected by a 120/120/- fire damper if the opening is for a duct through a wall *required* to have a FRL, other than an *external wall*.

### 6. Exit doors

- (a) *Required* doors to a fire-control room must open into the room, be lockable and located so that persons using escape routes from the building will not obstruct or hinder access to the room.
- (b) The fire-control room must be accessible via two paths of travel-
  - (i) One from the front entrance of the building; and
  - (ii) One direct from a public place or *fire-isolated passageway* which leads to a public place and has a FRL of not less than 120/120/120.

---

## 7. Size and contents

- (a) A fire-control room must contain not less than-
- (i) a Fire Indicator Panel and necessary control switches and visual status indication for all *required* fire pumps, smoke control fans and other *required* fire safety equipment installed in the building;
  - (ii) a telephone directly connected to an external telephone exchange;
  - (iii) a blackboard or whiteboard not less than 1200 mm wide x 1000 mm high;
  - (iv) a pin up board not less than 1200 mm wide x 1000 mm high; and
  - (v) a raked plan layout table of size not less than the plans to be laid out upon the table, and plans of the structural, architectural, electrical, mechanical, lift and fire service details which may be stored beneath the plan layout table or within other suitable storage facility located in the room.
- (b) In addition, a fire-control room may contain-
- (i) master emergency control panels, left annunciator panels, remote switching controls for gas or electrical supplies and emergency generator backup; and
  - (ii) building security, surveillance and management systems if they are completely segregated from all other systems.
- (c) A fire-control room must-
- (i) have a gross area of not less than 10 m<sup>2</sup> and the length of any internal side must be not less than 2.5 m;
  - (ii) if only the minimum prescribed equipment is installed have a net *floor area* of not less than 8m<sup>2</sup> with a clear space of not less than 1.5m<sup>2</sup> in front of the Fire Indicator Panel; and

- (iii) if additional equipment is installed, have an additional area of not less than 2 m<sup>2</sup> net *floor area* for each additional facility and a clear space of not less than 1.5 m<sup>2</sup> in front of each additional control or indicator panel,

and the area *required* for any path of travel through the room to other areas must be provided in addition to the requirements of (ii) and (iii).

## 8. Ventilation and power supply

A fire-control room must be ventilated by-

- (a) natural ventilation from a *window* or doorway in an *external wall* of the building which opens directly into the fire-control room from a roadway or *open space*; or
- (b) a pressurizing system that only serves the fire-control room, and-
  - (i) is installed in accordance with AS/NZS1668.1 as though the room is a *fire-isolated stairway*;
  - (ii) is activated *automatically* by operation of the fire alarm or *sprinkler system* installed in the building and manually be an over-riding control in the room;
  - (iii) provides a flow of fresh air through the room of not less than 30 air changes per hour when the system is operating and any door to the room is open;
  - (iv) has fans, motors and ductwork that form part of the system but not contained within the fire-control room protected by enclosing construction with a FRL of not less than 120/120/120; and
  - (v) has any electrical supply to the fire-control room or equipment necessary for its operation connected to the supply side of the main disconnection switch for the building and electrical service cables of copper-sheathed mineral-insulated cable with copper conductors,

an no openable *window* or other openable device other than necessary doorways, pressure controlled relief louvres and *windows* openable by a key, must be provided in the fire-control room.

## 9. Sign

---

The external face of the door to the fire-control room must have a sign with the words.

**Fire Control Room**

in letters not less than 50 mm high and colour which contrasts with that of the background.

**10. Lighting**

Emergency lighting in accordance with Part NE4 must be provided in a fire-control room, except that an illumination level of not less than 400 Lux must be maintained at the surface of the plan table.

**11. Equipment not permitted within a fire-control centre or room**

An internal combustion engine, pumps, sprinkler control valves, pipes and ancillary fittings must not be located in a fire-control centre or room, but may be located in rooms accessed through the fire-control centre or room.

**12. Ambient Sound Level**

The ambient sound level within the fire-control centre or room measured when all fire safety equipment is operating in the manner in which it operates in an emergency, must not exceed 65 dB(A), when determined in accordance with AS2107.

---

## AIR HANDLING SYSTEMS IN BUILDINGS

### 1. Scope

This specification outlines the performance and operation of mechanical ventilation and air-conditioning systems as they relate to smoke control in buildings.

### 2. Commonly Used Systems

The following commonly used systems may be installed:

- (a) small stand-alone or *window* units without ducting;
- (b) central chilled water systems with fan coil units located in each *storey* without any ducting;
- (c) central chilled water systems with separate air handling plants in each *storey* or *fire compartment* and associated independent ducting for the *storey* or *fire compartment*;
- (d) individual packaged plants an associated ducting for each *storey*; or
- (e) central plant where all the conditioning is done and with the ducting system connecting several *fire compartments* or *storeys*.

### 3. Action on Detection of Smoke Fire or Flame

In the case of small units the power supply to the units must be switched off manually. With all other systems immediately on activation of any of the detection units-

- (a) the total system for the whole building must shut down;
- (b) any *required exit* pressurisation system must operate; and
- (c) any *required* smoke exhaust system or *smoke-and-heat vent* must operate.

### 4. Compliance

The action required under 3 (a), (b) or (c) must be *automatic* and be activated by:

- (a) smoke detectors located in each *storey* or *fire compartment* in accordance with Specification NE1.8 and with ducted systems, located just upstream of the supply fan as well as in the main return air duct; or
  - (b) by any other suitable fire alarm system including a *sprinkler system*, installed within the building.
-



## SMOKE EXHAUST SYSTEMS

### 1. Scope

This specification describes the performance and method of operation of smoke exhaust systems in building which are designed to-

- (a) remove smoke from within the building using ducted or roof mounted exhaust fans; or
- (b) in a shopping centre complex or mall, remove smoke from within pedestrian malls to maintain for as long as possible a tenable

escape path for the occupants.

### 2. Fan capacity

Fan system must have an exhaust capacity in accordance with the height of the building as specified in Figure 2.

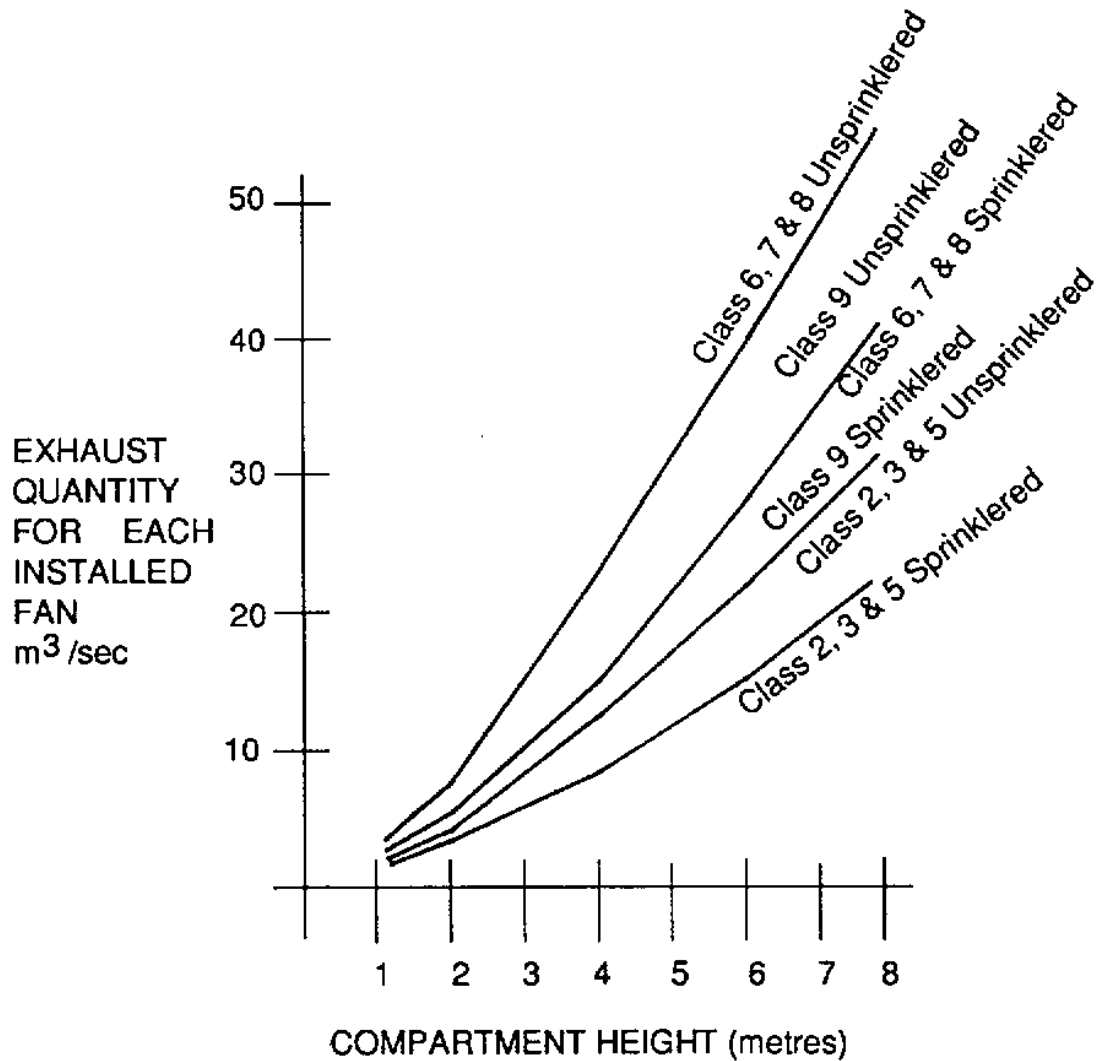

FIGURE 2 EXHAUST CAPACITY OF FANS

---

### 3. Compartmentation at ceiling level

The storey or room at ceiling level –

- (a) must be divided into compartments not more than 1500 m<sup>2</sup> in area by smoke curtains in accordance with AS2665; or
- (b) in a shopping centre complex or mall, must have-
  - (i) smoke curtains or, toughened or wired glass or *non-combustible* bulkheads, which extend not less than 1 m beneath an imperforate ceiling; or
  - (ii) ceiling coffers not less than 500 mm deep, each containing a smoke exhaust fan,

across the full width of the mall to divide it into lengths of not more than 40 m.

### 4. Location of fans and discharge

Exhaust fans must be located so as not to cause undue turbulence, and-

- (a) in a shopping centre complex or mall-
  - (i) be spaced no more than 40m apart and not more than 20m from the end of the mall;
  - (ii) not be at a mall intersection unless there is an open area where the ceiling is raised not less than 2m above the ceiling in the mall; and
  - (iii) be located at natural collection points for the hot smoky gases within each smoke compartment having regard to the ceiling geometry and its effects on the migratory path of the smoke;
- (b) in other buildings be located so that each fan must serve not more than one 1500 m<sup>2</sup> roof compartment; and
- (c) discharge directly to the outside and in a manner that will not spread fire or smoke to adjacent *fire compartments* or buildings.

### 5. Make-up air

Low level fresh air inlet openings or doors must be sized to provide adequate low velocity fresh air make up to satisfy the exhaust performance of the installed smoke exhaust fans, care being exercised in the number and location of such openings and their disturbance of the smoke layer due to turbulence created by the incoming air.

### 6. Operation of fans

All smoke exhaust fans must start sequentially and be activated by the operation in the area served by the fan of-

- (a) a *sprinkler system*;
- (b) a fire detection and alarm system which complies with Specification NE1.8;
- (c) a detector system comprising-
  - (i) smoke detectors spaced not more than 30 m apart and 15 m from any curtain, bulkhead or wall and with not less than one detector for each 500 m<sup>2</sup> of *floor area*; or
  - (ii) rate of rise heat detectors spaced not more than 15 m apart and 7.5m from any curtain, bulkhead or wall and with not less than one detector for a 250 m<sup>2</sup> of *floor area*,and not less than 2 detectors located on opposite sides of each fan inlet; or
- (d) in a shopping centre complex or mall-

- 
- (i) optical smoke detectors in each smoke compartment with at least one detector for each 150 m<sup>2</sup> of *floor area*, arranged in at least 2 groups so that on activation of an alarm group in the respective smoke compartment full exhaust is initiated, and on activation of a second group and following a 30 second check period an alarm is transmitted to the fire service station; and
  - (ii) a manual brace-glass alarm at each *exit* from a shop with a *floor area* of more than 1000 m<sup>2</sup> arranged to activate the exhaust system and transmit an alarm to the Fire Brigade.

**7. Protection of wiring**

Power supply wiring for roof-mounted exhaust fans must be MIMS (copper) cable or otherwise suitably fire-protected where it passes through other *storeys* and might be affected by fire remote from the floor served by the plant.

**8. Resistance to high temperatures**

If not adequately shielded from the airflow-

- (a) all parts of exhaust fans and other equipment *required* to operate in a smoke laden environment; and
- (b) parts of the building *required* to be smoke-resisting,

must be capable of withstanding a temperature of 200° C for a period of not less than 1 hour.

---

**PUBLIC BUILDINGS AND GROUP DWELLINGS (CLASS 2 TO 9)**

**SECTION NF**

---

**HEALTH AND AMENITY**

---

**Performance Requirements  
Deemed-to-Satisfy Provisions**

- NF1 Damp and Weatherproofing**
- NF2 Sanitary Facilities**
- NF3 Room Sizes**
- NF4 Light and Ventilation**
- NF5 Watersupply Plumbing**
- NF6 Sanitary Plumbing and Drainage**
- NF7 Roof Drainage**

---

## CONTENTS

### PERFORMANCE REQUIREMENTS

#### DEEMED-TO-SATISFY PROVISION

Part

**NF1 Damp and Weatherproofing**

- NF1.1 Site drainage
- NF1.2 Building on land subject to dampness
- NF1.3 Drainage of land external to building
- NF1.4 Weatherproofing of roofs and walls
- NF1.5 Pliable roof sarking
- NF1.6 Water proofing of wet areas in buildings
- NF1.7 Damp-proof courses
- NF1.8 Acceptable damp-proof courses
- NF1.9 Damp-proofing of floors on the ground

**NF2 Sanitary Facilities**

- NF2.1 Facilities in residential buildings other than Class 1 and 10
- NF2.2 Calculation of number of occupants and fixtures
- NF2.3 Facilities in Class 3 to 9 buildings
- NF2.4 Facilities for people with disabilities
- NF2.5 Construction of sanitary compartments
- NF2.6 Interpretation: Urinals and washbasins

**NF3 Room Sizes**

- NF3.1 Height of rooms
- NF3.2 Reduced height permissible
- NF3.3 Ceiling fans

**NF4 Light and Ventilation**

- NF4.1 Provision of natural light
- NF4.2 Methods and extent of natural lighting
- NF4.3 Natural light borrowed from adjoining room
- NF4.4 Artificial lighting
- NF4.5 Ventilation of rooms
- NF4.6 Natural ventilation
- NF4.7 Ventilation borrowed from adjoining room
- NF4.8 Restriction on position of WCs and urinals
- NF4.9 Airlocks

Part

- NF4.10 Sub-floor ventilation
- NF4.11 Public carparks
- NF4.12 Uncovered space for Class 4 parts

**NF5 Watersupply Plumbing**

- NF5.1 General requirements
- NF5.2 Means of compliance
- NF5.3 Pipes which are not easy to access
- NF5.4 Access to domestic-type water heaters

**NF6 Sanitary Plumbing and Drainage**

- NF6.1 General requirements
- NF6.2 Means of compliance
- NF6.3 Certain floors to be drained
- NF6.4 Grease trap
- NF6.5 Toxic wastes
- NF6.6 Small treatment plants

**NF7 Roof Drainage**

- NF7.1 General requirements
- NF7.2 Means of compliance

**Specifications**

Specification NF7.1

Sizing of Gutters and Downpipes

---

## PERFORMANCE REQUIREMENTS

### OBJECTIVES

A building must be designed and constructed to meet the following objectives –

#### **NFP1 Damp and Weatherproofing**

Suitable damp and weatherproofing must be provided where necessary to prevent-

- (a) moisture or damp affecting the stability of the building;
- (b) the creation of any unhealthy or dangerous condition; or
- (c) causing damage to adjoining property.

#### **NFP2 Cooking and Sanitary Facilities**

Adequate toilet and washing facilities must be provided for the occupants of a building, having regard to its use and size. In residential buildings other than those meant for transient occupants suitable facilities must also be available for the preparation and cooking of food, the cleaning of utensils and the laundering of clothes.

#### **NFP3 Room Sizes**

The *floor area*, plan dimensions and ceiling heights of rooms and other spaces within a building must be adequate for their use or purpose.

#### **NFP4 Light and Ventilation**

The standard of light and ventilation within a building must be adequate for the occupants, having regard to the use or purpose of the building.

#### **NFP5 Water Supply Plumbing**

An appropriate safe and hygienic system of plumbing for the supply of water for domestic needs must be provided.

#### **NFP6 Sanitary Plumbing**

An appropriate system of drainage for the hygienic waterborne conveyance of *waste water* must be provided.

#### **NFP7 Roof Drainage**

Where a roof drainage system is provided, it must give reasonable protection against the overflow of rainwater into the building.

#### **NFP9 Site Drainage**

Unhealthy ponding of water in the allotment must not be allowed and the erection of the building or any alteration to it must not adversely affect the drainage of other allotments or of any public land.

### REQUIRED PERFORMANCE

#### **NFP1.1 Damp and weatherproofing**

Water and damp conditions must not be allowed to –

- (a) affect the stability of buildings;
- (b) create ill health or discomfort for the occupants;
- (c) damage or deface buildings as a result of moisture present at the completion of construction; or
- (d) cause damage to adjacent property.

#### **NFP2.1 Cooking and sanitary facilities**

Any cooking facility provided must not spread smoke which may affect health or create a nuisance to the occupants or neighbours. Washing and clothes laundering facilities provided in residential buildings must be consistent with the size and occupancy of the building. The standard of toilet and washing facilities provided must in any building not create a nuisance or lead to ill health to the occupants or neighbours. These facilities must be located conveniently and the number of units provided must be consistent with the size and class of occupancy. Smoke extraction units from kitchens and other process operations in Class 6, 8 or 9 buildings must ensure that the progressive build-up of soot, grease and the like does not lead to a fire or unhealthy conditions.

#### **NFP3.1 Room sizes**

The size and disposition of rooms in a building must be consistent with the requirements of health and hygiene.

#### **NFP4.1 Light and ventilation**

Where airhandling systems are provided in a building there must be adequate provision for natural ventilation to cater for any prolonged failure of the system.

---

### **NFP5.1 Water supply plumbing**

Plumbing for potable water supply must use materials which do not react with the water and thereby make it unsuitable. Suitable precautions must be taken to ensure that unsafe or unhygienic material have no chance of entering the supply system. The installation of hot water systems must not impair the safety of the users. All concealed and difficult-to-access plumbing work must be suitably protected so that there is no likelihood of damage and leakage. The plumbing must take into account the current and anticipated needs of the user and allow for the simultaneous use of the connected system by others.

### **NFP6.1 Sanitary plumbing and drainage**

Sanitary plumbing must be laid to self-cleansing grades consistent with their discharge loading, unless other suitable arrangements are made to ensure that the system is kept free of the accretion of sewage and other waste matter. The size of drains and the layout of their connections must reasonably ensure the current and anticipated needs of the users. The connections to sanitary installations must ensure that foul gases are not allowed to produce unhygienic conditions nor create any nuisance to anyone and are suitably vented.

### **NFP7.1 Roof drainage**

The roof drainage system must be capable of handling peak intensities of rainfall as follows;

- (a) Eaves gutter and downpipe – a 20 year return intensity.
- (b) Internal box gutters, valley gutters and downpipes – a 100 year return intensity.

Any known local variation in rainfall intensity must be taken into account. Sufficient allowance must be made for the possibility of overflow into the building due to ripples and turbulence in the flowing water during cyclonic winds.

### **NFP9.1 Site drainage**

The immediate site around the building must have suitable drainage so that no ponding results. Visible water must not be allowed to remain under or around for more than 1 hour after 10 minutes of maximum rainfall resulting from a storm with a return period of 5 years. Flood waters or waves resulting from a storm or cyclone with a return period of 30 years must not be allowed to enter a building.

---

## DEEMED-TO-SATISFY PROVISIONS

### DAMP AND WEATHERPROOFING

#### NF1.1 Site drainage

The construction of a site drainage system and the position and manner of discharge of a stormwater drain must not-

- (a) result in the entry of water into any building or other allotment;
- (b) affect the stability of any building; or
- (c) create any unhealthy or dangerous condition within or around any building.

#### NF1.2 Building on land subject to dampness

One or more of the following measures must be carried out if it is warranted by the dampness of the building *site*:

- (a) the subsoil must be adequately drained.
- (b) the ground under the building must be regarded or filled and provided with outlets to prevent accumulation of water.
- (c) the surface of the ground under the building must be covered with a suitable damp-resisting material.

#### NF1.3 Drainage of land external to building

A suitable system of drainage must be provided if paving, excavation or any other work on an allotment will cause undue interference with the existing drainage of rainwater falling on the allotment whether the existing drainage is natural or otherwise.

#### NF1.4 Weatherproofing of roof and walls

Roofs and *external walls* (including openings for *windows* doors and the like) must be constructed to prevent rain or dampness penetrating to the inner parts of a building, unless it is –

- (a) a Class 7,8 or 10 building and in the particular case there is no necessity for compliance;
- (b) a garage, tool shed, *sanitary compartment*, or the like, forming part of a building used for other purposes; or
- (a) the lowest floor timbers and the walls above the lowest floor joists;

- (c) an *open spectator stand* or *open deck carpark*.

#### NF1.5 Pliable roof sarking

Pliable roof *sarking-type* material used under roof or wall covering must comply and be fixed in accordance with AS/NZS 4200.

#### NF1.6 Water proofing of wet areas in buildings

The following parts of a building must be impervious to water:

- (a) In any building – the floor surface or substrate in a shower enclosure, or within 1.5 m measured horizontally from a point vertically below the shower fitting, if there is no enclosure.
- (b) In a Class 3,5,6,7,8 or 9 building – the floor surface or substrate in a bathroom or shower room, slop sink compartment, laundry or *sanitary compartment* which is used in common by the occupants.
- (c) The wall surface or substrate-
  - (i) of a shower enclosure, or if the shower is not enclosed, within 1.5 m and exposed to a shower fitting, to a height of 1.8 m above the floor;
  - (ii) immediately adjacent or behind a bath, trough, basin, sink, or similar fixture, to a height of 300 mm above the fixture if it is within 75 mm of the wall.
- (d) The junction between the floor and wall if the wall and floor are *required* to be impervious to water.
- (e) The junction between the wall and fixture if the wall is *required* to be impervious to water.

#### NF1.7 Damp-proof courses

Except in a building that is exempt from weatherproofing under NF1.4, moisture from the ground must be prevented from reaching-

- (b) the walls above the damp-proof course; and



- 
- (c) the underside of a suspended floor constructed of a material other than timber, and the supporting beams or girders.

**NF1.8 Acceptable damp-proof courses**

A damp-proof course must consist of –

- (a) a material that complies with AS/NZS 2904
- (b) suitable termite shields placed on piers; or
- (c) other suitable material.

**NF1.9 Damp-proofing of floors on the ground**

If a floor of a room is laid on the ground or on filling-

- (a) moisture from the ground must be prevented from reaching the upper surface of the floor and adjacent walls by-
  - (i) the insertion of a vapour barrier in accordance with AS 2870.1; or
  - (ii) other suitable means; and
- (b) damp-proofing need not be provided if the building is exempt from weatherproofing under NF1.4

## SANITARY AND OTHER FACILITIES

### NF2.1 Facilities for residential buildings other than Class 1 and 10

Sanitary and other facilities for Class 2 and 3 buildings, and Class 4 parts of buildings, must be provided in accordance with Table NF2.1.

<b>TABLE NF2.1 PROVISION OF SANITARY AND OTHER FACILITIES</b>	
CLASS OF BUILDING	MINIMUM FACILITIES REQUIRES
<b>Class 2</b>	<p>Within each <i>sole-occupancy unit</i> –</p> <p>(a) a kitchen sink and facilities for the preparation and cooking of food;</p> <p>(b) a shower; and</p> <p>(c) a closet pan and facilities for washing hands.</p> <p>For each building –</p> <p>(a) a separate laundry for each 4 <i>sole-occupancy units</i>, or part without its own clothes washing facilities, comprising at least one washtub and space for a washing machine;</p> <p>(b) Clothes drying facilities comprising –</p> <p style="padding-left: 20px;">(i) lines or clothes hoists with not less than 7.5m of line per <i>sole-occupancy unit</i>; or</p> <p style="padding-left: 20px;">(ii) one heat-operated drying cabinet or appliance for each 4 <i>sole-occupancy units</i>, or part, without its own drying facilities.</p> <p>Facilities for employees –</p> <p>If the building contains more than 32 <i>sole-occupancy units</i>, or if a group of Class 2 buildings on the one allotment contains in total, more than 32 <i>sole-occupancy units</i> –</p> <p>a closet pan and washbasin in a compartment or room at or near ground level and accessible to employees without having to enter a <i>sole-occupancy unit</i></p>

**TABLE NF2.1** continued  
CLASS OF BUILDING      MINIMUM FACILITIES REQUIRED

<b>Class 3</b>	<p>Facilities for residents –</p> <p>For each 10 residents for whom private facilities are not provided –</p> <p>(a) a shower; and</p> <p>(b) a closet pan and washbasin, except that if one urinal is provided for each 25 males up to 50 and one additional urinal for each additional 50 males or part thereof, one closet pan for each 12 males may be provided.</p>
<b>Class 4</b>	<p>For each <i>sole-occupancy unit</i> –</p> <p>(a) a kitchen sink and facilities for the preparation and cooking of food;</p> <p>(b) a shower;</p> <p>(c) a closet pan and washbasin;</p> <p>(d) clothes washing facilities, comprising a washtub and space in the same room for a washing machine; and</p> <p>(e) a clothes line or hoist, or space for a heat-operated drying cabinet or similar appliance for the exclusive use of the occupants.</p>

### NF2.2 Calculation of number of occupants and fixtures

- (a) The number of persons accommodated must be calculated according to Table ND1.13 if it cannot be more accurately determined by other means.
- (b) Unless the premises are predominantly used by one sex or numbers of male and female users are known, sanitary facilities must be provided equally for both sexes.

In addition where the nature of employment of an employee is such that a shower is highly desirable at the end of the work (e.g. cooks and kitchen hands), showers must be

provided for each 10 such male or female employee in any one shift.

**NF2.3 Facilities in Class 3 to 9 buildings**

Sanitary facilities must be provided in Class 3,5,6,7,8 and 9 buildings in accordance with Table NF2.3.

<b>TABLE NF2.3 SANITARY AND OTHER FACILITIES</b>										
Class of Building	User	Max Number Served by –								
		Closet Fixture (s)			Urinals (s)			Washbasin (s)		
		1 Up to	2 Up to	Each Extra	1 Up to	2 Up to	Each Extra	1 Up to	2 Up to	Each Extra
3,5,6 and 9 other than schools	<b>Employees</b>									
	Males	20	40	20	25	50	50	60	120	60
	Females	15	30	15	-	-	-	60	120	60
7 & 8	<b>Employees</b>									
	Males	20	40	20	25	50	50	30	60	30
	Females	15	30	15	-	-	-	30	60	30
6 – Department stores, shopping centres and, individual shops in excess of 900m <sup>2</sup> total floor area	<b>Patrons –</b>									
	Males	500	2400	1200	600	1200	1200	1000	4000	2000
	Females	300	600	1200	-	-	-	1000	4000	2000
6 – Restaurants cafes, bars, public halls, function rooms and 9a – out patients	<b>Patrons –</b>									
	Males	50	200	250	50	200	100	50	200	250
	Females	30	70	80	-	-	-	50	200	250
9a- Health-care buildings (Other than for out patients)	<b>Resident Patients –</b>									
	Males	-	16	8	-	-	-	16	32	16
	Females	-	16	8	-	-	-	16	32	16
- Other facilities – One shower for each 8, or part, patients or inmates.										
9b – Schools not being <i>early childhood centres</i>	<b>Staff and Employees</b>									
	Males	20	40	20	25	50	50	30	60	30
	Females	15	30	15	-	-	-	30	60	30
	<b>Students –</b>									
	Males	30	70	70	30	70	40	60	140	140
	Females	20	40	30	-	-	-	60	140	140
- Other facilities - A minimum of one shower each for male and female students										
9b – <i>Early childhood centres</i>	<b>Children</b>	-	30	15	-	-	-	-	30	15
- Other facilities - One shower must be provided.										

TABLE NF2.3 Continued SANITARY AND OTHER FACILITIES										
Class of Building	User	Max Number Served By -								
		Closet Fixture (s)			Urinal (s)			Washbasin (s)		
		1 Up to	2 Up to	Each Extra	1 Up to	2 Up to	Each Extra	1 Up to	2 Up to	Each Extra
9b – Sporting venues, theatres, cinemas, art galleries or the like and churches, chapels or the like	<b>Participants at sporting venues, theatres or the like</b>									
	Males	20	40	20	10	20	10	20	40	20
	Females	15	30	15	-	-	-	20	40	20
	Other facilities:	One shower for each 10 or part, participants								
	<b>Spectators or patrons</b>									
Males	250	500	500	100	200	100	250	500	500	
Females	75	250	250	-	-	-	250	500	500	

**NF2.4 Facilities for people with disabilities**

Sanitary facilities must be provided in accordance with table NF2.4 in every Class 3,5,6,7,8 and 9 building that is required by Part ND3 to be accessible to people with disabilities.

TABLE NF2.4 SANITARY FACILITIES FOR PEOPLE WITH DISABILITIES	
CLASS OF BUILDING	MINIMUM FACILITY FOR USE FOR PEOPLE WITH DISABILITIES
<p><b>Class 3</b> - In every <i>sole-occupancy unit</i> to which access for people with disabilities is <i>required</i> -</p> <p>(a) one closet pan and washbasin; and</p> <p>(b) one shower.</p>	
<p><b>Class 5,6,7 and 9</b> buildings with <i>floor area</i> more than 1000m<sup>2</sup> and</p> <p><b>Class 3</b> if accommodation is other than in <i>sole-occupancy units</i>, or other parts of the building are <i>required</i> to be accessible -</p> <p>NUMBER OF PERSONS FOR WHOM TOTAL FACILITIES NORMALLY REQUIRED</p> <p><b>Closet pans plus urinals -</b></p> <p>1 –100 .. .. .</p> <p>101 – 200 .. .. .</p> <p>More than 200 .. .. .</p>	<p>MINIMUM FOR USE BY PEOPLE WITH DISABILITIES</p> <p>(a) one unisex facility; or</p> <p>(b) one closet pan and washbasin for each sex.</p> <p>(a) 2 unisex facilities; or</p> <p>(b) one closet pan and washbasin for each sex and one unisex facility</p> <p>(a) 2 unisex facilities or one closet pan and washbasin for each sex and one unisex facility; and</p> <p>(b) one additional unisex facility or one closet pan and washbasin for each sex for each additional 100 persons.</p>
<p>In all cases, facilities for females must include adequate means for the disposal of sanitary towels.</p> <p><b>Bath or Showers</b> one shower or shower-bath for each 10 or part thereof normally required, but not less than one for use by both sexes.</p>	

---

**NF2.5 Construction of sanitary compartments**

- (a) Partitions – Other than in any *early childhood centre, sanitary compartments* must have doors and partitions must separate adjacent compartments and extend-
  - (i) from floor level to the ceiling in the case of a unisex facility; or
  - (ii) to a height of not less than 1500 mm above the floor if primary *school* children are the principal users, or 1800 mm above the floor in all other cases.
- (b) Facilities for people with disabilities – The construction and layout of *sanitary compartments* for use by people with

disabilities must comply with AS 1428.1, or NZS 4121 and NZS 4122.

**NF2.6 Interpretation: Urinals and washbasins**

- (a) A urinal may be either-
  - (i) an individual stall or wall hung urinal;
  - (ii) each 600mm length of a continuous urinal trough; or
  - (iii) a closet pan used in place of a urinal.
- (b) A wash basin may be either-
  - (i) an individual basin; or
  - (ii) a part of a hand wash trough served by a single water tap.

---

## ROOM SIZES

### NF3.1 Height of rooms

Minimum height below the ceiling and any framing excluding minor projections such as cornices, are:

- (a) Class 2, or 3 building, or Class 4 parts-
  - (i) *habitable* room – 2.4 m;
  - (ii) laundry or the like – 2.1 m; and
  - (iii) corridor or passageway – 2.1m.
- (b) Class 5,6,7 and 8 buildings-
  - (i) areas other than in (ii) – 2.4 m; and
  - (ii) corridor, passageway, or the like – 2.1 m.
- (c) Class 9a building –
  - (i) *ward* area – 2.4 m;
  - (ii) operating theatre or delivery room – 3.0 m; and
  - (iii) treatment room, clinic, eating room, passageway, corridor, or the like – 2.4 m.
- (d) Class 9b buildings-

- (i) *school* classroom or other *assembly building* or part that accommodates not more than 100 persons – 2.4 m; and
  - (ii) theatre, public hall or the *assembly building* or part that accommodates more than 100 persons – 3.0 m.
- (e) Ancillary and other spaces –
    - (i) bathroom, shower room, water closet, toilet room, airlock, tea preparation room, pantry, store room, garage, carparking area, or the like, in any class of building – 2.1 m.

### NF3.2 Reduced height permissible

These heights may be reduced if the reduction does not unduly interfere with the proper functioning of the room in-

- (a) attic rooms
- (b) rooms with a slopping ceiling or projection below ceiling line; or
- (c) other rooms or spaces.

### NF3.3 Ceiling fans

Ceiling fans and other such appliances must be at a minimum vertical clearance of 2.1 m.

---

---

## LIGHT AND VENTILATION

### NF4.1 Provision of Natural Light

Natural lighting must be provided in:

- (a) Class 2 buildings and Class 4 parts – to all *habitable rooms*.
- (b) Class 3 buildings – to all bedrooms and dormitories.
- (c) Class 9a building – to all rooms used for sleeping purpose.
- (d) Class 9b buildings – to all general purpose classrooms in primary or secondary *schools* and all playrooms or the like for the use of children in an *early childhood centre*.

### NF4.2 Methods and extent of natural lighting

Direct natural lighting must be provided by *windows* that-

- (a) have an aggregate light transmitting area measured excluding framing members, glazing bars or other obstructions of not less than 10% of the *floor area* of the room;
- (b) face-
  - (i) a court or other space open to the sky; or
  - (ii) an open verandah, open carport, or the like;
- (c) are not less than a horizontal distance from any adjoining allotment, or a wall of the same building or another building on the allotment that they face, that is the greater of-
  - (i) in a class 2,3 or 9 building or a class 4 part – 1 m;
  - (ii) in a *ward area* or other room used for sleeping purposes in a Class 9a building – 3 m; and
  - (iii) 50% of the square root of the height of the wall in which the *window* is located, measured in metres from its sill.

### NF4.3 Natural light borrowed from adjoining room

Natural lighting to a room in a Class 2 or 4 building, or in a *sole-occupancy* unit of a Class 3 building may come through a glazed panel or opening from an adjoining room (including an enclosed verandah) if-

- (a) in a Class 2 or 3 building or Class 4 part, both rooms are within the same *sole-occupancy* unit or the enclosed verandah is on common property;
- (b) the glazed panel or opening has an area of not less than 10% of the *floor area* of the room to which it provides light; and
- (c) the adjoining room has *windows* with an aggregate light transmitting area of not less than 10% of the combined *floor areas* of both rooms.

The areas specified in (b) and (c) may be reduced as appropriate if direct natural light is provided from another source.

### NF4.4 Artificial lighting

Artificial lighting must be provided-

- (a) in *required* stairways and ramps by means of separate electrical wiring circuits from the main switchboard for the exclusive use of the stairway or ramp; and
- (b) if natural lighting of a standard equivalent to that *required* by NF4.2 is not available and the periods of occupation, or use of the room or space will create undue hazard to occupants seeking egress in an emergency, in –
  - (i) Class 4 parts – to *sanitary compartments*, bathroom, shower rooms, airlock and laundries;
  - (ii) Class 2 buildings- to *sanitary compartments*, bathrooms, shower rooms, airlocks, laundries, common stairways and other spaces used in common by the occupants of the building; and
  - (iii) Class 3,5,6,7,8 and 9 building – to all rooms that are frequently occupied and all corridors, lobbies, internal stairways, other circulation spaces and paths of egress.

#### NF4.5 Ventilation of rooms

- (a) A *habitable room*, office, shop, factory, workroom, *sanitary compartment*, bathroom, shower room, laundry and any other room occupied by a person for any purpose must have adequate flow-through or cross-ventilation and air quality, including sufficient air-changes and fresh air quantities.
- (b) Provision of either –
- (i) natural ventilation complying with NF4.6; or
- (ii) a mechanical ventilation or air conditioning system complying with Table 3 of AS 1668.2, with provision for natural ventilation of NF4.6 for use in case of a lengthy failure of the mechanical system, satisfies (a).

Where the *required* ventilation relies on mechanical or air-conditioning systems, *habitable rooms*, offices, shops, factories, workrooms, or commercial laundries must have alternate natural ventilation for use in case of a lengthy failure of the mechanical system. The extent of natural ventilation available must be not less than 25% of the *required* under NF4.6. Otherwise the mechanical system must have a complete stand-by system including for power generation.

#### NF4.6 Natural ventilation

*Required* natural ventilation must be provided by permanent *windows*, openings, doors or other devices-

- (a) with an aggregate opening or openable size not less than 10% of the *floor area* of the room *required* to be ventilated; and
- (b) which open to-
- (i) a court, or space open to the sky; or
- (ii) an open verandah, open carport, or the like.

#### NF4.7 Ventilation borrowed from adjoining room

Natural ventilation to a room may come through a *window* opening, ventilating door or other device from an adjoining room (including an enclosed verandah) if

both rooms are within the same *sole-occupancy unit* or the enclosed verandah is common property, and-

- (a) in a Class 2 building, a *sole-occupancy unit* of a Class 3 building or a Class 4 part of a building-
- (i) the room to be ventilated is not a *sanitary compartment*;
- (ii) ventilation is not borrowed from one bedroom to another or between a bedroom and the kitchen;
- (iii) the *window*, opening, door or other device has a ventilating area of not less than 10% of the *floor area* of the room to be ventilated; and
- (iv) the adjoining room has a *window*, opening, door or other device with a ventilating area of not less than 10% of the combined *floor areas* of both rooms;
- (b) in a Class 5,6,7,8 or 9 building –
- (i) the *window*, opening, door or other device has a ventilating area of not less than 10% of the *floor area* of the room to be ventilated, measured not more than 3.6 m above the floor; and
- (ii) the adjoining room has a *window*, opening, door or other device with a ventilating area of not less than 10% of the combined *floor areas* of both rooms; and
- (c) the ventilating areas specified in (a) and (b) may be reduced as appropriate if direct natural ventilation is provided from another source.

#### NF4.8 Restriction on position of WCs and urinals

A room containing a closet pan or urinal must not open directly into-

- (a) a kitchen or pantry;
- (b) a public dining room or restaurant;
- (c) a dormitory in a Class 3 building;
- (d) a room used for public assembly; or
- (e) a workplace normally occupied by more than one person.



---

#### NF4.9 Airlocks

If a room containing a closet pan or urinal is prohibited under NF4.8 from opening directly to another room-

- (a) in a *sole-occupancy unit* in a Class 2 or 3 building or in a Class 4 part-
  - (i) access must be by an airlock, hallway or other room; or
  - (ii) the room containing the closet pan or urinal must be provided with an exhaust fan; and
- (b) in a Class 5,6,7,8 or 9 building (which is not an *early childhood centre*, *primary school* or *open spectator stand*) –
  - (i) access must be by an airlock, hallway or other room with a *floor area* of not less than 1.1 m<sup>2</sup> and fitted with *self-closing* doors at all access doorways; or
  - (ii) the room containing the closet pan or urinal must be provided with mechanical exhaust ventilation and the doorway to the room adequately screened from view.

#### NF4.10 Sub-floor ventilation

- (a) Suitable provision must be made to prevent undue deterioration of the lowest floor of a building because of dampness, other conditions on the allotment or the design of the building.
- (b) The following would satisfy the requirements of (a)-
  - (i) where timber is used, the floor framing must be suspended with an absolute minimum of 250 mm and an average minimum of 400 mm clearance from the ground underneath to the floor and the floor and the immediate surrounds of the building.

The average clearance must be determined as the average of the clearances at the corners of a 3 m square grid covering the building. Subfloor ventilation must be provided with ventilation openings totaling not less than 3% of the peripheral vertical area between the ground and the boundary of the floor. These openings are to be spaced uniformly and at not more than 1.8 apart.

- (ii) where other than timber is used;
  - subfloor ventilation must be provided if the floor is suspended;
  - an impervious cover provided over the ground surface beneath the building; or
  - the floor members suitably treated.

#### NF4.11 Public car parks

Every *storey* of a *public carpark* must have –

- (a) a mechanical ventilation or air-conditioning system complying with AS 1668.2; or
- (b) a suitable system of permanent natural ventilation in accordance with NF4.6.

#### NF4.12 Uncovered space for Class 4 parts

Class 4 parts of buildings must have sole access to a space open to the sky of 20 m<sup>2</sup> minimum area. Of this at least 5 m<sup>2</sup> must be at the same level as the Class 4 part and the rest may be at either 3 m above or 3 m below.

---

## WATERSUPPLY PLUMBING

### NF5.1 General requirements

The plumbing work for water supply must ensure-

- (a) the appropriateness of the materials and products used;
- (b) the correct sizing of water services for the intended use;
- (c) the control of cross-connections and prevention of backflow;
- (d) adequate care in the installation of the services;
- (e) suitable provision of main and subsidiary storage as *required*;
- (f) adequate connections to sanitary services without endangering health and hygiene; and
- (g) the installation of hot water system to provide safe and adequate service.

### NF5.2 Means of compliance

The requirements of NF5.1 are satisfied if all plumbing for watersupply is carried out to the relevant provision of-

- (a) AS 3500 – Part 1 for cold water service; and
- (b) AS 3500 – Part 4 for hot water service.

### NF5.3 Pipe which are not easy to access

Particular attention is drawn to the provisions in AS 3500 – Parts 1 and 4 which prohibit the installation of pipes and fittings of certain materials in locations which are concealed or difficult to access. These include pipe made of ABS, galvanised steel, polybutylene and UPVC. Pipes and fittings made of copper, copper alloy, stainless steel, ductile iron, cast iron and polyethylene when used in concealed or difficult to access locations must follow the special precautions specified in AS 3500 – Parts 1 and 4.

### NF5.4 Access to domestic-type water heaters.

- (a) A household water heater which is installed in a building must-
  - (i) be supported on construction sufficient to carry its full capacity weight and any possible wind or earthquake loads;
  - (ii) be positioned to enable adequate access for operation, maintenance and removal; and
  - (iii) provide suitably for any overflow, especially if installed in a concealed location.
- (b) AS 3500 – Part 4 is the relevant standard for the installation of a household water heater.

---

## SANITARY PLUMBING AND DRAINAGE

### NF6.1 General requirements

Sanitary plumbing and drainage must ensure-

- (a) the appropriateness of the products and materials used;
- (b) the correct sizing of drainage services for the intended use;
- (c) adequate care in the installation of the services including the provision of appropriate grades; and
- (d) that foul gases are not allowed to produce unhygienic conditions or any nuisance to anyone.

#### NF6.1.1 Specific requirements

Sanitation facilities must ensure-

- (f) no discharge of wastewater of any kind to surface water;
- (g) no discharge to a soil surface that is less than 2.5 metres above maximum groundwater level;
- (h) the maximum design loading to a soil surface shall not exceed:
  - 35mm per day for septic tank effluent.
  - 70mm per day for secondary or better treated effluent.
- (i) the effluent distribution system shall achieve a uniform application at or less than the maximum design loading rate.
- (j) system chosen is consistent with Figure NF6.1

### NF6.2 Means of compliances

The requirements of NF6.1 are satisfied if all sanitary plumbing and drainage works are carried out to the relevant provisions of AS 3500 – Part 2 – Sanitary plumbing and sanitary drainage.

### NF6.3 Certain floors to be drained

In a Class 2, 3 or 4 Part building the floor of each bathroom and laundry in a *sole-occupancy unit* which is located at other than the lowest level must be graded to permit drainage to a floor waste gully.

### NF6.4 Grease trap

Where the nature of the occupancy is such that the wastewater contains grease, fats or oils to levels unacceptable to the Authority having jurisdiction, a suitable grease trap must be installed. The accumulated grease and oils must be removed at intervals sufficient to prevent their escape into the disposal system. After removal the grease and oils must be suitably disposed off.

### NF6.5 Commercial , Institutional and Large Scale Residential

The method, design and construction of the treatment plants and disposal facilities for Commercial Institutional and large scale residential developments shall be certified by an *approved person* and shall include disposal of effluent by means of irrigation onto land where sufficient land is available.

#### NF6.5.1 Performance Standards

Effluent from sewage treatment plants referred to NF6.5 shall conform with the following performance standards:

- Five Day Biochemical Oxygen Demand (BOD<sub>5</sub>) shall not exceed 100mg/l (one monthly measurement annual means not to exceed).
- Suspended Solids (SS) shall not exceed 100Mg/l (one monthly measurement annual means not to exceed)
- Faecal Coliforms (FC) shall be less than 10,000 MPN/100ml for 95% of the time. (Based on monthly measurements taken over an annual period).

#### NF6.5.2 Prohibitions

The following practices shall be prohibited:

- Direct discharge of treated effluent to marine waters.
- Treated effluent shall not be discharged into open pits or trenches.

### NF6.6 Resorts and Hospitals

The method, design and construction of the treatment plants and disposal facilities for Resort developments and hospitals shall be certified by an *approved engineer* and shall include disposal of effluent by

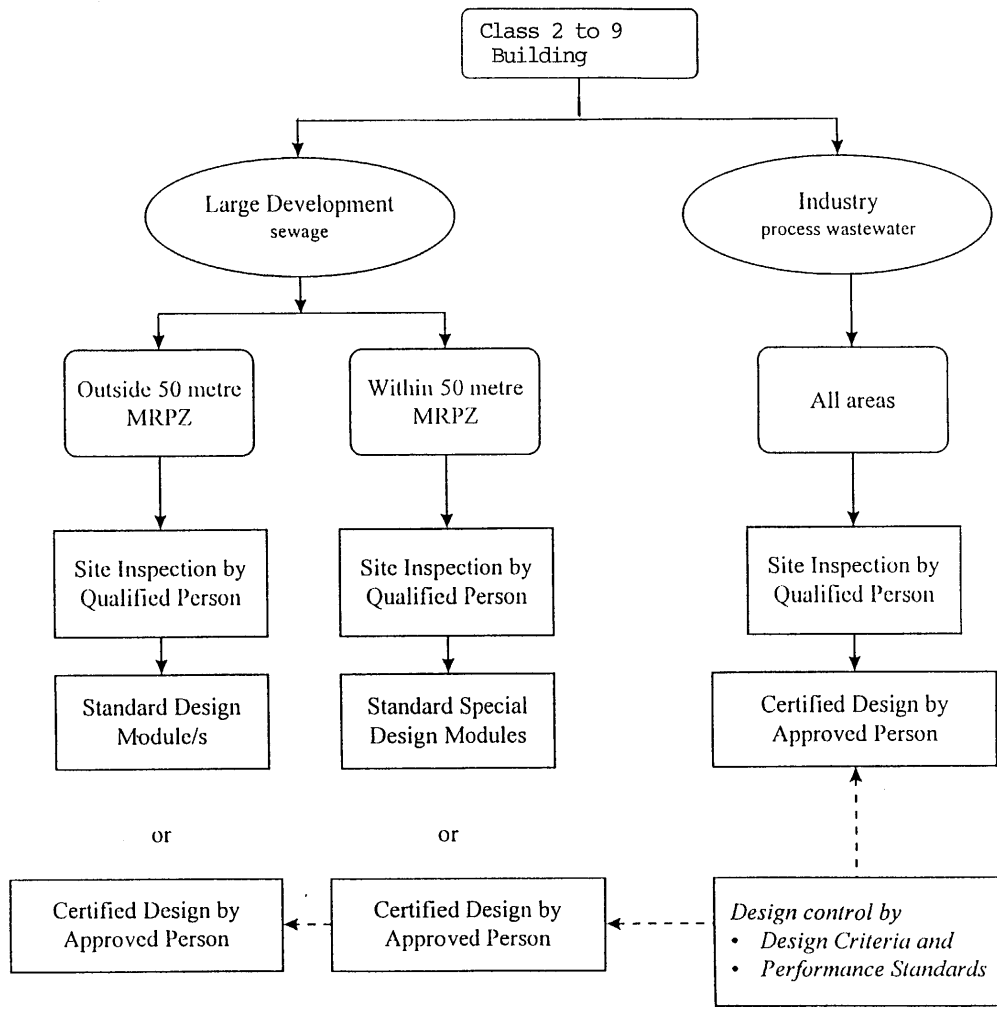

MPRZ = Marine and River Protection Zone

FIG. NF 6.1 DECISION MATRIX

---

means of irrigation onto land where sufficient land is available.

#### **NF6.6.1 Performance Standards**

Effluent from sewage treatment plants referred to NF6.6 shall conform with the following performance standards:

- Five Day Biochemical Oxygen Demand (BOD<sub>5</sub>) shall not exceed 300mg/l (one monthly measurement annual means not to exceed).
- Suspended Solids (SS) shall not exceed 30Mg/l (one monthly measurement annual means not to exceed)
- Faecal Coliforms (FC) shall be less than 5,000 MPN/100ml for 95% of the time. (Based on monthly measurements taken over an annual period).

#### **NF6.6.2 Prohibitions**

The following practices shall be prohibited:

- Direct discharge of treated effluent to marine waters.
- Treated effluent shall not be discharged into open pits or trenches.

#### **NF6.7 Industrial Sewage and Wastewater Disposal**

All developments shall comply as a minimum with the Approved Treatment and Disposal methods

Performance Criteria and Prohibitions as specified for Commercial, institutional and Large Scale Residential Buildings in Clause NF6.5.

In addition to these criteria the following is required:

- the industrial site shall be inspected by a *qualified person*;
- a certified design for the disposal of industrial waste shall be prepared by an approved person;
- there shall be no discharge of industrial wastewater effluent, treated or untreated direct to ground if any adverse environmental effect may occur from such a discharge or if there is uncertainty whether such an adverse environmental effect may or may not occur;
- performance standards for sewage effluent from resorts and hospitals shall be met;
- implementation of the certified design shall be inspected and approved in writing by a *qualified person* during and on completion of construction.

#### **NF6.8 Small treatment plants**

The details given in Annexure 2 to Specification DF2.1 may be used for the preliminary design of the main elements of a septic tank system if such a system is considered.

---

## ROOF DRAINAGE

### NF7.1 General requirements

Gutters and downpipes where provided must have sufficient capacity to reasonably prevent the overflow of rain water into the building. The peak intensities of rainfall that the gutters and associated downpipes must be able to handle are as follows;

- (a) Eaves gutters –  
the 20 year return intensity
- (b) Box and valley gutters-  
the 100 year return intensity
- (c) Gutters and downpipes for temporary  
building –

the 5 year return intensity of rainfall.

Eaves gutters other than for temporary buildings must have a designed free-board of 25 mm and box gutters, 35 mm.

### NF7.2 Means of compliance

The requirements of NF7.1 are satisfied if the requirements of AS/NZS 2179 – Metal rainwater goods – Specification and AS 2180 – Metal rain water goods – Selection and installation are met. Specification NF7.2 covers some of these requirements.

---

## SIZING OF GUTTERS AND DOWNPIPES

### 1 DESIGN CRITERIA

The design of a roof-drainage system is based on the following factors:

- Rainfall intensity and risk of flooding
- Catchment area of roof
- Gutter efficiency
- Spacing of downpipes.

#### 1.1 Rainfall Intensity

In rainstorm long periods of steady rainfall are interspersed with peak intensities for short periods. The roof-drainage system must be capable of handling the peak intensities without flooding or overflow.

The 5 year return intensity is used in the design of temporary structures of short life. The design of eaves gutters of permanent buildings must be based on the 20 year return intensity and of internal box gutters and valley gutters on the 100 year return intensity. The values of these intensities for representative areas in the country may be ascertained from the Meteorological Department. A freeboard of 25 mm for eaves gutters and of 35 mm for internal box gutters and valley gutters are *required* to provide against overflow into buildings.

### 2. CATCHMENT

A roof drainage system is best analysed by dividing it into lengths of gutter each sloping down from a high point to an outlet with a downpipe. A long length of roof usually drains into several lengths of gutter separated by expansion joints that are also high points. The catchment area for a length of gutter is determined by multiplying the rafter length by the length of gutter (G) and adding a proportion of any vertical surface against which rain can be driven. A reasonable procedure is to add half the area of a very exposed vertical surface and smaller proportions for less extreme conditions (see Figure 2.1)

The length G of a gutter is measured as the distance from a high point in the gutter to the downpipe when the down-pipe is at the end of the gutter and between high points when the downpipe is not at the end (see Figure 2.2)

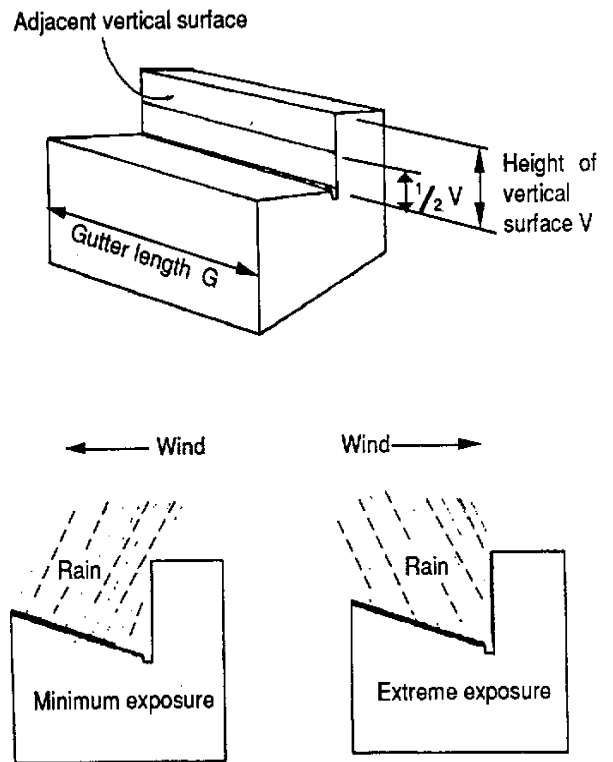

FIGURE 2.1 EFFECT OF VERTICAL SURFACE ON CATCHMENT

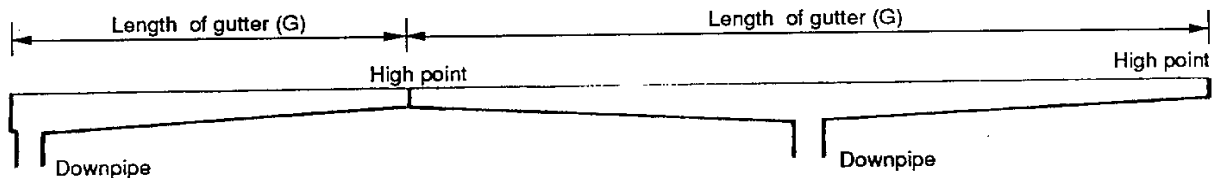

FIGURE 2.2 MEASURING GUTTER LENGTH

### 3 EAVES GUTTER

The procedure for the design of eaves gutters is as follows:

#### 3.1 Size

Space the downpipes suitably and calculate the catchment area per downpipe. For eaves gutters of permanent buildings determine the gutter discharge area by matching the catchment area against the applicable intensity line in Figure 3.1. Interpolation is allowed. If the gutter discharge area obtained is more than what is available from a standard gutter after allowing for a 25 mm freeboard, either reduce the spacing of the downpipes and recalculate or proceed specify a specially fabricated gutter. With rectangular fabricated gutters an additional allowance of 10 percent of area must be made in addition to the freeboard allowance.

The net cross-sectional area of each vertical downpipe, including the nozzle must be not less than 50 per cent of the gutter discharge area.

#### 3.2 Slope

The fall of an eaves gutter must never be less than 1 in 500 but in areas where dust or debris is likely to build up between rain periods the slope must be as steep as 1 in 50.

#### 3.3 Leaf guards and overflows

Leaf guards must be fitted to prevent the nozzle to the downpipe from becoming blocked wherever leaves or other debris are likely to collect in the gutter. If the eaves gutter has a fascia front higher than the rear lip, an overflow must be fitted at a level below that the lowest point in the rear lip.

#### 3.4 Proportion

The proportions of a rectangular eaves gutter are ideal when its width is twice the maximum depth of water flowing in it. Although a narrow deep gutter will provide a greater head of water over the outlet with a consequent improvement in the discharge capacity of the outlet, a shallower gutter is usually easier to maintain.

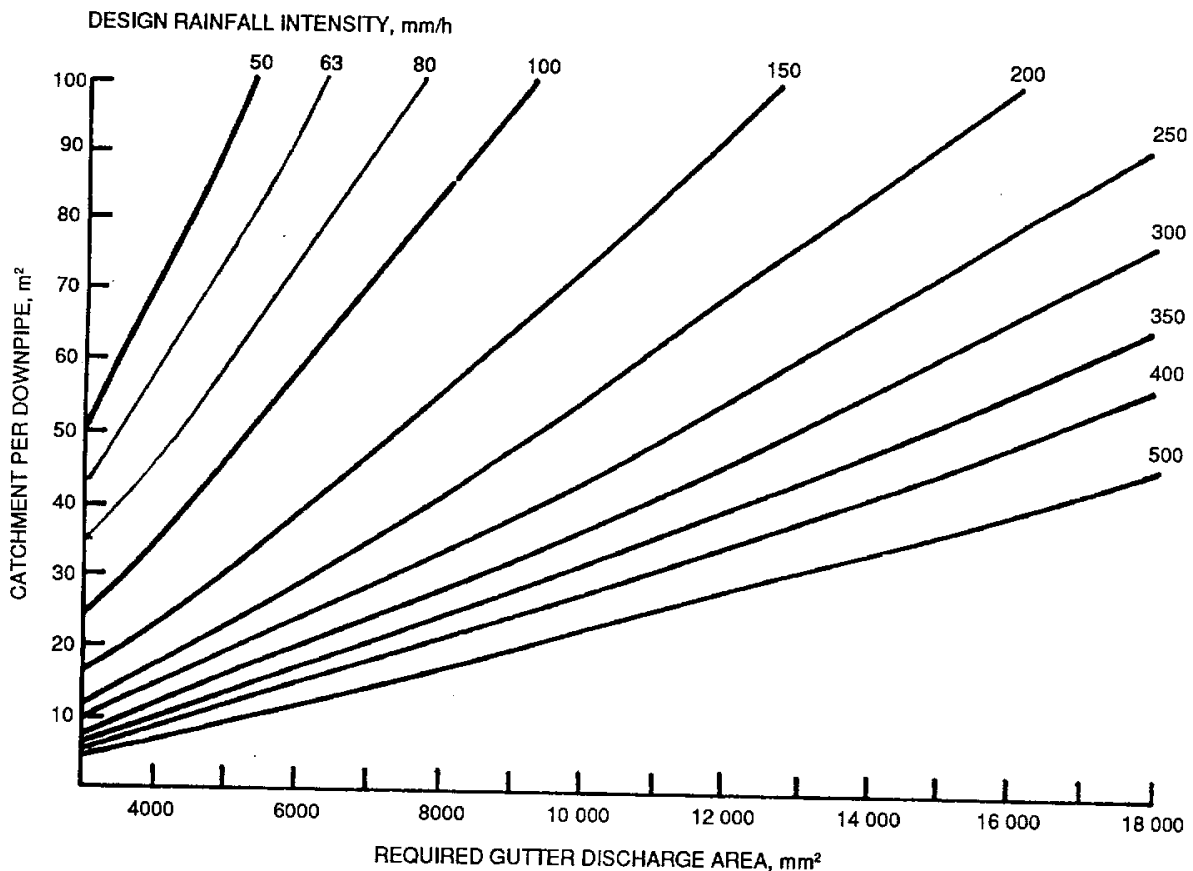

FIGURE 3.1 EAVES GUTTER SIZING



#### 4 INTERNATIONAL BOX GUTTER

The procedure for the design of box gutters is as follows:

Ideally, box gutters must be straight, at least 300 mm wide, capable of supporting a workman, fixed at a slope of not less than 1 in 200, and provided with an overflow and adequate downpipe outlets not more than 18 m apart. The gutters must have sufficient slope to clear dust and debris and they might need leaf guards.

#### 4.1 Size of gutter

Space the downpipe suitably and calculate the catchment area per downpipe. From Figure 4.1 using the calculated catchment area and the applicable rain intensity, determine the design flow for the gutter and the downpipe. Select a width of not less than 300 mm for the box gutter. The required depth can then be read from Figure 4.1.2 by using the selected width and design flow. The depth allows for a freeboard of 35 mm which will be necessary during cyclonic wind along with normal turbulence and ripples. The depth thus determined assumes that the gutter is laid to zero slope. To adjust for the slope, use the depth determined from Figure 4.1.2 in Figure 4.1.3 and read off the depth adjusted for slope against the appropriate slope line. The minimum depth must be 80 mm.

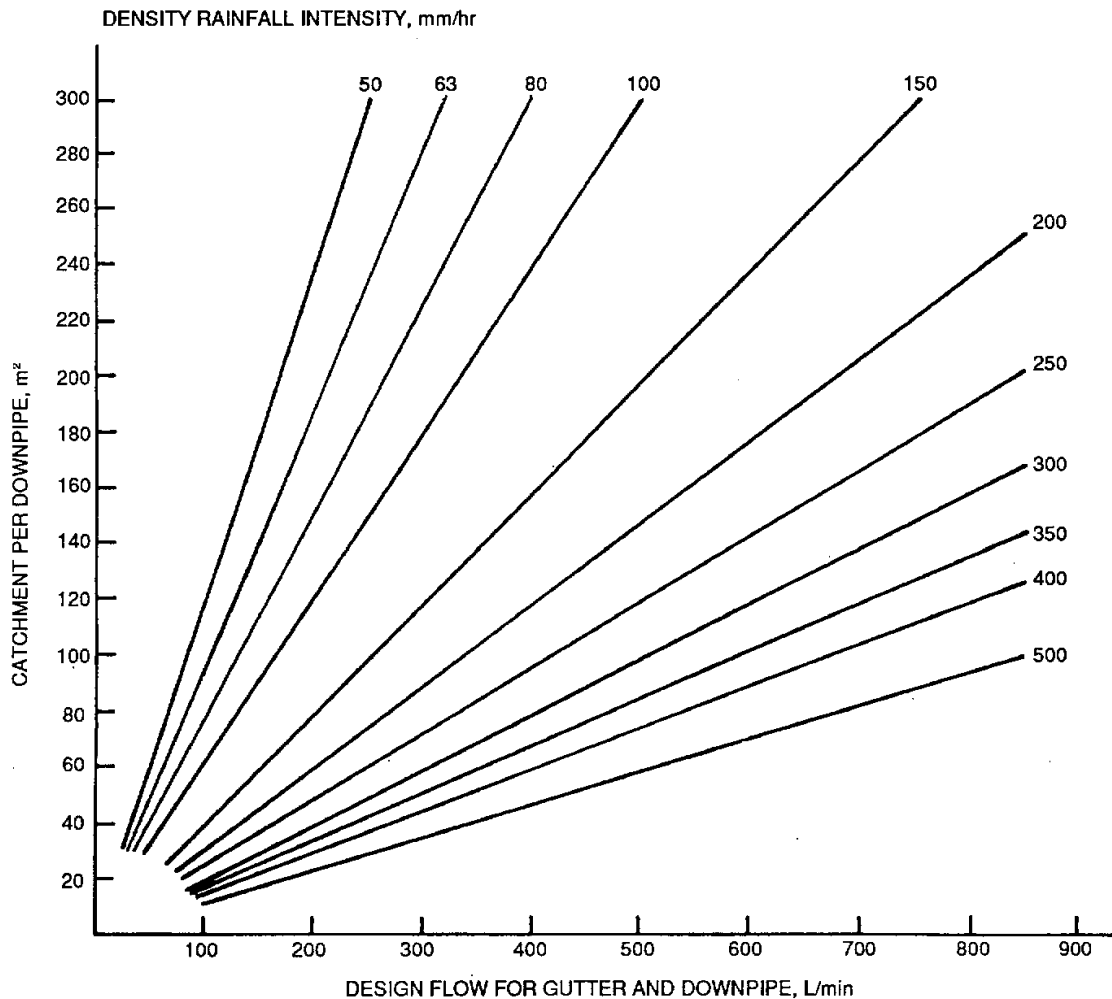
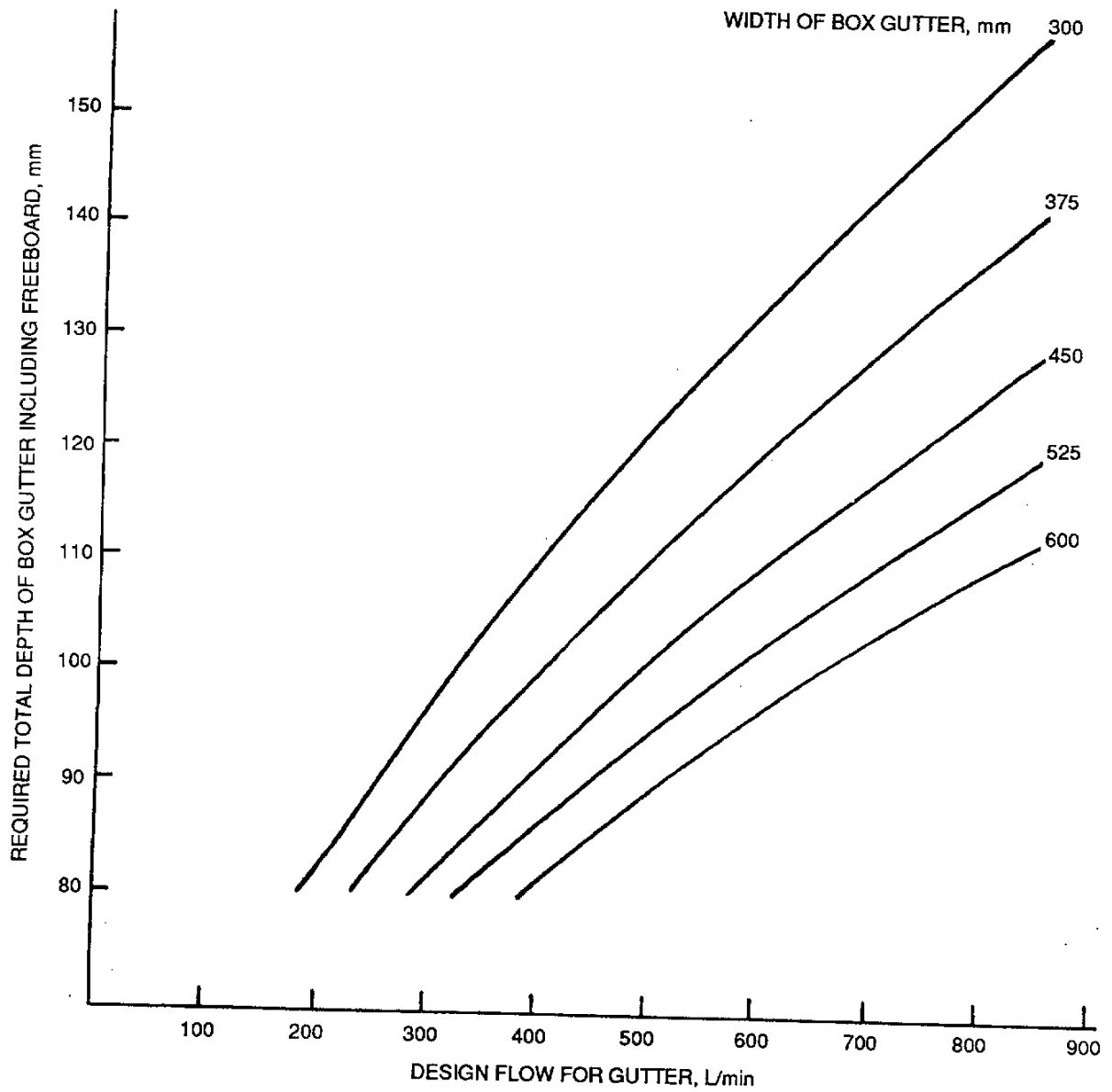

FIGURE 4.1.1 INTERNAL BOX GUTTER DESIGN FLOW



Notes:

- 1 Graph assumes zero slope. To take advantage of slope, see Fig. 4.1.3.
- 2 Graph assumes 35 mm freeboard.

FIGURE 4.1.2 REQUIRED DEPTH OF BOX GUTTER FOR DESIGN FLOW

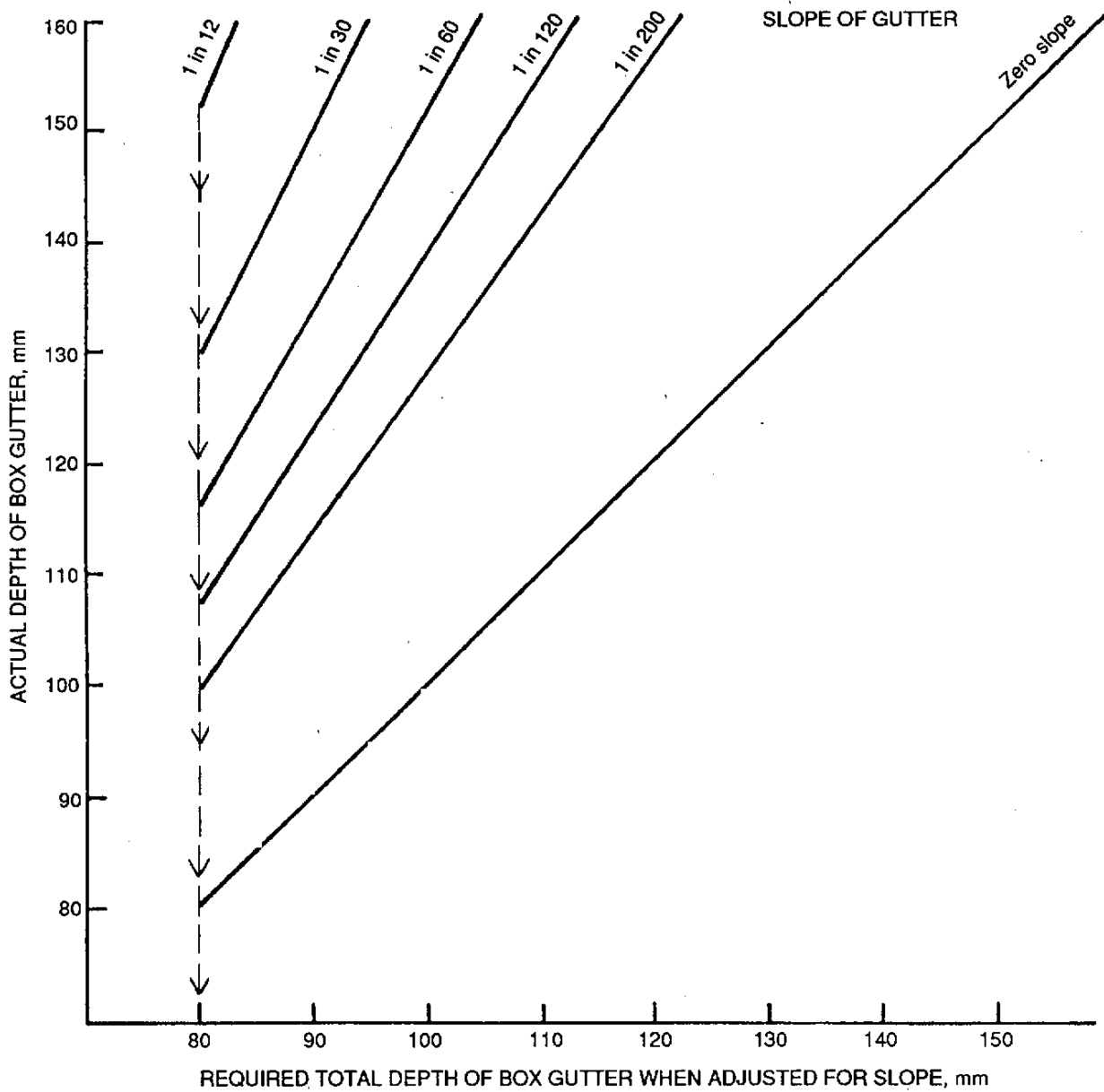

FIGURE 4.1.3 BOX GUTTER DEPTH - ADJUSTED FOR SLOPE

## 4.2 Size of downpipes

The size of the downpipe can be determined from figure 4.2 by reading against the design flow and the actual depth of the gutter determined from using figure 4.1.3. The downpipes can be round or rectangular.

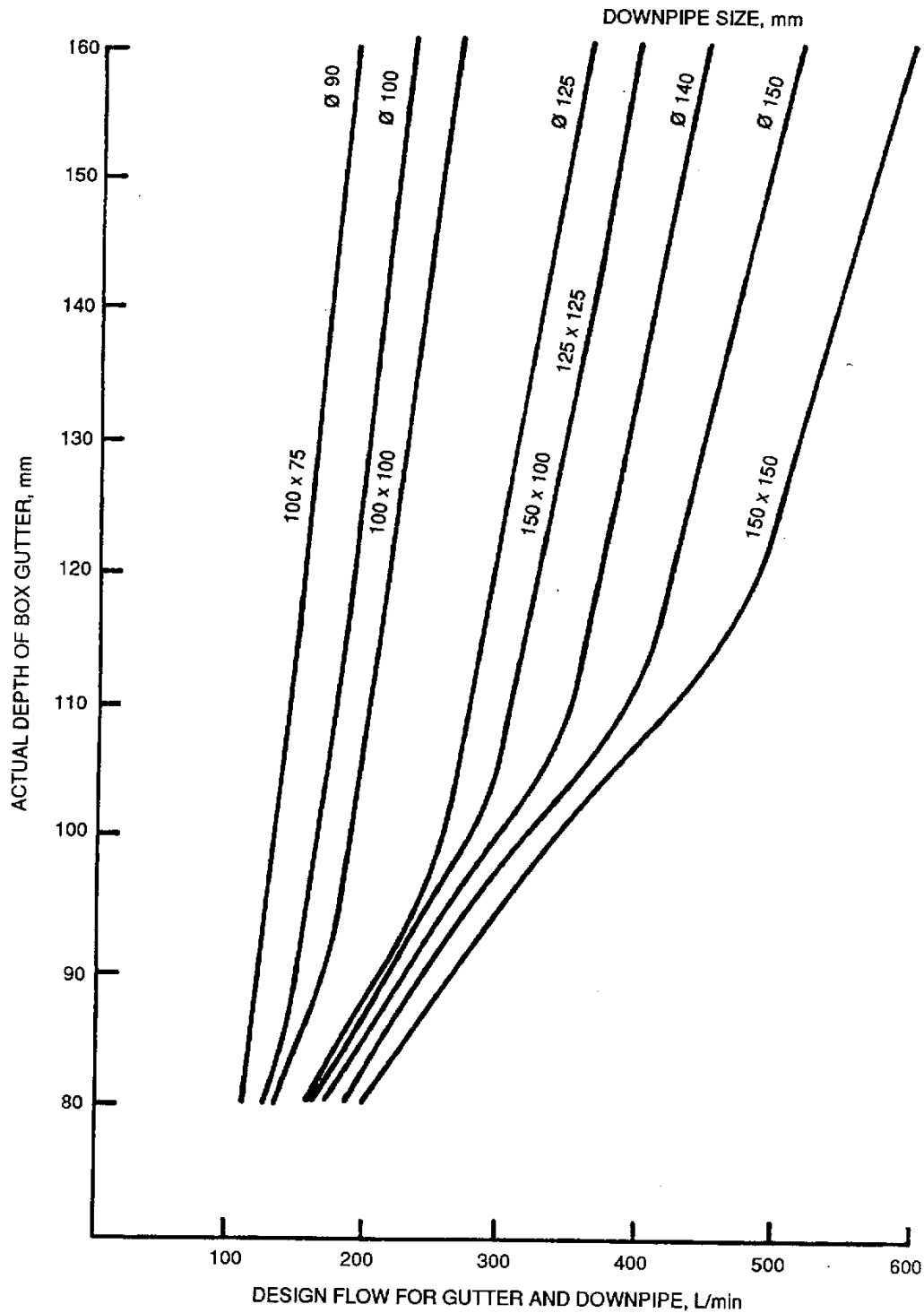

FIGURE 4.2 REQUIRED SIZE OF DOWNPIPE FOR BOX GUTTER  
(RAINHEAD AND SUMP NOT CONSIDERED)

### 4.3 Overflow

A box gutter discharging into a downpipe must have an overflow outlet to allow for blockage and to provide for rainfall intensities greater than those used for design. To cope only with peaks in rainfall it is sufficient for the overflow outlet to have a cross sectional area equal to 15 percent of the total cross-sectional area of the gutter, that is an overflow area of  $0.15 dw$  (see Figure 4.3.1).

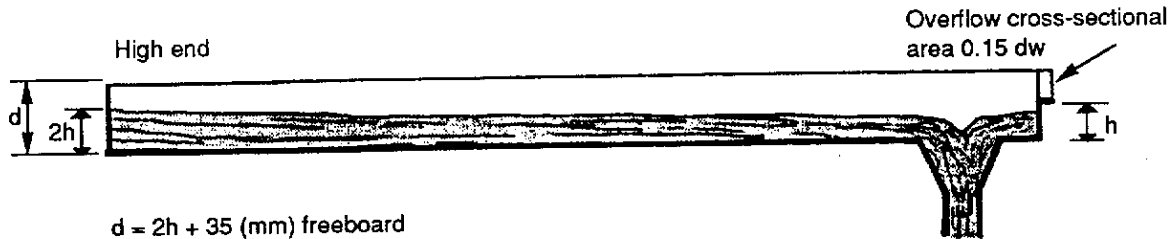

FIGURE 4.3.1 OVERFLOW OUTLET

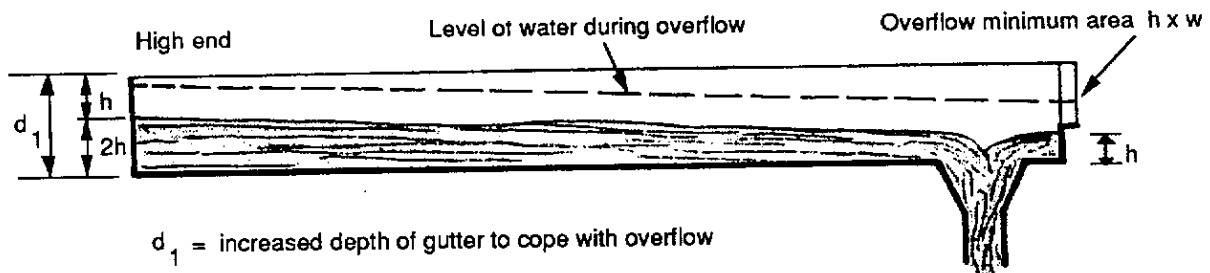

FIGURE 4.3.2 OVERFLOW WITH BLOCKED DOWNPIPE

But if the overflow is intended to cope with the effect of a total blockage of the downpipe during a peak period then the cross-sectional area of the overflow outlet must equal the cross sectional area of the water flow at the outlet of the gutter ( $h \times w$  for minimum fall). The overflow should be slightly above level  $h$  and if it is the same width as the gutter, the depth of the gutter will have to be further increased by an amount equal to  $h$  to accommodate the flow of water in a crisis (see Figure 4.3.2). The slope factor must not be taken into account when determining the new depth for the gutter and the amount of freeboard added to the increased gutter depth will depend on the risk the designer wishes to take regarding the possibilities of failure of the roof drainage system during a peak period. Other methods of preventing overflow due to blocked downpipes are the provision of rainheads and sumps.

---

## RAINHEADS AND SUMPS

### 4.4 Rainheads

The rainhead is a device used to increase the capacity of a downpipe at the end of a box gutter and to allow for overflow in case of a blocked downpipe. The discharge capacity of an outlet increases with the depth of water (head) over the outlet. The rainhead is located at the far end of a gutter and consists of a sump and overflow arrangements. The sump increases the flow through the downpipe by providing an additional head of water. The overflow provides safety against water spilling into the building if the downpipe is blocked. The detailed design of rainheads is given in AS 2180.

### 4.5 Sumps

Where a sump is fitted to the sole of a gutter it provides a local reservoir and the additional head increases the flow through the downpipe. The detailed design of sumps is given in AS 2180.

## 5 DOWNPIPES

### 5.1 Location

Downpipes must be located externally, but where it is necessary to locate a downpipe internally the pipe must be accessible so that any blockage can be cleared. Access for cleaning must be provided at the base of all downpipes that are connected directly to a storm water drain. Downpipes are most efficient when located at the centre of a length of gutter.

### 5.2 Swirl

The performance of an outlet with the head of water more than 1/3 of its diameter will be reduced if swirl occurs at the outlet. This would generally happen only where rainheads or sump are included in the system. Swirl can be eliminated if the centerline of the downpipe is kept no more than a distance equal to its diameter or the average of its cross-sectional dimensions, away from the nearest vertical side of the rainhead or the sump.

### 5.3 Gratings

Where a grating or strainer is fitted to a rain-water outlet the total area of the perforations in the grating must have at least 1.5 times the cross-sectional area of the outlet. Strainer gratings must project above the

calculated level of low at the outlet and must be cleared of accumulated debris regularly.

## 6 INCOMPATIBLE MATERIALS

Dissimilar metals must be separated by a non-conducting gasket or similar device to prevent electro-chemical corrosion. Water draining from copper components must not discharge onto non-copper components for the same reason. However, water can be safely drain from non-copper onto copper components. (The prevention of electro-chemical corrosion between metals will not necessarily prevent atmospheric corrosion of the individual metals).

## 7 EXPANSION JOINTS FOR GUTTERS

Metal gutters must be provided with expansion joints to prevent distortion and resulting damage and reduced flow. The maximum length between expansion joints is given in Table 8.

Material	Estimated exposed temperature range (°C)	Distance between 20mm expansion joints (m)
Aluminum	45	18
Copper	55	21
Stainless Steel	40	30
Steel	50	33
Zinc	50	15

## 8 STORMWATER

**9.1** Where a downpipe discharges into a storm water gully it must terminate below the gully grating, and where the connection is made directly to a stormwater pipe underground the internal diameter of the underground pipe must be greater than that of the downpipe. Underground stormwater pipes draining roof and paved catchments must be laid in straight lines at uniform gradients between sumps or collection pits. Large paved areas and roadways must slope towards drainage points with a minimum cross-fall of 1 in 60 for bitumen or concrete surfaces and 1 in 120 for concrete kerb channels.

### 8.2 Pipe sizes

Table 9.2 indicates the maximum total catchment area of roof and paving that can be drained by underground pipe laid at different gradients, of various diameters and running half full. Areas shown above the heavy line will have a flow velocity insufficient to flush out debris.

The table is for a rainfall intensity of 115 mm/h. For other rainfall intensities, the horizontal area to be drained must be proportionally adjusted by multiplying the area by 115 and dividing by the required rainfall intensity. The proportionally adjusted area can be used in the Table to determine the pipe size.

<b>TABLE 9.2 STORMWATER DRAIN SIZES TO TAKE FLOW FROM DOWNPIPES AND PAVEMENTS</b>				
Diameter of Pipe (mm)	Maximum horizontal projected areas (m <sup>2</sup> ) that can be drained at various gradients when the rainfall intensity is 115 mm/h			
	1 in 50	1 in 100	1 in 150	1 in 200
100	220	150	130	110
150	600	430	350	260
200	1300	950	780	650
250	2350	1650	1300	1130
300	3700	2600	2170	1910
375	6700	4700	3820	3130
450	8800	6950	5650	4800

---

NATIONAL  
BUILDING  
CODE  
2000

PUBLIC BUILDINGS AND GROUP DWELLINGS (CLASS 2 TO 9)

SECTION **NG**

---

ANCILLARY PROVISIONS

---

Performance Requirements  
Deemed-to-Satisfy Provisions

- NG1 Minor Structures and Components
  - NG2 Fireplaces, Chimneys and Flues
  - NG3 Atrium Construction
-



---

## CONTENTS

### PERFORMANCE REQUIREMENTS

### DEEMED-TO-SATISFY PROVISIONS

Part		Part	
NG1	Minor Structures and Components	NG1.6	Fences
NG1.1	Swimming pools	NG2	Fireplace, Chimneys and Flues
NG1.2	Refrigerated chambers, strong rooms and vaults	NG2.1	General requirements
NG1.3	Parapets on flat roofs	NG2.2	Open fireplaces
NG1.4	Projections over public places	NG2.3	Incinerator rooms
NG1.5	Movable awnings or sunshades over public places.	NG3	Atrium Construction

---

---

## PERFORMANCE REQUIREMENTS

### OBJECTIVES AND REQUIRED PERFORMANCE

This Section contains more specific requirements for particular parts of buildings or structures.

Parts of buildings and structures must be so designed and constructed that the following objective, in addition to those listed for Sections B, NC, ND, NE and NF where relevant, are fulfilled:

#### NGP1 Minor Structures and Components

##### NGP1.1 Swimming pools-

- (a) Suitable means for the disposal of waste and drainage must be provided to a *swimming pool*.
- (b) Access by unsupervised young children to *swimming pools* must be restricted.

##### NGP1.2 Refrigerated chambers, strong rooms and vaults-

Refrigerated or cooling chambers, strong rooms and vaults, or the like, which are capable of entry by a person must have adequate safety measures to facilitate escape and for alerting persons outside the chamber or vault in the event of an emergency.

##### NGP1.3 Safety at elevated places

Elevated places with regular access such as some flat roofs must have adequate protection to prevent anyone from falling.

##### NGP1.4 Use of the air space over public places

Any use of the air space over public places such as footpaths and roads must be limited to ensure that normal public use of such places is not obstructed.

##### NGP1.5 Aesthetics

Any minor structure such as fencing, awnings and such like must be suited to the general surroundings and the occupancy of the buildings and the neighborhood.

#### NGP2 Fireplaces, Chimneys and Flues

Fireplaces, chimneys and flues must be adequately constructed or separated to prevent-

- (a) ignition of nearby parts of the building; or
- (b) escape or discharge of smoke to the inside of the building or to adjacent *windows*, ventilation inlets, or the like.

#### NGP3 Atrium Construction

The construction of an *atrium* must not unduly increase the danger to occupants from fire or smoke.

---

## DEEMED-TO-SATISFY PROVISION

### MINOR STRUCTURES AND COMPONENTS

#### NG1.1 Swimming pools

- (a) Drainage: A *swimming pool* must have suitable means of drainage.
- (b) Safety fencing: A *swimming pool* with a depth of water more than 300 mm must have suitable barriers or safety fencing in accordance with AS 2818 and AS 1926 to restrict access by young children to the immediate pool surrounds if the *swimming pool* is associated with a Class 2 or 3 building or is a public pool.

#### NG1.2 Refrigerated chambers, strong rooms and vaults

- (a) A refrigerated or cooling chamber which is of sufficient size for a person to enter must-
  - (i) have a door which is in an opening with a clear width of not less than 600 mm and a clear height of not less than 1.5 m; and
  - (ii) at all times, be able to be opened from inside without a key.
- (b) A strong room or a vault in a building must have –
  - (i) internal lighting controllable only from within the room; and
  - (ii) a pilot light located outside the room but controllable only by the switch for the internal lighting.
- (c) A refrigerated or cooling chamber, strong room or vault must have a suitable alarm device located outside but controllable only from within the chamber, room or vault.

#### NG1.3 Parapets on flat roofs

Where a flat roof or other elevated place has regular access a parapet or balustrade of not less than 1 m height above the surface of the roof or elevated place must be provided. The width of any opening in the parapet or balustrade must not exceed 100 mm.

#### NG1.4 Projections over public places

Buildings must not project beyond the allotment boundary. Architectural features such as eaves cornices clocks lamps ventilating equipment trade signs hoardings flag poles bay or oriel windows and such like as well as a platform or balcony to provide additional means of egress from an exiting building, may however project over public footpaths or roads with the following minimum clearances-

- (a) 3300 mm above existing or intended finish level of footpaths; and
- (b) the outer extremity of the feature must be set back 300 mm from the existing or intended kerb.

Any drainage from such architectural features (including drainage from air-conditioning and other ventilating equipment) must be suitably taken down to a drain with downpipes which must also satisfy the *required* clearances.

#### NG1.5 Moveable awnings or sunshades over public places

Any movable awnings or sunshades must be firmly fixed so that they do not create any danger obstruction or inconvenience to pedestrians. They must provide the following minimum clearances if they project over public places:-

- (a) 2300 mm above the finished levels of the footpath; and
- (b) their outer extremity must be set back 300 mm from the kerb.

#### NG1.6 Fences

Any fencing or free-standing wall must be suited to the occupancy of the building within. It must not detract from the general aesthetic appearance of the surroundings. If any barbed wire or other such is used it must be at a height of not less than 2 m above the finished level of any existing or intended adjacent footpath.

## FIREPLACES, CHIMNEYS AND FLUES

### NG2.1 General Requirements

A chimney or flue must be constructed-

- (a) to withstand the temperatures likely to be generated by the appliance to which it is connected;
- (b) so that the temperature of the exposed faces will not exceed a level that would cause damage to nearby parts of the building;
- (c) so that hot products of combustion will not-
  - (i) escape through the walls of the chimney or flue; or
  - (ii) discharge in a position that will cause fire to spread to nearby *combustible* materials or allow smoke to penetrate through nearby *windows*, ventilation inlets, or the like;
- (d) in such a manner as to prevent rainwater penetrating to any part of the interior of the building;
- (e) such that its termination is not less than:
  - (i) 600 mm above any point of penetration of or contact with the roof; and
  - (ii) 900 mm above any opening or openable part in any building, within 3 m horizontal distance of the chimney or flue; and
- (f) so that it is accessibly for cleaning.

### NG2.2 Open fireplaces

An open fireplace, or solid-fuel burning appliance in which the fuel-burning compartment is not enclosed, satisfies NG2.1 if it has-

- (a) a hearth constructed of stone, concrete, masonry or similar *non-combustible* material so that –
  - (i) it extends not less than 300 mm beyond the front of the fireplace opening and not less than 150 mm beyond each side of that opening;
  - (ii) it extends beyond the limits of the fireplace or appliance not less than

300 mm if the fireplace is free-standing from any wall of the room;

- (iii) its upper surface does not slope away from the grate or appliance; and
- (iv) *combustible* material situated below the hearth (but not below that part *required* to extend beyond the fireplace opening or the limits of the fireplace) is not less than 155 mm from the upper surface of the hearth;
- (b) walls forming the sides and back of the fireplace up to not less than 300 mm above the underside of the arch or lintel which-
  - (i) are constructed in 2 separate leaves of solid masonry not less than 180 mm thick, excluding any cavity; and
  - (ii) do not consist of concrete block masonry in the construction of the inner leaf;
- (c) walls of the chimney above the level referred to in (b)-
  - (i) constructed of masonry units with a net volume, excluding cored and similar holes, not less than 75% of their gross volume, measured on the overall rectangular shape of the units, and with an actual thickness of not less than 90 mm; and
  - (ii) lined internally to a thickness of not less than 12 mm with rendering consisting of 1 part cement, 3 parts lime, and 10 parts sands by volume, or other suitable material; and

- (d) suitable damp-proof courses or flashing to maintain weatherproofing.

### NG2.3 Incinerator rooms

- (a) If an incinerator is installed in a building any hopper giving access to a charging chute must be-
  - (I) *non-combustible*;
  - (II) gastight when closed;

- 
- (III) designed to automatically return to the closed position after use;
  - (IV) not attached to a chute that connects directly to a flue unless the hopper is located in the open air; and
  - (V) not located in a *required* exit.
- (b) If an incinerator is in a separate room, that room must be separated from other parts of the building by construction with a FRL of not less than 60/60/60.
-

---

## ARTRIUM CONSTRUCTION

NG3.1 The design of any *atrium* along with the attendant life safety provisions such as fire prevention, fire fighting, smoke exhaust systems, etc. must fulfil up-to-date and relevant fire engineering principles and practices.

---

---

NATIONAL  
BUILDING  
CODE  
2000

**PUBLIC BUILDINGS**

SECTION **NH**

---

**SPECIAL USE BUILDINGS**

**Performance Requirements  
Deemed-to-Satisfy Provisions**

**NH1 Theatres, Stages and Public Halls**

---

# CONTENTS

## OBJECTIVES

## PERFORMANCE REQUIREMENTS

Part

**NH1 Theatres, Stages and Public Halls**

NH1.1 Application of Part

NH1.2 Separation and smoke control

NH1.3 Proscenium wall construction

Part

NH1.4 Seating area

NH1.5 Exits from theatre stages

NH1.6 Access to platforms and lofts

**Specifications**

Specification NH1.2  
Construction of Theatres with Proscenium Walls

---



---

## PERFORMANCE REQUIREMENTS

### OBJECTIVES AND REQUIRED PERFORMANCE

This section contains more specific requirements for particular special use buildings.

Specific use buildings must be so designed and constructed that the following objectives, **in addition** to those listed for Sections B, NC, NE, and NF where relevant, are fulfilled.

### NHP1 Theatres, Stages and Public Halls

The audience seating area and egress routes of a Class 9b building used as a theatre, public hall, or the like, must be protected against fire and smoke from any fire occurring on *stage*, in *backstage* areas or in a rigging loft.

---

## DEEMED-TO-SATISFY PROVISIONS

### THEATRES, STAGES AND PUBLIC HALLS

#### NH1.1 Application of Part

This Part applies to every enclosed Class 9b building which-

- (a) has a *stage* and any *backstage* area with a total *floor area* of more than 200m<sup>2</sup>, or
- (b) has a *stage* with an associated rigging loft.

#### NH1.2 Separation and smoke control

The design of smoke control systems for theatres and public halls must fulfill up-to-date fire engineering principles and practices.

A theatre, public hall or the like must-

- (a) have a smoke control system in accordance with AS/NZS 1668.1 where relevant; or
- (b) have a *stage*, *backstage* area and accessible under-stage area, separated from the audience by a proscenium wall and have a mechanical exhaust system, both in accordance with Specification NH1.2.

#### NH1.3 Proscenium wall construction

A proscenium wall and mechanical exhaust system *required* by NH1.2(b) must comply with Specification NH1.2.

#### NH1.4 Seating area

In a seating area in a Class 9b building or part of a building-

- (a) the slope of the floor surface must not exceed 1:8, or the floor must be stepped so that-
  - (i) the *pitch* does not exceed 30°;
  - (ii) it has a riser height not more than 600 mm; and
  - (iii) the height of any opening in the riser is not more than 100 mm;
- (b) if an aisle divides the stepped floor and the difference in level between any 2 consecutive steps-

- (i) exceeds 230 mm but not 400 mm – an intermediate step must be provided in the aisle;

- (ii) exceeds 400 mm – 2 equally spaced steps must be provided in the aisle; and

- (iii) the going of intermediate steps must be not less than 270 mm and such as to provide as nearly as practicable equal treads throughout the length of the aisle; and

- (c) the clearance between rows of fixed seats used for viewing performing arts, sport or recreational activities must be not less than -

- (i) 300 mm if the distance to an aisle is not more than 3.5 m; or

- (ii) 500 mm if the distance to an aisle is more than 3.5 m.

#### NH1.5 Exits from theatre stages

- (a) The path of travel to an *exit* from a *stage* or performing area must not pass through the proscenium wall if the stage area is separated from the audience area with a proscenium wall.

- (b) *Required exits* from *backstage* and under-stage areas must be independent of those provided for the audience area.

#### NH1.6 Access to platforms and lofts

A *stairway* that provides access to a service platform, rigging loft, or the like, must comply with AS 1657.

---

## CONSTRUCTION OF THEATRES WITH PROSCENIUM WALLS

### 1. Scope

This specification contains the requirements for the construction of proscenium walls and mechanical ventilation for theatres, public halls, or the like.

### 2. Separation of stage areas, etc.

(a) Dressing rooms, scene docks, property rooms, workshops, associated store rooms and other ancillary areas must be-

(i) located on the *stage* side of the proscenium walls; and

(ii) separated from corridors and the like by construction having a FRL of not less than 60/60/60 and if of *lightweight construction*, comply with Specification NC1.5

(b) The *stage* and *backstage* must be separated from other parts of the building, other than the audience seating area, by construction having a FRL of not less than 60/60/60 and if of *lightweight construction*, comply with Specification NC1.5.

(c) Any doorway in the construction referred to in paragraphs (a) and (b) must be protected by a *self-closing – /60/30* fire door.

### 3. Proscenium wall construction

A proscenium wall must-

(a) extend to the underside of the roof covering or the underside of the structural floor next above; and

(b) have a FRL of 60/60/60 or more and if of *lightweight construction*, comply with Specification NC1.5.

### 4. Combustible materials not to cross proscenium wall

Timber purlins or other *combustible* material must not pass through or cross any proscenium wall.

### 5. Protection of openings in proscenium wall

Every opening in a proscenium wall must be protected-

(a) at the principal opening, by a curtain in accordance with Clause 6 which is-

(i) capable of closing the proscenium opening within 35 seconds either by gravity slide or motor assisted mechanisms;

(ii) operated by a system of *automatic* heat activated devices, manually operated devices or push button emergency devices; and

(iii) able to be operated from either the *stage* side or the audience side of the curtain; and

(b) at any doorway in the wall, by a *self-closing – /60/30* fire door.

### 6. Proscenium curtains

A curtain *required* by Clause 5 must be –

(a) a fire safety curtain-

(i) made of *non-combustible* material;

(ii) capable of withstanding a pressure differential of 0.5 kPa over its entire surface area; and

(iii) so fitted that when fully closed it inhibits the penetration of smoke around the perimeter of the opening, from the *stage*; or

(b) a curtain –

(i) having a *Spread-of-Flame Index* not greater than 0 and a *smoke-developed index* not greater than 3; and

(ii) protected by a deluge system of open sprinklers installed along the full width of the curtain.

### 7. Mechanical ventilation

Every *stage* must have a system of mechanical ventilation with sufficient capacity to exhaust an amount of air which ever is the greater of-

(a) 5,000 L/s; or

(b) the sum of-

(i) 10 L/s.m<sup>2</sup> of the performing area of the *stage*.

- 
- (ii) 20 L/s.m<sup>2</sup> of the remaining area of the *stage*, and
-