

# A PARTIAL COMMENTARY ON THE NATIONAL BUILDING CODE

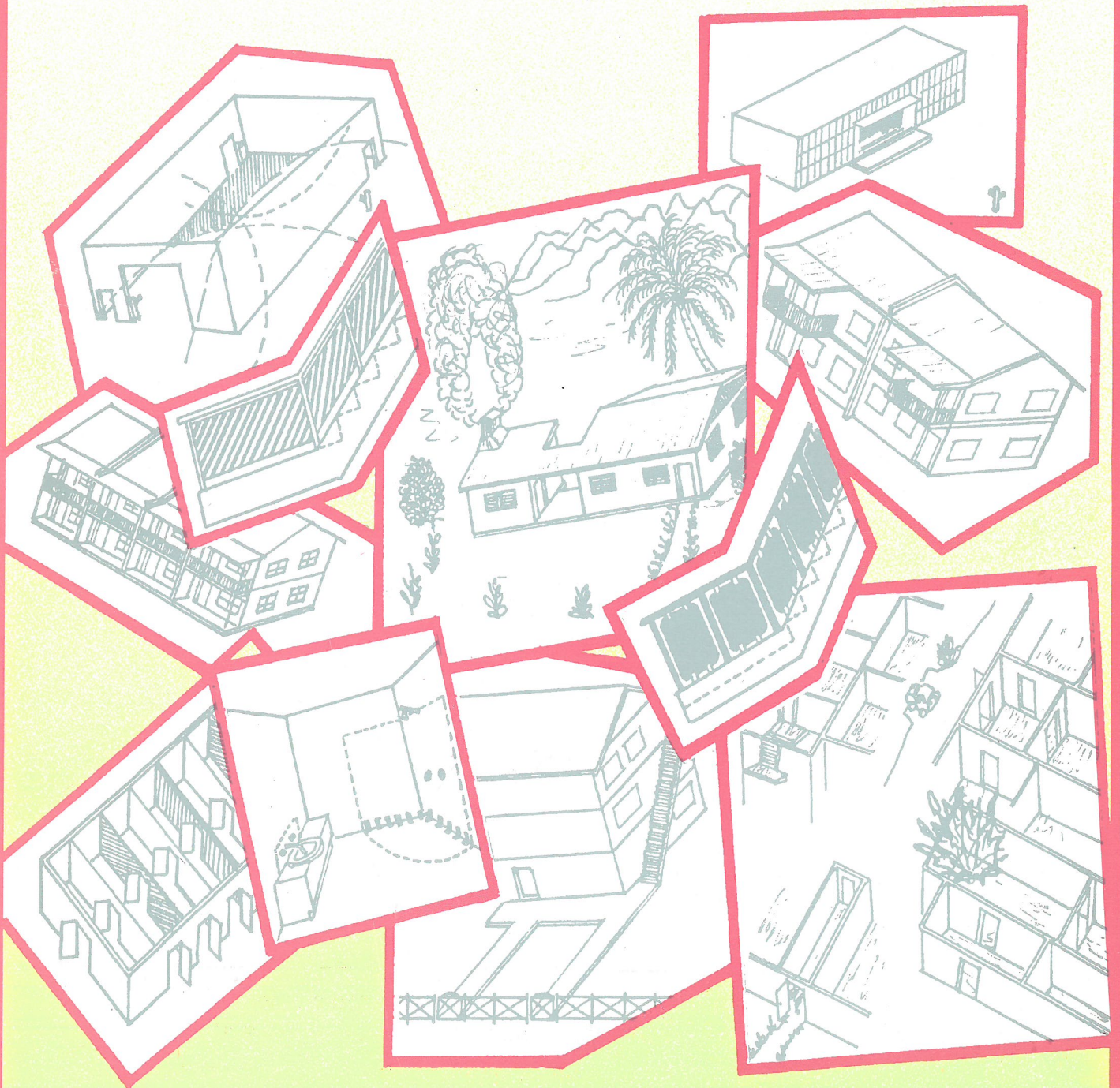

TUVALU

The work on this Commentary was funded by the  
Australian International Development Assistance Bureau

A PARTIAL COMMENTARY  
ON THE  
NATIONAL BUILDING CODE

TUVALU





# CONTENTS

## FOREWORD

### A GENERAL PROVISIONS

#### A1 Interpretation

- A1.1 Definitions
- A1.2 Adoption of Standards and other References
- A1.3 Referenced Standards, etc.
- A1.5 Mandatory Provisions

#### A2 Acceptance of Design and Construction

- A2.2 Evidence of Suitability
- A2.3 Fire Resistance of Building Elements
- A2.4 Early Fire Hazard Indices

#### A3 Classification of Buildings and Structures

- A3.1 Principles of Classification
- A3.2 Classifications
- A3.3 Multiple Classification

#### A4 United Buildings

- A4.1 When Buildings are United
- A4.2 Alterations in a United Building

#### Specification

- A1.3 Standards Adopted by Reference
- A2.3 Fire Resistance of Building Elements
- A2.4 Early Fire Hazard for Assemblies

### B STRUCTURE

- B1.1 General Requirements

### DC FIRE RESISTANCE

#### DC1 Fire Resistance and Stability

- DC1.1 External Walls of Class 1 Buildings

### DD ACCESS AND EGRESS

#### DD1 Construction of Exits

- DD1.1 Treads and Risers
- DD1.2 Curved Stairs
- DD1.3 Balustrades
- DD1.5 Number of Exits

### DE ELECTRICITY

### DF HEALTH AND AMENITY

#### DF1 Damp and Weatherproofing

- DF1.4 Weatherproofing of Roofs and Walls
- DF1.6 Waterproofing of Wet Areas in Building

### DF2 Cooking and Sanitary Facilities

- DF2.1 Facilities Required

### DF3 Room Sizes and Heights

- DF3.2 Reduced Height Permissible

### DF4 Light and Ventilation

- DF4.5 Ventilation of Rooms
- DF4.7 Ventilation Borrowed from Adjoining Rooms
- DF4.10 Sub-floor Ventilation

### DF5 Watersupply Plumbing

- DF5.3 Pipes which are not Easy to Access

### DF6 Sanitary Plumbing and Drainage

- DF6.6 Unvented Branch Drains

### DF7 Roof Drainage

- DF7.1 Design of Roof Gutters

### DG ANCILLARY PROVISIONS

#### DG2 Fireplaces, Chimneys and Flues

- DG2.2 Open Fireplaces Deemed-to-Satisfy

### NC FIRE RESISTANCE

#### NC1 Fire Resistance and Stability

- NC1.1 Type of Construction Required
- NC1.3 Lightweight Construction

#### NC2 Compartmentation and Separation

- NC2.2 General Floor Area Limitations
- NC2.3 Health-care Buildings

#### NC3 Protection of Openings

- NC3.2 Protection of Openings in External Walls
- NC3.3 Separation of Openings in Different Fire Compartments
- NC3.9 Openings for Service Installations

#### Specification

- NC1.1 Fire-Resisting Construction
- NC1.4 Early Fire Hazard Indices
- NC3.2 Fire Doors, Smoke Doors, Fire Windows and Shutters
- NC3.10 Penetration of Walls, Floors and Ceilings by Services

**ND ACCESS AND EGRESS**

**ND1 Provision for Escape**

- ND1.1 Application
- ND1.3 Exit Travel Distance
- ND1.4 Distance Between Alternative Exits
- ND1.5 Dimensions of Exits
- ND1.6 External Stairways
- ND1.7 Travel by Stairways or Ramps
- ND1.8 Discharge from Exits
- ND1.9 Horizontal Exits

ND1.10 Number of Persons Accommodated

ND1.11 Measurement of Distances

ND1.12 Method of Measurement

**ND2 Construction of Exits**

- ND2.1 Application of Part
- ND2.2 Stairways and Ramps
- ND2.3 Installations in Exits and Paths of Travel
- ND2.4 Width of Stairways

**Appendix**

---

## FOREWORD

We had attempted to keep the language and style of the recently completed National Building Code reasonably simple. However we had to remain conscious of the fact that the Code will be called up in legislation as the primary document for building control. This placed some constraints on the language that we could use. A need has therefore arisen for an explanation of the complex provisions of the Code. The Commentary is aimed at satisfying this need to a large extent. The Commentary does not cover the Performance Requirements. These requirements have been couched in terms which would allow suitable flexibility. Any attempt at commenting on any of the Performance Requirements is likely to limit their generality. The Commentary therefore covers only the more difficult clauses of the Deemed-to-Satisfy provisions of the Code.

The time that was available to us to work on the Commentary was unrealistically short. Therefore only those clauses have been commented upon which in our view are the more difficult to understand. We have used plenty of diagrams to illustrate the various situations covered by these clauses.

The Commentary is just a set of comments on the provisions of the Code. The diagrams used are only illustrative examples and not definitive solutions to cover all circumstances. The Code alone is the authoritative document for the purposes of building control. In spite of these limitations the Commentary should help users to find their way through the Code.

When working on the Commentary we noticed some errors in the Code. We have shown these errors and corrections in an Appendix to the Commentary so that it will help Code Administrators to issue formal advice of the corrections.

We have used several of the diagrams employed in the commentary on the Building Code of Australia as a guide to produce our diagrams. We are very thankful for this to the Australian Uniform Building Regulations Co-ordinating Council (AUBRCC) and the staff at the Division of Building, Construction and Engineering of the CSIRO, Australia. In particular I thank Hugh Knox, Manager, Regulations, Accreditations and Standards at the National Building Technology Centre, Sydney who has helped me through our discussions on several of the topics covered. Vishwa Goundar an artist in Suva, Fiji produced the diagrams for the Commentary. He has also produced the cover design. I thank him for his contribution. I am thankful to the Project staff, especially to Sashi Lata Pal, for their dedication in completing the Commentary in a very short time.

Suva : December 1990

Kris Ayyar  
Project Manager  
Pacific Building Standards Project





## SECTION A GENERAL PROVISIONS

### PART A1 INTERPRETATION

#### A1.1 Definitions

The definitions given in the Code are intended to give very specific meanings to the words and phrases used in the Code. Such meanings could be different from dictionary meanings and meanings in the Australian, New Zealand and other Standards called up in the Code. However for the purpose of the Code the defined meanings will have priority over all other meanings.

**Combustible** : All materials are *combustible* under appropriate conditions. For the purpose of the Code a material is deemed to be *combustible* if it fails to pass the requirements of AS 1530.1.

**Effective Height** : The *effective height* is an important measure in terms of the reach of fire fighting equipment. The safer practice will be to consider *effective height* from the lowest entrance level of a building by the side of which it is possible to station a fire engine. The definition however asks to measure *effective height* from the highest *storey* providing egress to a road or *open space*. The marginal reduction in safety is compensated by reduced cost. Measurement of *effective height* is illustrated in Sketch A1.1(i).

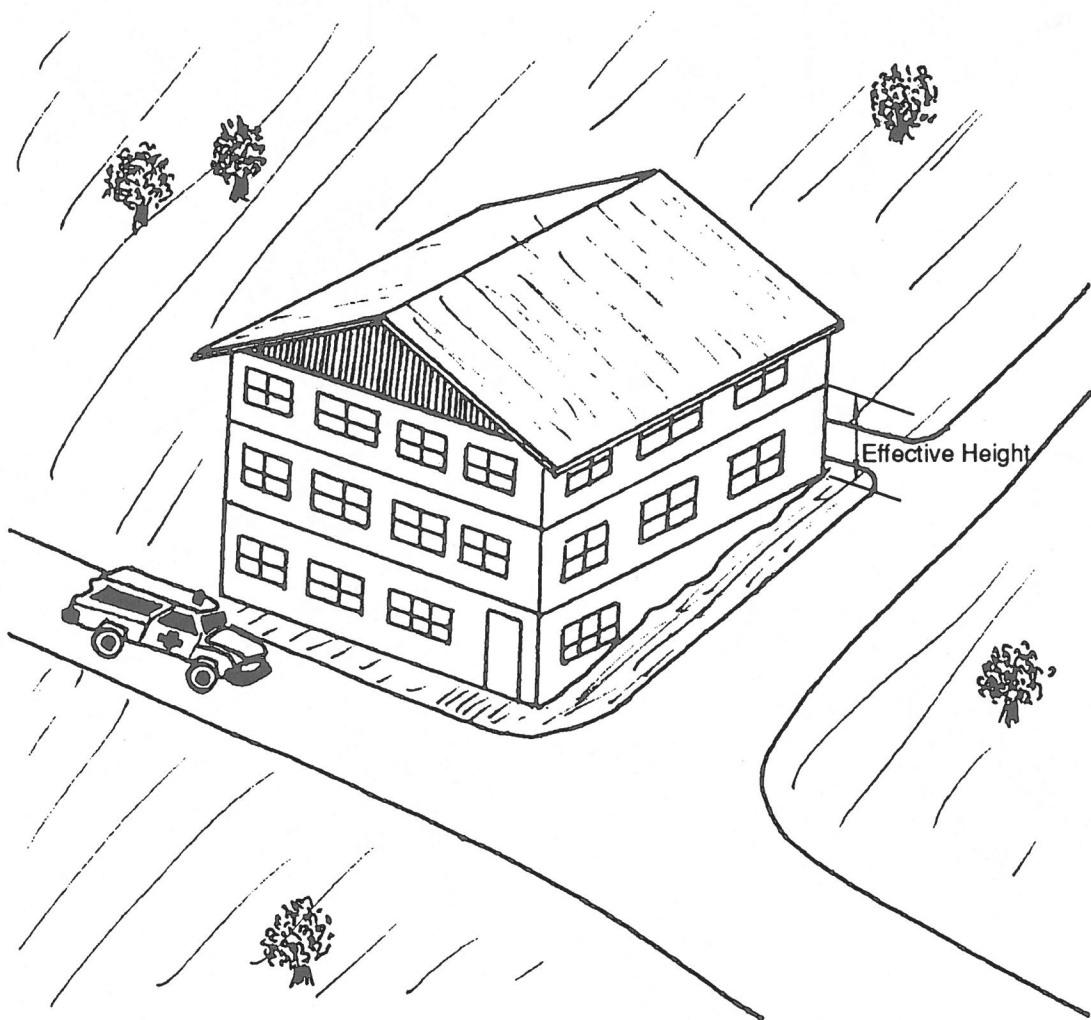

Sketch A1.1(i) Measurement of Effective Height

**Exit :** *Exits* as defined in the Code have the specific purpose of allowing a fast and safe egress in case of any emergency. The term has a range of meanings. A doorway for instance is an *exit* only when it directly opens to a roadway or *open space* unless it is a *horizontal exit*. Some of the different types of *exit* given in the definition are illustrated in Figure A1.1(ii).

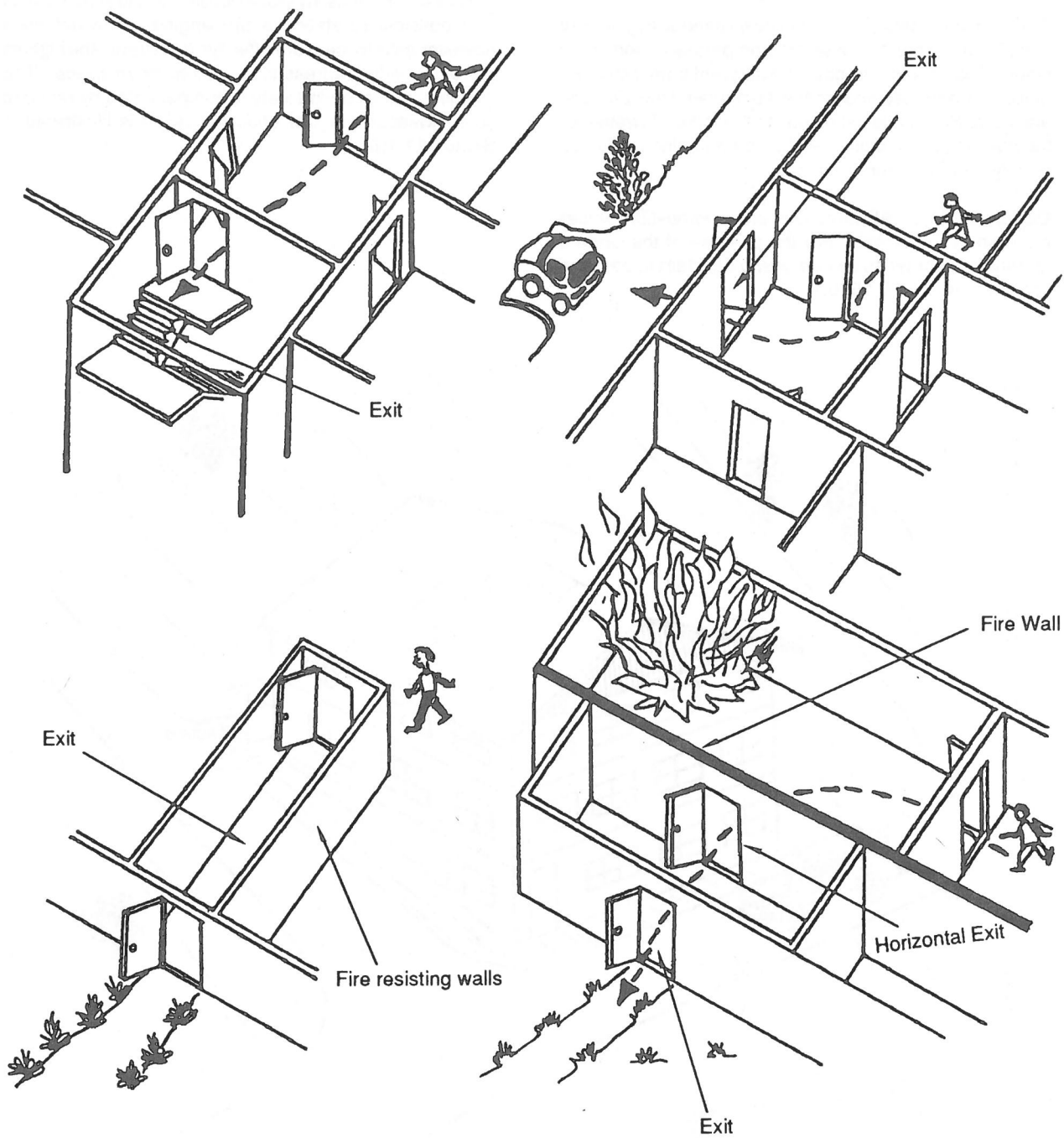

Sketch A1.1(ii) Examples of Exits

**Fire Compartment :** Parts of a building can be separated from other parts by construction which will prevent the passage of fire and smoke from one part to another. Each such part is then known as a *fire compartment*. There is no requirement in the definition that a *fire compartment* should be protected from the spread of fire and smoke from other adjoining buildings. However there are other requirements in the Code which provide for this suitably.

The fire load in a compartment is generally proportional to its *floor area/volume*. Therefore limiting the *floor area/volume* of a *fire compartment* limits the severity and duration of a fire originating in it. Compartmentation protects the occupants from any fire outside the compartment. It also prevents the spread of fire from any compartment where it originated.

Where the fire service is not adequately equipped and manned or where sprinklers are not commonly used or where other such active means of fire protection are of limited availability, limiting the *floor area/volume* of *fire compartments* is an effective means of securing safety against fire.

**Fire-resistance Level :** The fire-resistance of any building element is expressed in terms of three criteria. These are:

*Structural Adequacy* - the element must have sufficient structural strength to continue to bear the loads for which it is designed for a sufficient time after it has been affected by fire.

*Integrity* - it must be capable of withstanding the effects of the fire for a sufficient time without changing shape or warping or undergoing any cracking, any of which might allow flames and smoke to pass through the element.

*Insulation* - it must be capable of limiting any rise in temperature from the fire side to the safe side to a prescribed value.

These are all determined by the standard fire resistance test in accordance with AS 1530.4. The results are expressed in minutes of duration over which the building element is capable of fulfilling the criteria. These are always expressed in the order of *structural adequacy* followed by *integrity* and then by the time for which it has sustained its insulating capability. Usually the times are expressed in multiples of 30 minutes.

An example of the *fire-resistance level* (FRL) of a wall is 90/60/30 which means that it will continue to bear the load for a period of 90 minutes after a fire of severity equivalent to the test fire, to be free from producing any cracking or warping for a period of 60 minutes and prevent any rise in temperature on the non-fire side by more than a prescribed level, for 30 minutes. If the wall is *non-loadbearing* and is only a *fire resisting* partition the very first figure in the value of the FRL would show a blank. In the example taken it would be -/60/30. In the case of a column the FRL will be relevant only for *structural adequacy*. The column by itself cannot prevent the passage of any smoke or flames nor can it prevent any rise in temperature around it. Therefore an example for a column would be 60/-/-. In the case of a fire door it will have no *loadbearing* capability and therefore its FRL will be expressed with the first value shown as a blank. An

example would be -/60/30. If the door in this example is incapable of limiting the rise in temperature from one side to the other its FRL would be -/60/-.

**Fire-source Feature :** This is equivalent to an imaginary burning building. The Code allows buildings to be erected up to the allotment boundary, provided the stated requirements are fulfilled. If such a building were to catch fire it could endanger buildings in the neighbouring allotment through tongues of flame, flying brand, convection and radiant heat. Therefore the definition uses the appropriate land boundaries and the *external walls* of buildings within the allotment as *fire-source features*.

**Flammability Index :** This is determined on the basis of AS 1530.2. It is a composite index that consists of

- (a) the speed with which the material will catch fire,
- (b) the heat produced as a result of burning and
- (c) the extent to which the burning will spread within a given time.

The higher the *flammability index* the more the risk. The values range from 0 to 100.

The test is suitable only for sheet and woven materials which are reasonably pliable such as carpets and wall coverings and which do not readily melt or shrink away from an igniting flame.

**Horizontal Exit :** This has already been illustrated while commenting on *exit*. It must be remembered that a *horizontal exit* is not any door but one which is located in a *fire wall* that is *required* under the Code.

**Non-combustible :** This definition has been given separately for materials and for parts of a building or a construction.

In the case of any material it should not be *combustible* as explained in the definition of that term. However it can have thin finishes such as paint or wall paper with a thickness of no more than 1 mm. The *spread-of-flame index* should not exceed zero (see commentary on *spread-of-flame Index*). When the term is applied to construction or a part of a building, the construction or part must have *non-combustible* material on all exposed faces. The definition further gives a list of specific materials which are considered to be *non-combustible*.

**Professional Consultant :** The definition clearly specifies that the consultant must have appropriate experience in the relevant field. The consultant must either be registered under some existing legislation or must be a full member of a recognised Professional Institution or Association.

**Site :** The definition as given might give the impression that it is only that part of an allotment covered by the outline of the building. Such was not the intention when the term was defined. The term also includes the land in the vicinity of the building which is required to carry out its erection, continued use and demolition. There was however no intention to treat the whole of very large allotments as *site*.

**Smoke-Developed Index:** This is an index which forms part of the early fire hazard properties of materials as tested under AS 1530.3 and relates to the optical density of the smoke produced under test conditions. The index ranges from 0 to 10; the higher the value of the index, the greater the risk from smoke in case of fire. The thickness of the material as well as the weight-to-surface area ratio can affect the amount of smoke produced. Where fire retardants are used the amount of smoke produced will increase in the case of timber and cellulosic materials whereas with plastics, they would reduce the smoke produced.

**Spread-of-Flame Index:** This is also an index measure when a material is tested under AS 1530.3 and relates to the rate of release of heat by a burning material under test conditions of radiant heat. It is applicable to wall lining material. The range of index is from 0 to 10. An index of 10 means that flames can spread through the wall lining to a ceiling at a height of 2.7 m within 10 seconds under standard conditions whereas an index of zero means that flames do not reach the ceiling within 4.5 minutes of test ignition. The use of fire retardants can substantially reduce the *spread of flame index*.

**Window:** The Code definition includes not only windows as are normally understood but also glazed doors, glass brick walls etc. which can transmit natural light from outside a building into a room when in the closed position.

#### **A1.2 Adoption of Standards and other References**

The building Code is a document containing only technical requirements. Matters which form contractual responsibilities should not therefore find any mention in the Code. It is for this reason that this clause specifically excludes any reference in the Australian and New Zealand Standards or other called-up documents, which deal with any matters of a contractual nature.

#### **A1.3 Rereferenced Standards, etc.**

All the Standards such as from Australia and New Zealand which are called-up in the Code refer to the latest edition of such Standards. These Standards are periodically revised by the organisations in the countries concerned. Code administrators should keep aware of changes to such Standards so that if any incompatibility arises as a result of a revision to a Standard an appropriate amendment to the Code is issued to exclude the effects of any such incompatibility.

#### **A1.5 Mandatory Provisions**

It is important to remember that the mandatory provisions of the Code are only the provisions of Section A and the Performance Requirements stated at the beginning of all other Sections. This in theory would allow a wide latitude for the designers/builders. Code administrators will find it very difficult to handle such a wide diversity of possibilities because of the very limited technical resources available to them to ensure that the mandatory provisions are fully met. This is why sub-section (b) of this clause demands that when designers/builders adopt the flexibility of using the Performance Requirements they are obliged to ensure that the final objectives and performance achieved are no less than what they could have achieved had they followed the deemed-to-satisfy provisions of the Code.

In the case of most normal buildings the trouble and expense of proving that any performance route adopted can achieve not less than the objectives and performance of the deemed-to-satisfy provisions, will discourage the use of this route. However such trouble and expense can be justified in the case of complex/large buildings by the overall savings possible.

Code administrators must remember that it is the objectives and performance attainable by the use of the deemed-to-satisfy provisions that are to be compared with what is proved to be achievable by the performance route. The details of the deemed-to-satisfy provisions are not relevant for such comparison and judgement. The onus of producing the proof for such comparison rests with whoever applies for the building permit.

### **PART A2 ACCEPTANCE OF DESIGN AND CONSTRUCTION**

#### **A2.2 Evidence of Suitability**

This clause does not specifically require any legislation to support accreditation of building products. However if appropriate legislation were introduced and an appropriate administrative machinery set up it will allow for the easy acceptance of suitable products throughout the country without the need for satisfying each Approving Authority separately.

#### **A2.3 Fire Resistance of Building Elements**

See commentary on Specification A2.3.

#### **A2.4 Early Fire Hazard Indices**

See commentary on Specification A2.4.

### **PART A3 CLASSIFICATION OF BUILDINGS AND STRUCTURES**

#### **A3.1 Principles of Classification**

The purpose for which a building is designed, constructed or adapted, legally determines the use to which the building can be put. Such use governs the risks associated with the building for its users and the public. This is the reason for the particular manner in which buildings have been classified in the Code.

#### **A3.2 Classifications**

**Class 1 Buildings** This is a classification which essentially deals with a single dwelling house or very simple forms of multiple dwellings. The different sub-classifications given are :

- (a) a single house in its allotment;
- (b) a large house some rooms of which are rented out to transient residents. The sub-classification would normally have belonged to Class 3. However by including it in Class 1 some concessions have been given. It will allow the operation of low tariff guest houses with the attendant advantages to the less affluent users. By limiting the total number of residents to 12 (including any permanent residents such as the owner's family) the overall risk to life and health is kept under check.



- (c) This sub-classification is subdivided into two. The first one is where there can be a number of *sole-occupancy units* separated by *common walls*. The second division allows for a building in which there are a total of only 2 *sole-occupancy units* located one above the other. In the case of sub-classification (c) each *sole-occupancy unit* must have its own direct egress to a road or *open space* without having to go through another *sole-occupancy unit*.

Examples of the sub-classifications (a) and (c) are shown in the attached sketches.

### A3.3 Multiple Classification

Quite often separate parts of a *storey* are put to different uses and therefore each part will need to be classified separately. In such a case it is necessary to have the part pertaining to each Class to fully comply with the detailed requirements for that Class. However there may be cases where only a very small part of the *storey* is put to a use different from that of the major part. In order to consider such cases the following two questions must be asked :

- (i) does at least 90% of the *storey* pertain to one Class by virtue of the use to which it is put?



Sketch A3.2(a) Example of a Class 1 Building - A Single Dwelling with a Detached Kitchen

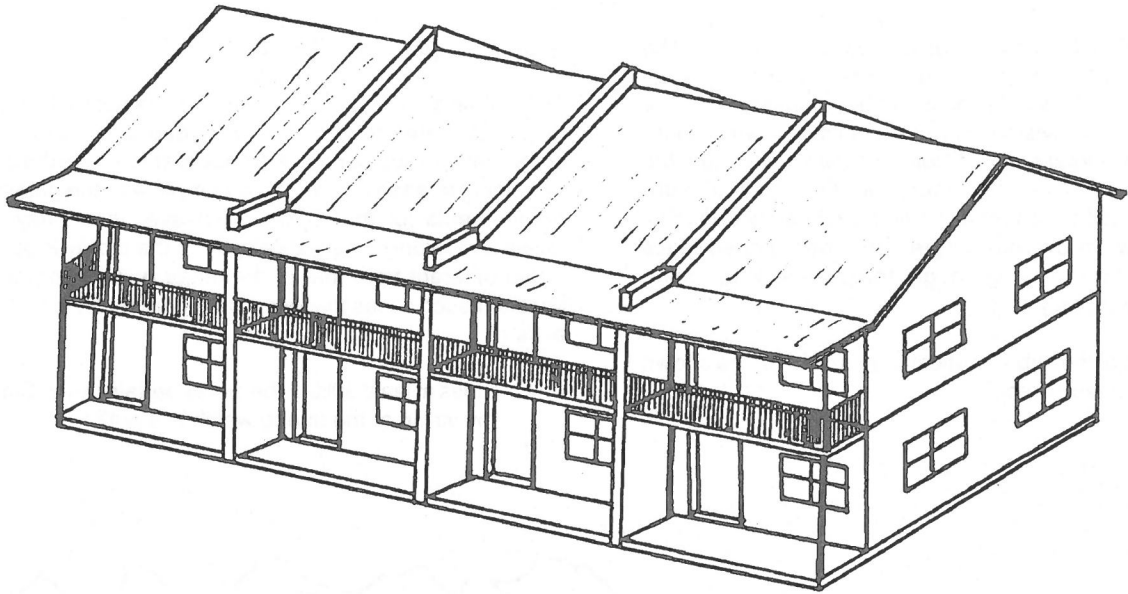

Note : Each unit must have an independent egress to a road or open space

Sketch A3.2 (c) (i) Example of a Class 1 Building - A Number of Sole-Occupancy Units Separated by Common Walls

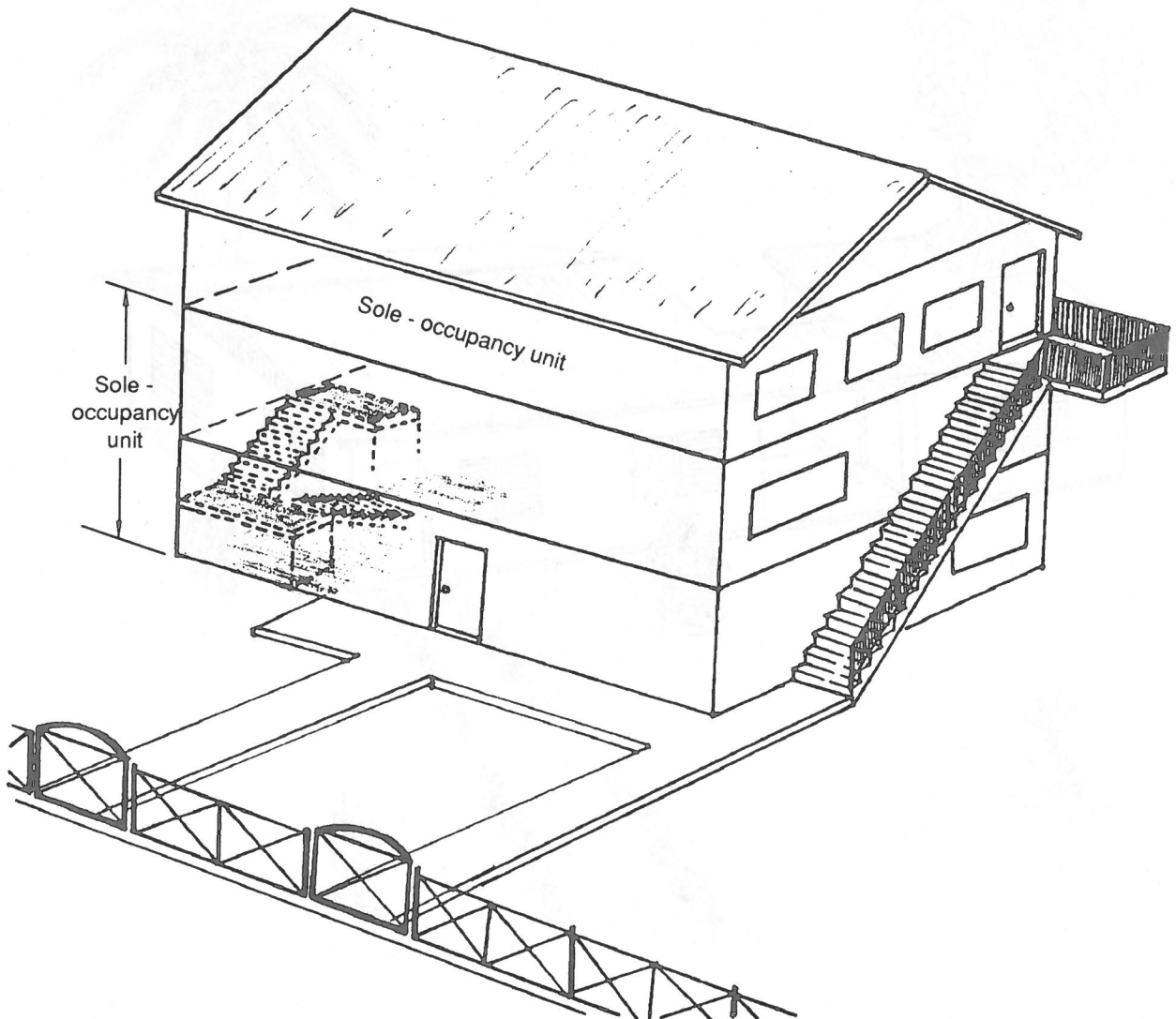

Sketch A3.2 (c) (ii) Example of a Class 1 Building - Two Sole-Occupancy Units Each With Independent Direct Egress to a Road or Open Space

- (ii) Is the remaining part used for purposes other than a laboratory?

If the answers to both the questions are "yes" then the whole *storey* may be classified as appropriate for the major purpose.

## PART A4 UNITED BUILDINGS

### A4.1 When Buildings are United

Some building owners may find it advantageous to have two or more adjoining buildings interconnected through openings in the dividing walls between them. In such a case it is allowable to treat the interconnected buildings as a single building. The dividing walls can be treated as *internal walls* and if any of these walls are on a boundary they are not treated as *fire-source features*. The requirements for openings in *external walls* will not apply (whereas other requirements for separation etc. might apply).

Treating the interconnected buildings as a single building will also mean that the *floor areas* will increase. If the *internal walls* have to be *fire-resisting* the openings in such walls will also need to be protected with fire doors etc. as required in Part NC3.

### A4.2 Alterations in a United Building

The distinction between the meanings of *alteration* and *repair* as given in the definition at Part A1 of the Code must be clearly understood. If any *alteration* is done in a united building the altered building and parts must comply with the requirements of the Code. For instance if a dividing wall is on a boundary and the interconnecting opening in it is walled-up the boundary will become a *fire-source feature*.

### Specification A1.3 Standards Adopted by Reference

The Code calls up either Australian or New Zealand Standards as *required*. In a few instances it calls up either one or the other. Where only the Australian Standards or the New Zealand Standards have been called up, Code users are allowed to make use of the equivalent New Zealand or Australian Standard. However when this is done it is necessary to ensure technical consistency. While adopting AS 1170 Part 2, the New Zealand Standard NZS 4203 deletes the requirements for cyclone effects. Therefore NZS 4203 Part 4 is not appropriate for use with this Code. The other parts (1, 2 & 3) of NZS 4203 are

appropriate. It should be noted that the Standards Association of Australia and of New Zealand have decided to progressively modify their individual Standards to common Standards applicable to both countries. In a few short years the majority of important Standards will be common for both countries.

### Specification A2.3 Fire Resistance of Building Elements

This Specification gives the *fire-resisting* properties of some of the building elements listed in it. It permits the calculation of the FRL of building elements based on the results of tests on prototypes. It must be remembered that any fire engineering calculations must be performed by a *Professional Consultant*.

### Specification A2.4 Early Fire Hazard for Assemblies

These tests are done to comply with AS 1530.3. They apply to wall lining materials. The tests are based on a progressive increase in intensity of radiant heat which simulates what could reasonably happen during the early development of a fire. The early fire hazard indices are as follows:

- 1 Ignitability Index,
- 2 Spread-of-Flame Index,
- 3 Heat Evolved Index, and
- 4 Smoke-Developed Index

The *spread-of-flame index* and *smoke-developed index* have already been explained while commenting on the definition of these two terms in Part A1. The ignitability index relates to the time taken under standard test conditions when the volatile products from the material can easily be ignited by a small flame. The index is zero if ignition does not take place under the conditions. The maximum value of the index is 20 which indicates quick ignitability.

The heat evolved index relates to the amount of heat released by a burning material. The index ranges from 0 to 10 and the higher the index the more the heat released and the involvement of the material in setting fire to other *combustible* materials nearby. The heat evolved index can be affected by the thickness of the material and its weight-to-surface ratio. Where fire retardants are effectively applied to materials the heat evolved index can be reduced.





## SECTION B STRUCTURE

This section of the Code takes up only a few pages although the structural performance of buildings is extremely important to ensure the safety of the users and the public. This is because structural engineering is a highly developed technology as compared for instance to fire engineering. This allows the structural requirements of the Code to be principally listed in terms of appropriate structural Standards for design and materials.

### B1.1 General Requirements

This clause demands provision against progressive collapse. This is mentioned because a relatively minor failure in a part of a structure can initiate a sequential set of failures in adjoining parts. The total damage would be

substantial. Such progressive collapse has occurred in prefabricated structures. In such structures care must be taken to design, fabricate and erect adequate connections to take care of all likely forces. The tolerances specified in the design must not be exceeded in fabrication and erection.

Other precautions against progressive collapse include:

- 1 Designs that take into account severe local effects such as from explosion and the impact of vehicles, and
- 2 Design elements such that the failure of a critical element does not lead to the failure of the whole structure although other elements in it might be over stressed until remedial action is taken.



## SECTION DC FIRE RESISTANCE

Statistics in countries around the world indicate that the majority of deaths and injuries as a result of fire, takes place in small domestic incidents. However building codes around the world are in general far less stringent on fire safety requirements for single dwellings as against the requirements for multiple dwellings and commercial buildings. One possible reason is that in the case of single dwellings the responsibility for prevention of uncontrollable fire usually rests with the owner and/or the residents. Secondly individual domestic incidents although they might result in great tragedy for the family concerned, do not affect large numbers of the public as would be the case with multiple dwellings and commercial buildings.

The provisions in this Section of the Code which apply to Class 1 buildings reflect the trend in other countries in that they are very minimal.

### PART DC1 FIRE RESISTANCE AND STABILITY

#### DC1.1 External Walls of Class 1 Buildings

As long as Class 1 buildings are set back from the boundary and other buildings within the allotment the specified minimum distance, there is no need to comply with any fire resistance requirements. There are further concessions for Class 1 buildings allowed under other clauses in this Part.





## SECTION DD ACCESS AND EGRESS

### PART DD1 CONSTRUCTION OF EXITS

#### DD1.1 Treads and Risers

Going up or down a very large number of consecutive steps in a stairway without intermediate landings for breaking the upward/downward motion can be very tiresome. This is why the maximum number of risers in any one flight is limited to 18. The relationship between the dimensions of the goings and risers given in Table DD1.1 of the Code are based on the attached Sketch DD1.1. The sketch illustrates the safe *pitch* for ramps, stairs and ladders.

The openings between risers have been limited to 100 mm because detailed statistics have shown that any larger opening will be unsafe for small mobile children.

#### DD1.2 Curved Stairs

The requirements of this clause are intended to ensure the safety of the users without limiting practicality.

#### DD1.3 Balustrades

Once again the requirements of this clause emphasise the need for safety especially of small mobile children.

#### DD1.5 Number of Exits

A minimum of two *exits* has been specified. One of these *exits* can even be a *window* or a trap door. However when such unconventional *exits* are used the code specifies the minimum conditions which will ensure that they are safely usable during any emergency.

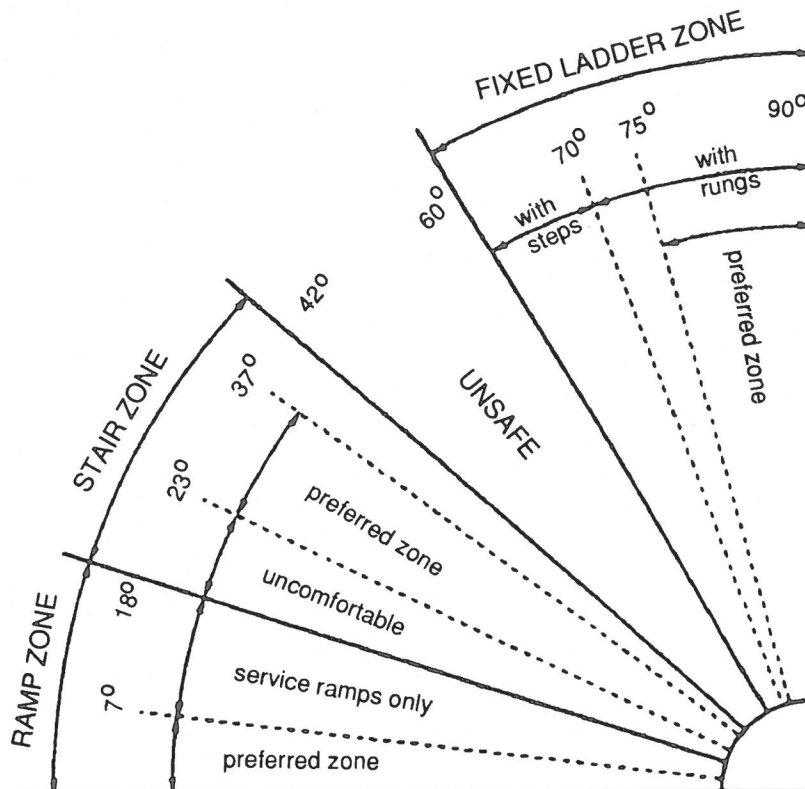

Sketch DD1.1 Recommended Pitch for Ramps, Stairs and Ladders



## SECTION DE ELECTRICITY

The Australian Wiring Rules AS 3000 has been prescribed as the principal reference document for electrical safety. There is no corresponding single document published in New Zealand. In fact the New Zealand Ministry of Commerce has taken a decision to change over completely to AS 3000 and are already in the process of making this

change. They are progressively issuing "Codes" to replace or add to provisions in their wiring Regulations. These "Codes" are extracts from AS3000. Sufficient time will be given by them for industry and practitioners to catch up with the total change over to AS 3000.

---



## SECTION DF HEALTH AND AMENITY

### PART DF1 DAMP AND WEATHERPROOFING

#### DF1.4 Weatherproofing of Roofs and Walls

The code does not spell out any particular Standard for roof coverings. The current practice in the country is to use metal roofing, various brands of metal tiles etc. Heavier roof coverings such as clay tiles are not generally used. It is relevant to note that heavy roof coverings will increase the risk of damage during earthquakes.

Roofing manufacturers usually provide sufficient information on the correct ways of fixing their products. In addition many of them have had their products tested by recognised laboratories and have with them certificates to show the extent to which their products can withstand cyclonic wind loads. The cyclic change in forces on the roof during cyclones substantially weaken the roofing material and its immediate fasteners. The hairline cracks/burrs produced when holes are drilled or punched in roofing sheets act as starting points for failure especially when the strength of the roofing material is substantially reduced as a result of cyclic loading. For the same reason when straps are used as fasteners, it is far better to buy them with factory punched holes.

With some fasteners such as roofing screws special cyclone washers are available. These washers help to reduce the force on the roofing material close to the fastener where the roof is structurally at its weakest.

The only manufacturers known to us who manufacture such special load-spread washers for use with nails are:

Hylton Parker Fasteners  
P O Box 31-401  
Milford  
Auckland  
New Zealand

The cyclic pattern of loading during high winds also affects the fasteners in another way. If there is any slackness in the fastener (whether it be screws, nails, straps, fencing wire etc.) it would contribute to a sudden weakening of the fastener material and failure can be at much lower loads than otherwise. For this reason no slackness should be left in any fastener system used.

#### DF1.6 Waterproofing of Wet Areas in Building

The provisions in this clause can be improved in many innovative ways. However any variation from conventional practices might not be acceptable to approving authorities unless evidence is produced to show otherwise. AS 3740 which deals with the weatherproofing of wet areas within residential buildings gives details of construction techniques for wall/floor areas. Sketch DF1.6 shows the extent of waterproofing *required* by this clause.

Note : Areas within dotted lines shown around shower and the basin tap must be waterproof.

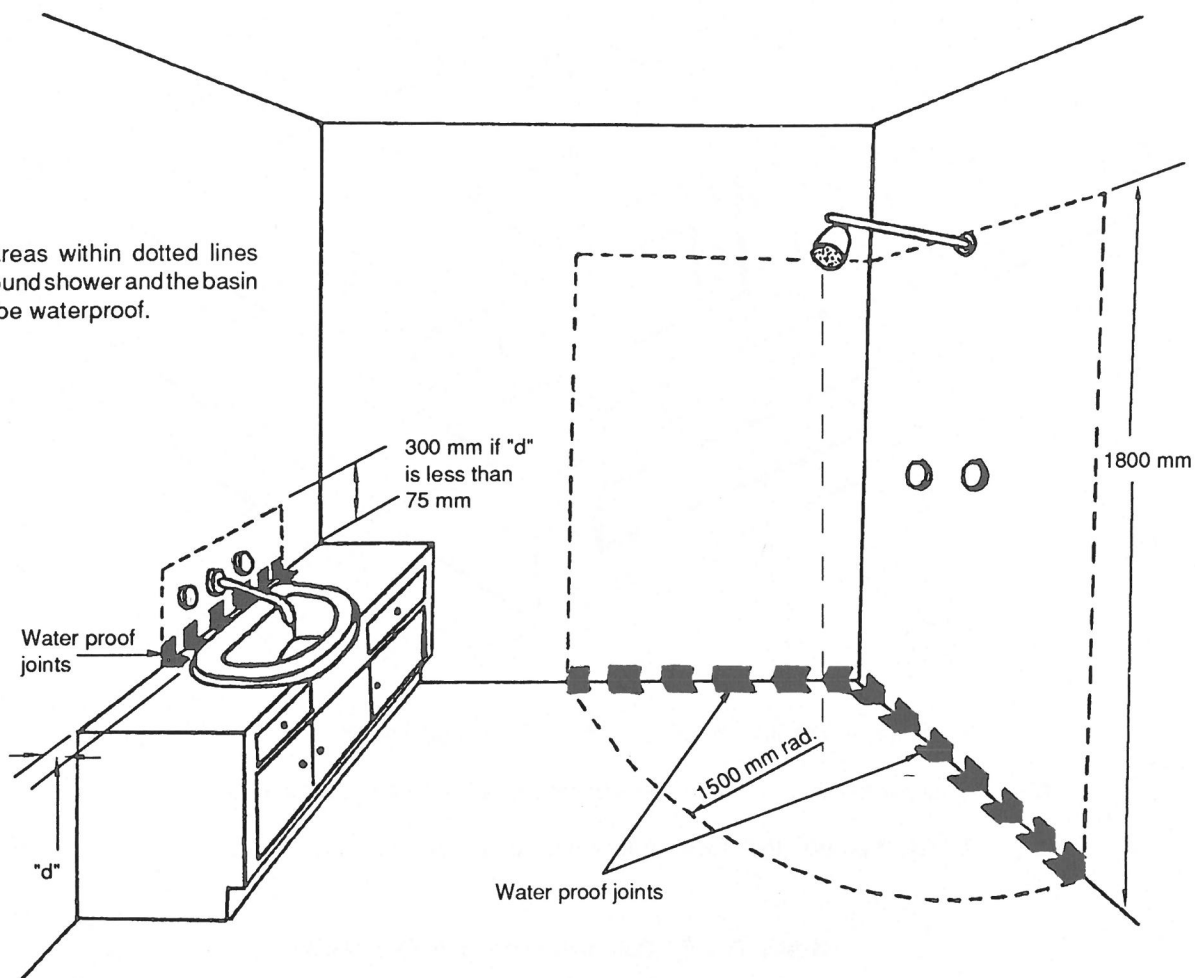

Sketch DF1.6 Requirement for Water Proofing of Areas Around Showers, Basins, Sinks, etc.

## PART DF2 COOKING AND SANITARY FACILITIES

### DF2.1 Facilities Required

The facilities called up in this Clause are the absolute minimum that will ensure the maintenance of satisfactory health and sanitation.

## PART DF3 ROOM SIZES AND HEIGHTS

### DF3.2 Reduced Height Permissible

This clause permits the building of A-framed dwellings and other such designs without undue restriction.

## PART DF4 LIGHT AND VENTILATION

### DF4.5 Ventilation of Rooms

This clause *requires* natural ventilation for *habitable rooms, sanitary compartments* etc. However an allowance is given to provide mechanical ventilation where it is not practical to provide natural ventilation for toilets, laundries

and such like. A mechanical ventilation system is *required* to comply with AS 1668.2. It is pointed out that the requirements of AS 1668.2 are quite exhaustive and compliance will only be necessary as is relevant to the particular application. For instance in the majority of the cases a suitably placed exhaust fan with the exhaust air being discharged outside the building should be sufficient.

### DF4.7 Ventilation Borrowed from Adjoining Rooms

The principle of borrowing ventilation and lighting with the provision of *required* areas of openings is illustrated in the attached Sketch DF4.7.

### DF4.10 Sub-floor Ventilation

The moisture that evaporates from the soil beneath a building can damage the material of the floor especially if it is of timber and create dampness and unpleasant odours. Damage can arise from rotting or attack by termites, dissolved salts penetrating into masonry supports as well as the rusting and other corrosion of metal framing components. In the case of timber flooring the clearances provided from the ground are the very minimum.

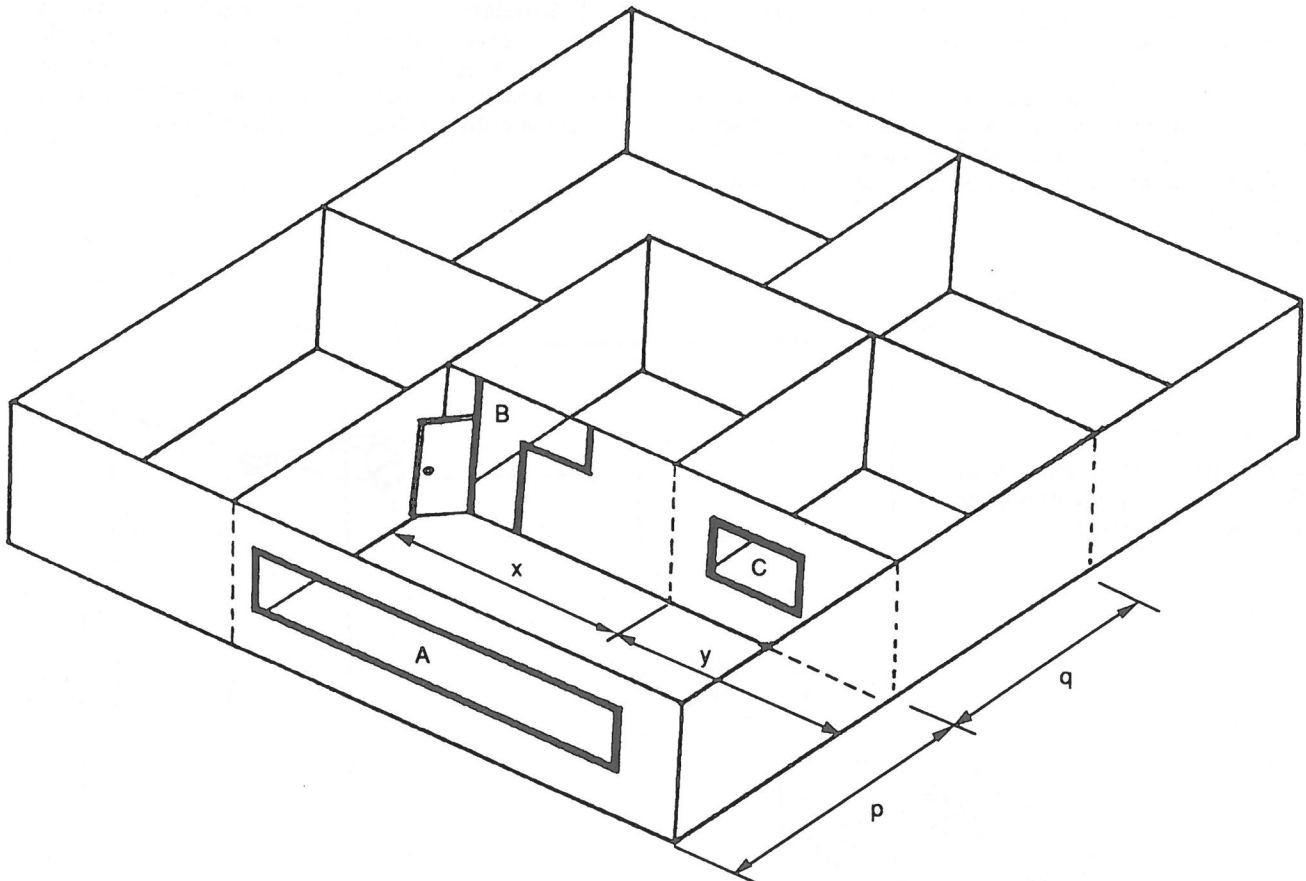

- A must comply with the Code requirements for a floor area equal to  $(p + q) \cdot (x + y)$
- B must comply with the Code requirements for a floor area equal to  $x \cdot q$
- C must comply with the Code requirements for a floor area equal to  $y \cdot q$

Sketch DF4.7 Borrowed Lighting and Ventilation

## **PART DF5 WATERSUPPLY PLUMBING**

### **DF5.3 Pipes which are not Easy to Access**

There are many practical instances where watersupply pipes embedded in walls are damaged due to corrosion, heat or water hammer. If failure and leakages occur it becomes very expensive to locate the faults and repair the damage. In the mean time there will be continuing nuisance and dampness.

## **PART DF6 SANITARY PLUMBING AND DRAINAGE**

### **DF6.6 Unvented Branch Drains**

This clause refers to the cases where the risk of dangerous and unpleasant gases escaping into occupied premises is "minimal". The term "minimal" can lead to disputed interpretation. However the concession given is very much limited by the requirements of sub-clauses DF6.6.1 and DF6.6.2 of the Code.

The risk of escape of dangerous and unpleasant gases into occupied premises is most relevant to connections :

- from en-suite toilets/bathrooms which can affect sleeping occupants, and

- from kitchens in those cases where the dining area is not separated by walls from it.

In all other cases these risks can be taken without serious consequences. With all the limitations to the concession the number of occasions and the duration of such occasions when dangerous/unpleasant gases can escape would be quite small.

## **PART DF7 ROOF DRAINAGE**

### **DF7.1 Design of Roof Gutters**

The sizing of eaves gutters is much less stringent than that of external box and valley gutters. With eaves gutters the damage that is likely to be done to the building and the inconvenience to the occupants will generally be less serious than overflow from internal and valley gutters. This is why a provision has been made for the design of internal and valley gutters to *require* a capacity that is sufficient for a 100 year return rainfall intensity whereas the corresponding period for eaves gutters is only 20 years. This also explains the reason for the greater free board and greater longitudinal slope *required* for internal box gutters as compared to eaves gutters.





## SECTION DG ANCILLIARY PROVISIONS

### PART DG2 FIREPLACES, CHIMNEYS AND FLUES

#### DG2.2 Open Fireplaces Deemed-to-Satisfy

In the case of external kitchens the fire place meant for cooking is not intended to be covered by this clause.

---



## SECTION NC FIRE RESISTANCE

There are two broad methods of protecting a building from fire. These are :

- (a) Passive protection in which fire in any particular part of the building is contained by the use of fire resisting construction. The materials used and their disposition and layout give the building protection.
- (b) Active fire protection in which suitable equipments are brought into action to prevent the spread of fire. These include sprinklers, fire hoses, the use of the fire service and so on.

This Section deals with the passive methods of fire protection.

The fire hazard to a building is determined by a combination of the use to which the building is put, the fire load in the building, its height, the openings in the building envelope, and the distance from other buildings. The intended use of a building is denoted by the system of classification given in the Code at Section A.

### PART NC1 FIRE RESISTANCE AND STABILITY

#### NC1.1 Type of Construction Required

The requirements are relatively simple. All Class 2 and 3 buildings are required to conform to a single Type of construction as detailed in Specification NC1.1.

#### NC1.3 Lightweight Construction

The main requirement for *lightweight construction* is the need to prevent any likelihood of mechanical damage to it. Any mechanical damage can substantially reduce the *integrity and/or insulation* criteria of fire resistance and thereby reduce or negate its intended purpose.

### PART NC2 COMPARTMENTATION AND SEPARATION

#### NC2.2 General Floor Area Limitations

The size of the *fire compartment* reflects the possible fire load and therefore the severity and duration of any likely fire. The active fire fighting facilities available in the country are substantially limited. These considerations are reflected in the limitations to the maximum *floor areas* and volumes of any *fire compartment*. *Health-care buildings* have more stringent requirements (clause NC2.3).

#### NC2.3 Health-care buildings

The limitations on the sizes of *fire compartments* in *health-care buildings* are quite logically different from those of other buildings. These limitations are illustrated in Sketch NC2.3.

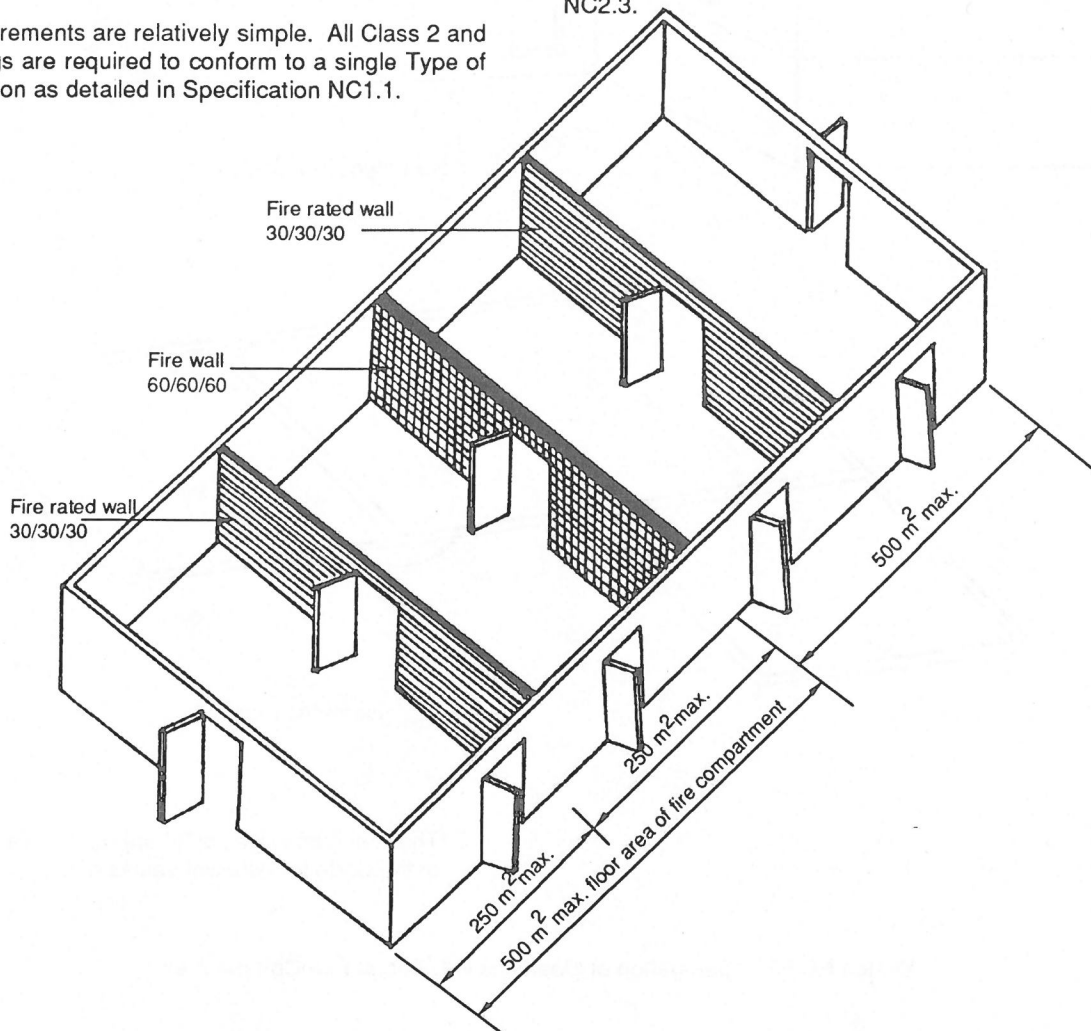

Sketch NC2.3 Limitations of Size of Fire Compartment in Ward Areas of Health-Care Buildings

**PART NC3 PROTECTION OF OPENINGS**

**NC3.2 Protection of Openings in External Walls**

Fire can spread from one building to another through direct attack by flames, convection of heat, radiation or by flying brands. It is very impractical and uneconomical to provide the fire resistance to openings that is applicable to walls and other building elements. Therefore the more

the openings, the greater the vulnerability of the building to fire. Keeping 1.5 m away from any *fire-source feature* will reduce the risk of fire spreading from one building to another.

**NC3.3 Separation of Openings in Different Fire Compartments**

The requirements of this clause are illustrated in Sketch NC3.3.

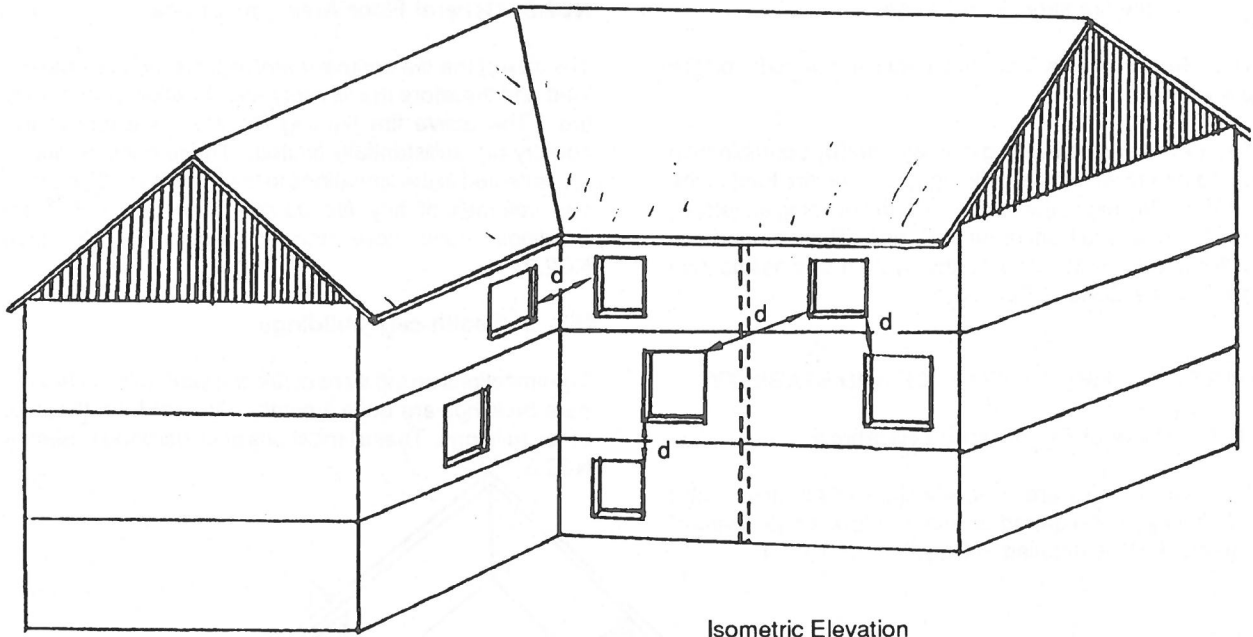

Isometric Elevation

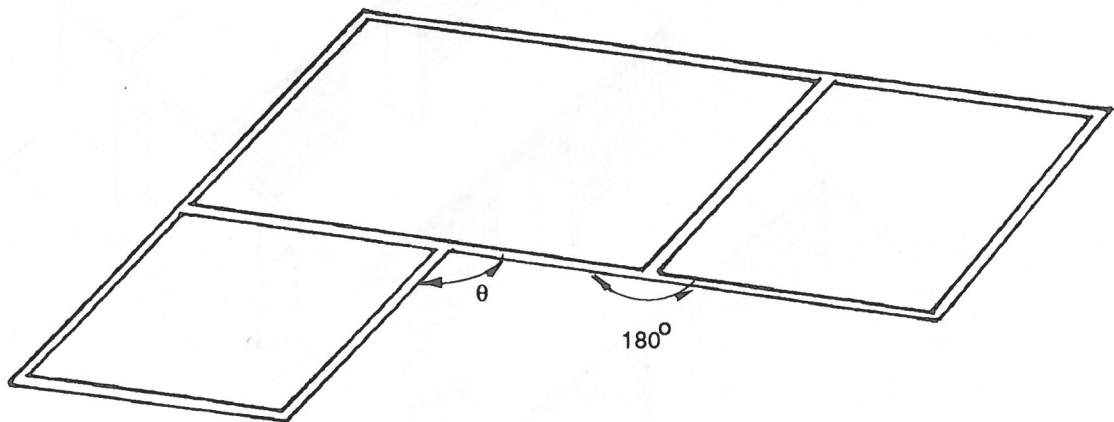

Isometric Plan

The minimum values of "d" are listed in Table NC3.3 of the Code for different values of  $\theta$

Sketch NC3.3 Separation of Openings in Different Fire Compartments

### NC3.9 Openings for Service Installations

This clause exempts the *external wall* and the roof from the requirement that their FRL or a *resistance to the incipient spread of fire* be maintained where services such as electrical cables, plumbing, etc. penetrate them. In the case of all other building elements any penetration must not impair the FRL or the resistance to the *incipient spread of fire*. The concessions to the *external wall* and roof are based on the following:

- in general *external walls* are sufficiently away from a *fire-source feature* that impairment to fire resistance properties at the isolated location where services penetrate them do not reduce safety in any appreciable way.
- usually for the sake of aesthetics and for prevention of rain penetration all openings are reasonably closed to a good standard.

The concessions given in this clause will also enable to have an economical location in buildings of principal facilities such as toilets adjacent to the external envelope.

### NC3.10 Installation Deemed-to-Satisfy

Sub-clauses (a) to (f) list various methods of satisfying

the requirements of clause NC3.9. These measures are further amplified in Specification NC3.10. Where none of these deemed-to-satisfy provisions are applicable the designer/builder will have to produce a solution acceptable to the Approval Authority as satisfying the requirements of NC3.10.

## SPECIFICATION NC1.1 FIRE-RESISTING CONSTRUCTION

### 2 GENERAL REQUIREMENTS

#### 2.1 Exposure to Fire-Source Features

The commentary explains *fire-source feature* as equivalent to an imaginary burning building. According to the Code definition this is the far boundary of a road adjoining the allotment, a side or rear boundary of the allotment, or an *external wall* of another building on the same allotment which is not of Class 10. Sub-clause (a) states that a part of the building element is exposed to a *fire-source feature* if there is no obstruction to any horizontal line between that part and the *fire-source feature* or a vertical projection of the feature. Any obstruction to be considered effective in preventing exposure must have a FRL of not less than 30/-/. Further such obstruction must not be transparent or translucent. These are illustrated in Sketch Spec NC1.1 (i).

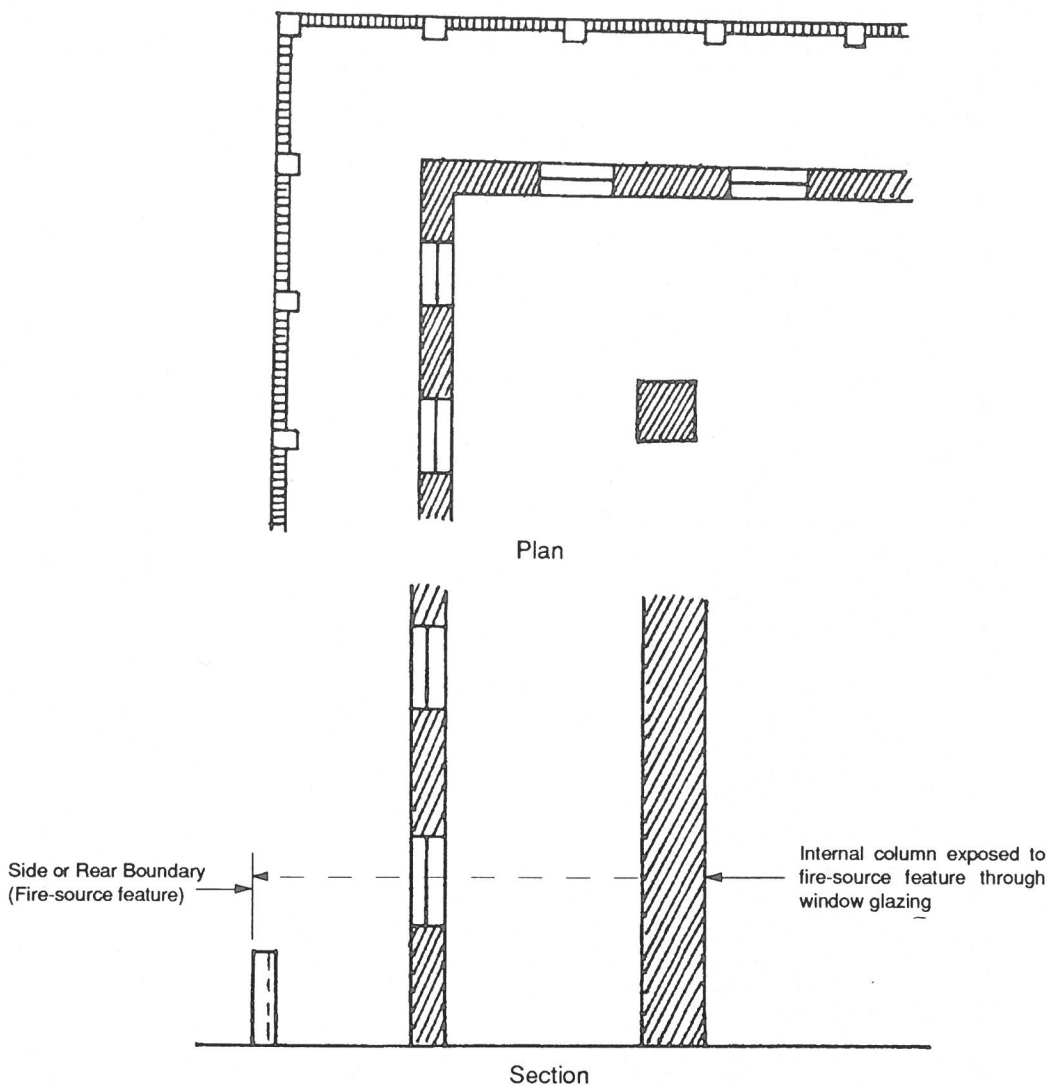

Sketch Spec NC1.1 (i) Exposure to Fire-Source Feature

Sub-clause (b) complements the requirements regarding distances to *fire-source features* given in Table 3 of this Specification. The shorter the distance to a *fire-source feature* the greater the risk from fire. This sub-clause *requires* that any building element which is at varying distances from a *fire-source feature* must have the FRL applicable to the closest distance. A concession given by this clause is if the building element is divided into different independent parts then each part need only satisfy the FRL applicable to its shortest distance from the *fire-source feature*. When this sub-clause is applied it must be remembered that it does not override clause 2.2.

#### **SPECIFICATION NC 1.4 EARLY FIRE HAZARD INDICES**

The different indices which denote early fire hazard have already been explained in the commentary. These indices are ignitability index, heat evolved index, *spread-of-flame index*, and *smoke-developed index*. The limitations for these indices for various uses given in the Specification will ensure reasonable safety for the occupants of the buildings concerned.

#### **4 Fire-Retardant Coatings**

While using fire-retardant coatings the precautions given under this clause in the Specification must be followed; otherwise it could lead to danger to occupants.

#### **SPECIFICATION NC3.2 FIRE DOORS, SMOKE DOORS, FIRE WINDOWS AND SHUTTERS**

Fire/smoke doors, fire *windows* and shutters were earlier not available with sufficient ability to provide high *insulation* levels. However in recent times good quality fire/smoke doors, *windows* and shutters have been developed. It is essential that these items not only comply with the FRL requirements as purchased but also when fixed in position and used. Regular maintenance should be carried out by qualified persons on fire/smoke doors, fire *windows* and shutters. These come in complete assemblies including hinges, door closers, etc. Test certificates and performance apply to the total assembly. Any variation even in minor detail could seriously reduce the performance.

#### **SPECIFICATION NC 3.10 PENETRATION OF WALLS, FLOORS AND CEILINGS BY SERVICES**

This Specification gives the details by which penetration of building elements or installation of services etc. does not impair the *fire resistance levels* of those elements. There are several instances where fires have destroyed buildings through neglect to ensure proper levels of fire stopping of such penetrations, even though all the building elements had the *required* levels of fire resistance.

## SECTION ND ACCESS AND EGRESS

One of the primary aims of this Section is to ensure that in an emergency all occupants of a building are able to get safely out of it in as short a time as is practical. Studies of experimental and actual fires have shown time and again that the alertness of the occupants, their familiarity with escape routes and prompt communication of any developing emergency are more important in saving lives than technical innovations and built-in preventive measures. While the Code cannot lay down standards for levels of awareness of the occupants in relation to escape routes it is desirable that building owners and occupiers incorporate the conduct of periodic escape drills to suit varying scenarios. However awareness and regularity of training cannot be relied upon in every case and therefore the need for passive and active fire protection.

### PART ND1 PROVISION FOR ESCAPE

#### ND1.1 Application

The internal parts of *sole-occupancy units* in Class 2 buildings are excluded from the application of this Part for the reason that even transient occupants of *sole-occupancy units* will be able to have a good knowledge of the escape route within the unit. The Part fully applies to the facilities required outside of the *sole-occupancy units* in Class 2.

#### ND1.3 Exit Travel Distances

The distances prescribed under the various sub-clauses for the two different Classes of building take into account the expected behaviour pattern of occupants. In addition in the case of Class 2 buildings there is every likelihood of the need to evacuate on receipt of a warning while sleeping. In the case of *health-care buildings* there is the likelihood of sedated and incapacitated patients having to be evacuated.

The maximum distances specified will ensure that in the case of buildings of very large *floor area* there will be a sufficient number of *exits* available in an emergency.

#### ND1.4 Distance Between Alternative Exits

The chances of the occupants of a building escaping from within a building safely and in the shortest practicable time will be when all the *required exits* are spaced uniformly. In terms of other considerations this may not always be possible or desirable. In such cases there is a need to ensure that any two alternate *exits* are not too close to each other. If they are very close it is quite possible that a fire could block both *exits* at the same time. The Code therefore prescribes that these *exits* should not be closer than 9 m apart. Spacing alternate *exits* too far apart will also defeat their purpose. Also in the case of occupants who are likely to be asleep or under medical care the maximum distance between alternate *exits* must be shorter than in any other case. This requirement has also been included in this clause.

#### ND1.5 Dimensions of Exits

This clause spells out reasonable practical ways of complying with clause NDP2.1 of the Performance Requirements of this Section. Whereas the Performance Requirements are based on experimental analysis the provisions in ND1.5 are based on empirical practice.

#### ND1.6 External Stairways

When external stairways are used as *required exits* there is a necessity to ensure that escape from the building through the stairway is safe. This clause ensures that vulnerable sections of the *exit* are suitably protected. This is illustrated in Sketch ND1.6.

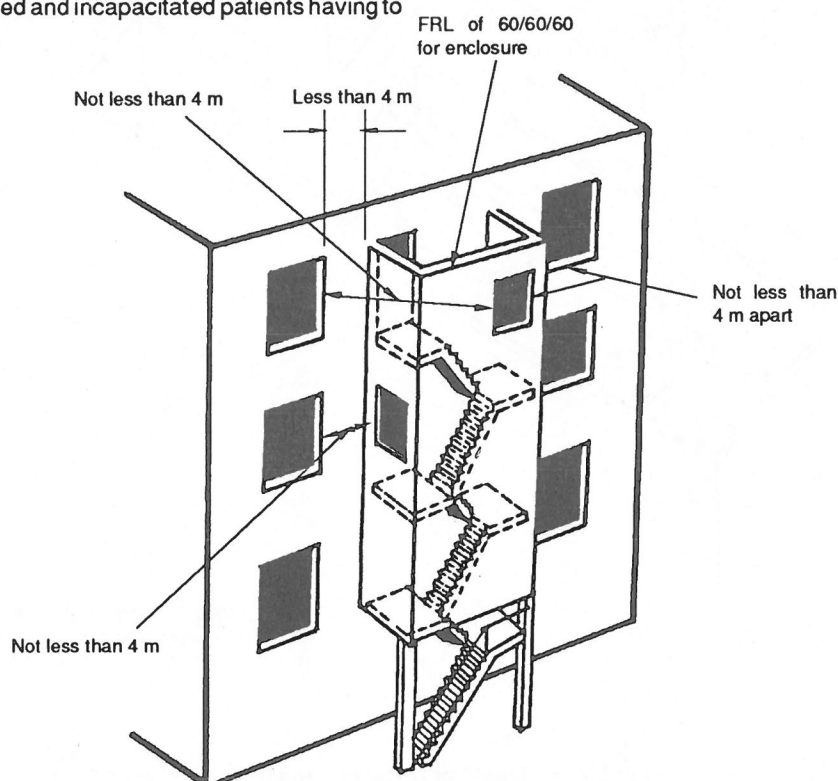

Sketch ND1.8 Requirements for External Stairways

### ND1.7 Travel by Stairways or Ramps

This clause details the requirements and restrictions for the use of stairways and ramps provided as *required exits*.

### ND1.8 Discharge from Exits

These requirements ensure that once the occupants of a building have safely walked along an *exit* they will face no obstruction or risk from fire and smoke when entering a road or *open space*.

### ND1.9 Horizontal Exits

*Horizontal exits* do not provide egress from a fire/smoke affected building. They only allow a quick means to escape from a fire/smoke affected part of a building to a safer part. This is why restrictions are placed on the circumstances under which *horizontal exits* can be recognised as *required exits*. The last sub-clause *requires* sufficient area on either side of a *fire wall* with a *horizontal exit* in it so that it will be possible to accommodate all the bed-ridden patients from both sides on either side of the *fire wall* in the case of a *health-care building*.

### ND1.10 Number of Persons Accommodated

The accompanying Table in the Code gives the basis for calculating the number of persons for whose emergency evacuation *exits* have to be designed. Where it is possible to assess the number of occupants on a factual or more rational basis the Table should not be used for the assessment. Incidentally the Table is not meant for the design of the *floor areas* of buildings.

### ND1.11 Measurement of Distances

In order to measure the distances mentioned in clauses ND1.3, ND1.4, and ND1.7 without confusion this clause states the meaning of the term "nearest part of an *exit*". This term is used in clause ND1.12.

### ND1.12 Method of Measurement

This clause specifies the routes along which the *exit* travel distances have to be measured. The attached sketches illustrate the method of measurement.

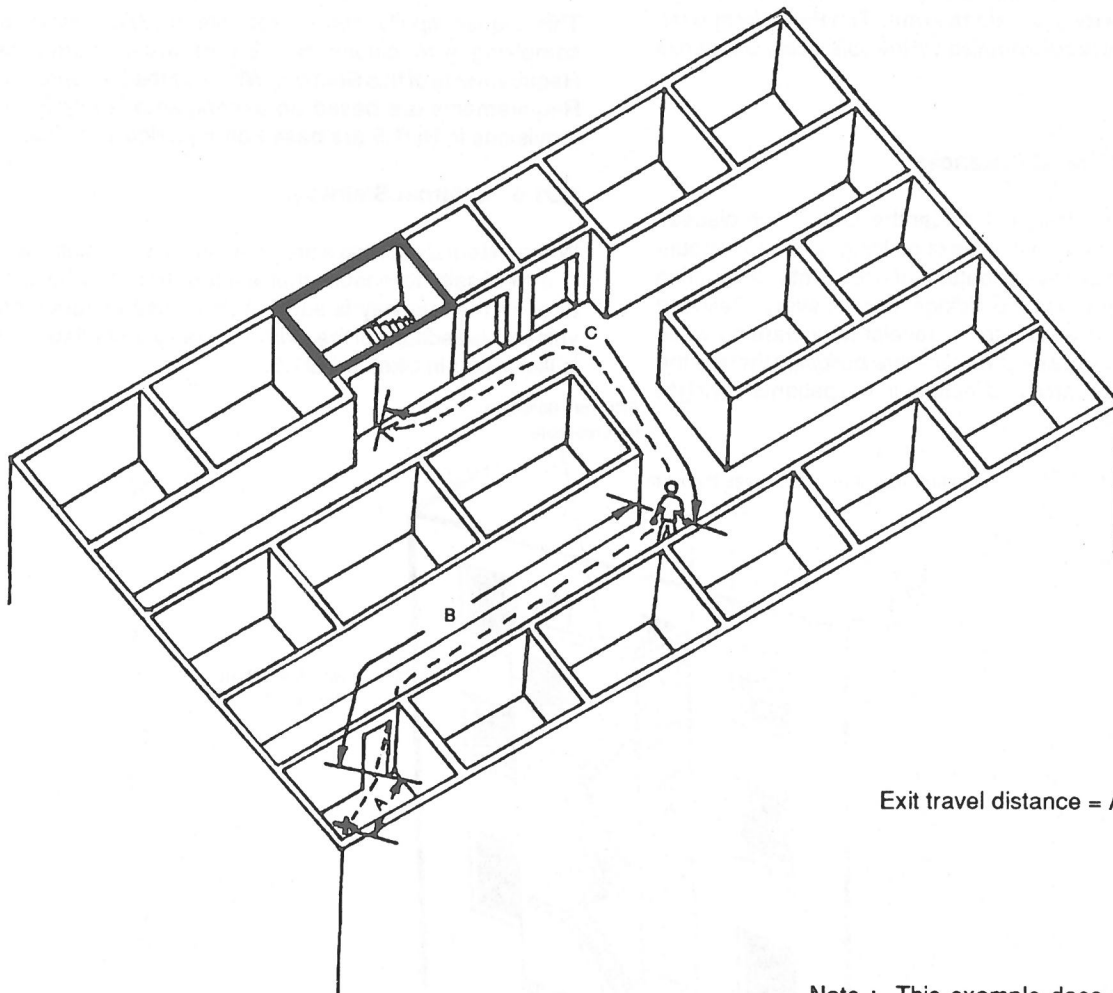

Exit travel distance = A + B + C

Note : This example does not apply to sole-occupancy units in Class 2

Sketch ND1.12 (i) Example of the Measurement of Distance From Any Point on a Floor to a Single Exit



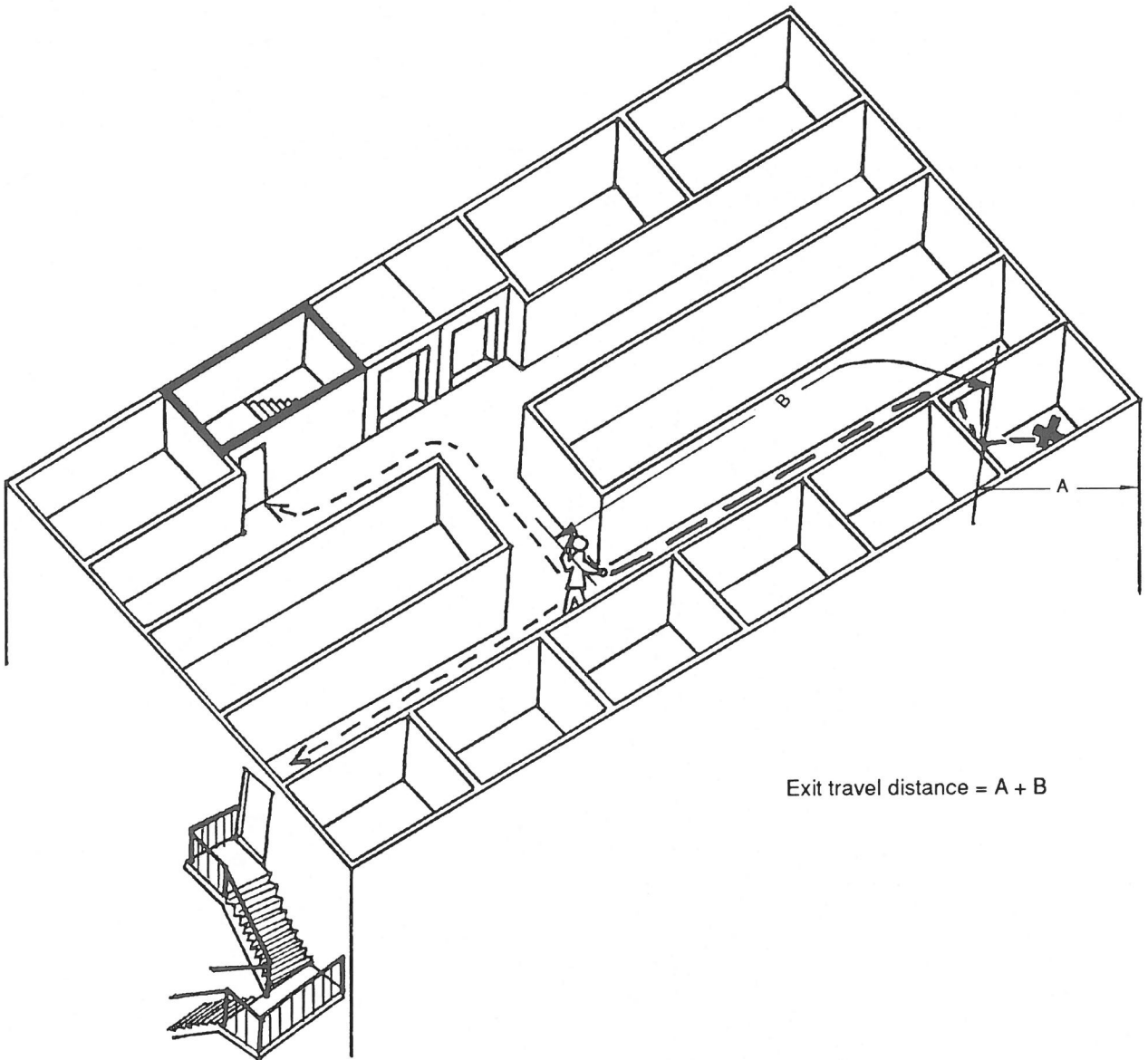

Exit travel distance = A + B

Note : This example does not apply to sole-occupancy units in Class 2

Sketch ND1.12 (ii) Example of the Measurement of Distance From Any Point on a Floor to the Point From Which Travel in Different Directions to Two Required Exits is Available

## **PART ND2 CONSTRUCTION OF EXITS**

### **ND2.1 Application of Part**

The requirements of this part do not apply to Class 2 except for clauses ND2.6 and ND2.9.

### **ND2.2 Stairways and Ramps**

This clause provides precautions to prevent the outbreak of fire in stairways and ramps. Apart from making them unsafe in the evacuation of the occupants, a fire in a stairway or ramp can very quickly spread to floors where any doorway leading to the *exit* has been left inadvertently open.

### **ND2.3 Installations in Exits and Paths of Travel**

### **ND2.4 Width of Stairways**

These 2 clauses aim to ensure that the *exit* is kept free of any risk of occurrence of fire within it and is free of obstructions for the rapid evacuation of occupants in an emergency. The reasoning behind sub-clause ND2.4(b) is that users of the stairway feel more safe in walking close to handrails. Therefore a very wide stairway without intermediate balustrades or handrails will generally not be useful over its full width.

## APPENDIX

While preparing the commentary a few mistakes were noticed in the Code. The corrections pertaining to these mistakes are given below. It will be appropriate to issue these formally when bringing the Code into use after the passing of the enabling legislation.

### INTRODUCTION

In the middle paragraph under the sub-heading "Layout of the Code", the reference to "and 10" should be deleted.

### PART A1 Clause A1.1 Definitions

**Automatic** The second line of this definition is not relevant. It should be deleted except for the last word "or".

**Effective Height** The reference to a "lift" in the third line of the definition should be deleted.

**Non-combustible** The inclusion of perforated gypsum lath with normal paper finish at (b) (ii) is not appropriate. Please delete this item and renumber the items from (i) to (iv).

**Open Space** The words "complying with ND2.12" should be deleted from the second line.

**Site** The definition as given can lead to disputes. It needs to also include the land in the vicinity of the building in order to erect it, make continued use of it and eventually to demolish it. Therefore a more appropriate definition would be as follows :

"The part of the allotment of land *required* for the erection, continued use, any alteration or addition, and demolition of a building."

### SEPARATORS FOR ALL SECTIONS BEGINNING WITH SECTION DC

For Sections DC to DG the reference to "AND 10" should be deleted. For Sections NC to NG the reference to "Class 2 to 9" should read "Class 2 and 3".

### PART NC3 Clause 3.8

The reference in the heading to "and 3" and in the sub-clause (a) to "or 3" should be deleted.

### SPECIFICATION NC1.1 Para 2.1 (a) (i)

The "not" after "a FRL of" should be deleted.

### PART NE PERFORMANCE REQUIREMENTS Clause NEP1.1

The words "fire compartments" at item (c) should be in italics.

The words "for automatic operation" in the second line under sub-heading "**Fire and Smoke Alarms**" should be deleted.





